

50, 75, & 150 PILOT

Repair Manual



KIMRAY
INC.®

INDEX

Introduction 1

Elastomer Materials 2

Disassembly 3

Part Inspection 6

Assembly 7

Testing 11

NOTE: We reserve the right to modify or change, without prior notice, any statement or information contained herein. If exact dimensions or specifications are required by the customer certified prints will be furnished for a minimum charge upon request to KIMRAY, Inc.
© Copyright 2006, KIMRAY, Inc.



SCOPE

This repair manual contains information for the 50 PG, 75 PG, and 150 PG pilot. Included is detailed instructions in regard to its repair.

DESCRIPTION

The 50 PG, 75 PG, and 150 PG pilot are designed for high pressure gas control. They are used in conjunction with a motor valve requiring a pneumatic signal. These pilots use a high pressure bellows to control a 3 Way valve or pilot plug. The action of the pilot may be changed from Indirect to Direct by inverting the SUPPLY HOUSING and the DIAPHRAGM ASSEMBLY. One adjustment screw is all that is required to set pilot. These pilots use 30 PSIG supply pressure and work in the control range of 1 PSIG change in sense pressure results in a change in the modulated output pressure of 1 PSIG. One turn of the adjusting screw will result in approximately 40 PSIG change in set point.

MAINTENANCE

Maintenance should be performed on a regular basis. An initial interval of 12 months is recommended. Depending on the service conditions and the condition of the controller, the inspection interval may be decreased or increased. The pilot can be repaired without removing the controller from the vessel, but the controller will need to be removed for any float related repair.

WARNING

Before performing any service, make sure level controller is isolated from all gas sources. Be sure that all operating or instrument gas lines have been disconnected. Never tighten any fittings or the main connections to the level controller while there is pressure in the lines.

GENERAL SPECIFICATIONS

Working Pressure	50 psig – 1500 psig
Material Options	316 SS6 12L-14 / Nickel Plated
Elastomers	Nitrile

To get the long service you have come to expect from Kimray products, always use **GENUINE KIMRAY PARTS** when doing repairs. Remember, parts made to less than Kimray specifications don't save you money!!!

ELASTOMER MATERIALS**AFLAS® is a trade mark of Asahi Glass Co****TEMPERATURE:**

-25° to +500° F
-30° to +260° C

APPLICATION:

Crude Oil & Gas Production (High heat), Steam Flood Production Chemicals (corrosion inhibitors) Amine Sweetener Systems, Gasoline, Diesel, Fuel Oil Systems

FLUID / GAS:

Crude Oil & Gas Production, H₂S, Steam, Petroleum fluids, Sea Water

HSN (Highly Saturated Nitrile)**TEMPERATURE:**

-15° to +300° F
-26° to +149° C

APPLICATION:

Crude Oil & Gas Production w/ H₂S CO₂

FLUID / GAS:

Crude Oil & Gas H₂S, CO₂, Sea Water

NITRILE**TEMPERATURE:**

Buna-N:
-40° to +220° F
-40° to +105° C
Low-Temp:
-85° to +120° F
-65° to +49° C

APPLICATION:

Crude Oil & Gas Production Glycol Dehydrators, Gasoline, Jet Fuel & Diesel Fuel Pumping, Water Disposal, Methanol Injection Pumps, Water pump seals, hydraulic pump seals

FLUID / GAS:

Crude Oil & Gas, Good to Poor in Sour Production (See HSN), Water, Glycols, Hydraulic Oils, Resistance to crude oil in the presence of hydrogen sulfide and amines, Diesel fuel, fuel oils

DO NOT USE WITH:

Aromatic hydrocarbons, chlorinated hydrocarbons, phosphate esters (hydraulic fluids)

GYLON**TEMPERATURE:**

-350° to +500° F

APPLICATION:

High heat, high chemical resistance, highly resistance to gas permeation

VITON® is a trade mark of Dupont**TEMPERATURE:**

-10° to +350° F
-23° to +177° C

APPLICATION:

Crude Oil & Gas Production, Glycol Dehydrators, Gasoline, Jet Fuel & Diesel Fuel Pumping, Water Disposal, Methanol Injection Pumps. (Also Vacuum Service) (Gas permeability is very low)

FLUID / GAS:

Crude Oil & Gas, Sour Gas (CO₂), Propane, Gasoline, Diesel, Fuel Oil Systems

DO NOT USE WITH:

Hot Water, Not preferred for wet H₂S, Methyl Alcohol, Amines, Sodium hydroxide solutions

ETHYLENE PROPYLENE**TEMPERATURE:**

-65° to +300° F
-54° to +148° C

APPLICATION:

Steam Flood

FLUID / GAS:

Steam, Water, Alcohol

DO NOT USE WITH:

Crude Oil & Gas, Diester Lubricants (Lube Oils)

POLYURETHANE**TEMPERATURE:**

-40° to +220° F
-40° to +104° C

APPLICATION:

High abrasion resistance Seats, Diaphragms

FLUID / GAS:

Crude Oil gas and Water, Sour Gas (CO₂), propane, butane, fuel, mineral oil and grease

POLYACRYLATE**TEMPERATURE:**

±0° to +300° F
-17° to +149° C

APPLICATION:

Production Heaters, Thermostats

FLUID / GAS:

Crude Oil & Gas at High Temperature

DO NOT USE WITH:

Alcohol, Glycols

STEP 1**REMOVE ADJUSTMENT SCREW**

Remove any connection from body. With 9/16 wrench remove adjustment screw. (Fig 1.1 & Fig 1.2).



Figure 1.1



Figure 1.2

STEP 2**REMOVE LOWER HOUSING**

Flip pilot upside down and secure, then remove 4 bolts holding body to bonnet. Remove any plugs from housing at this time (Fig 2.1). Remove lower housing and set aside at this time. (Fig 2.2).



Figure 2.1



Figure 2.2

STEP 3**REMOVE MIDDLE HOUSING**

Remove middle housing and place on bench. (Fig 3.1). With adjustable wrench remove diaphragm nut (Fig 3.2).



Figure 3.1



Figure 3.2

Remove diaphragm spacer (Fig 3.3).



Figure 3.3

Remove diaphragm plate (Fig 3.4), it may be stuck in place. Use caution when removing so not to score housing or plate if a screwdriver is used. (Fig 3.5).



Figure 3.4



Figure 3.5

DISASSEMBLY

With flat blade screw driver peel up diaphragm and remove stem from housing.
Discard diaphragm it will be replaced.
(Fig 3.6).



Figure 3.6

Figure 3.7

Flip middle housing over and remove diaphragm nut (Fig 3.8). Remove diaphragm spacer (Fig 3.9).



Figure 3.8

Figure 3.9

Remove upper diaphragm and seat from body and discard diaphragm (Fig 3.10). Remove upper seat from seat housing and discard seat (Fig 3.11).



Figure 3.10

Figure 3.11

Remove lower seat and pilot plug and discard (Fig 3.12). Remove spring from under lower seat and discard (Fig 3.13).



Figure 3.12

Figure 3.13

**STEP 4
REMOVE BONNET**

Remove lower spring plate (Fig 4.1).
Remove spring (Fig 4.2).



Figure 4.1

Figure 4.2

Remove upper spring plate (Fig 4.3)



Figure 4.3

**STEP 5
REMOVE LOWER HOUSING**

Remove breather plug and make sure it is clear of any obstructions. (Figure 5.1 & 5.2)



Figure 5.1



Figure 5.2

Remove lower housing from main body. Being careful not to damage the bellows. (Fig 5.3). Remove O-Ring from lower housing and discard (Fig 5.4).



Figure 5.3



Figure 5.4

Carefully not to crush bellows remove it from lower housing, channel locks may be used if it is stuck (Fig 5.5). Discard O-Ring from top of bellows. Make sure to save the washer under o-ring (Fig 5.6). Make sure bellows does not have any holes and fins have not flattened.



Figure 5.5



Figure 5.6

Washer present on 150 PG Pilot but not on 50 or 75 PG

WASH ALL PARTS BEFORE ASSEMBLY

PART INSPECTION

STEP 1
BELLOWS

Look for cracks in bellows or separation in rings. This can be caused by pulsation or over pressure. (Fig 1.1)



Figure 1.1

Look for cracks or splits in diaphragm. (Fig 1.2)



Figure 1.2

Port from supply input to lower seat must be cleaned and blown out well. This port is easy to overlook and can become blocked. Even the smallest particle of rust or dirt can clog pilot plug causing failure to occur. (Fig 1.3 & F 1.4)



Figure 1.3

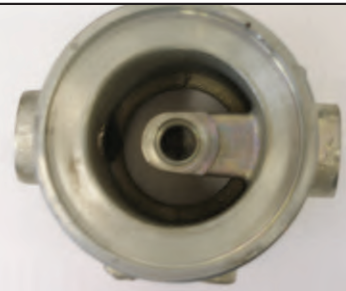

Figure 1.4

STEP 1 ASSEMBLE MIDDLE HOUSING

INDIRECT

Open kit # RBQ and check for all parts. (Fig 1.1).



Figure 1.1



NOTE:

Always check fastener tightness prior to valve installation, testing, and use, as fasteners have the potential to loosen in transit. This is recommended to ensure your safety and proper valve function.

Kimray assembly torque method below

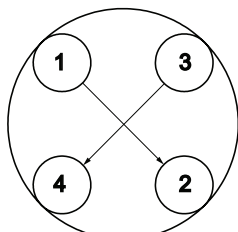

Four Bolt

If **DIRECT** pilot simply turn middle housing upside down (Fig 1.2)

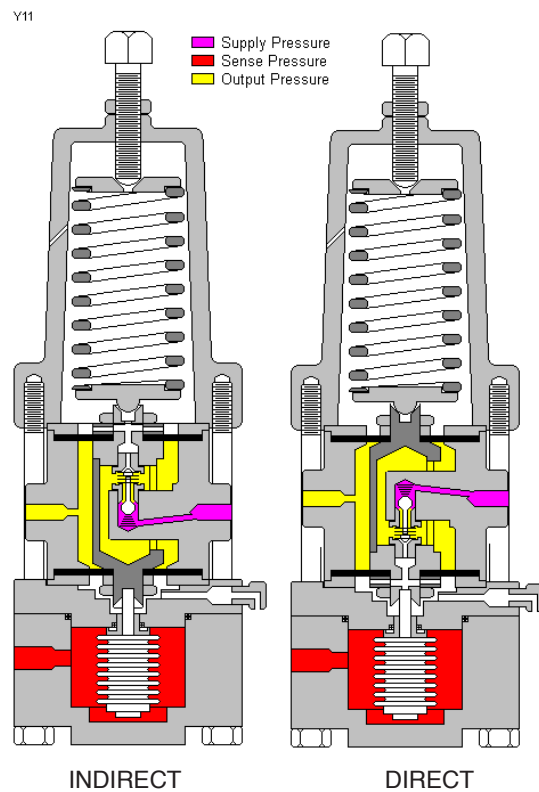

Figure 1.2

Install #108 spring, make sure supply port is clear of any obstructions and clean. (Fig 1.3). Insert O-Ring over #111 seat by rolling so as not to cut O-Ring and insert pilot plug small ball first (Fig 1.4).



Figure 1.3



Figure 1.4

ASSEMBLY

Install lower seat into housing and tighten snug (Fig 1.5). Install O-Ring on upper seat #113 again rolling over threads so as not to cut (Fig 1.6).



Figure 1.5

Figure 1.6

Install #113 seat into seat housing and tighten snug (Fig 1.7). Now install diaphragm #4436 (Fig 1.8).



Figure 1.7

Figure 1.8

Install diaphragm spacer #4442 and align holes in spacer with holes in housing to make a through hole (Fig 1.9). Screw on diaphragm nut to secure, making sure holes are still aligned (Fig 1.10).



Figure 1.9

Figure 1.10

Place upper seat housing over small ball of pilot plug make sure it is aligned (Fig 1.11). Place ring on top of diaphragm as shown plate #4441 (Fig 1.12).



Figure 1.11

Figure 1.12

Place diaphragm #4447 over stem (Fig 1.13). Place spacer ring after diaphragm (Fig 1.14).



Figure 1.13

Figure 1.14

Tighten nut snug to secure (Fig 1.15).



Figure 1.15

STEP 2

ASSEMBLE LOWER HOUSING

Install washer on bellows ONLY ON 150 PG PILOT (Fig 2.1). Roll O-Ring over threads to install (Fig 2.2)



Figure 2.1

Figure 2.2

Screw bellows into lower housing snug (Fig 2.3). Install O-Ring around lower housing (Fig 2.4).



Figure 2.3

Figure 2.4

Place bellows assembly into lower housing (Fig 2.5).



Figure 2.5

STEP 8

ASSEMBLE MIDDLE HOUSING

Place stem assembly into middle housing. On direct pilot this diaphragm goes up towards spring if indirect pilot this diaphragm faces towards bellows (Fig 3.1).



Figure 3.1

ASSEMBLY

Place diaphragm plate # 4434 over diaphragm (Fig 3.2). Diaphragm plate #4434 center hole is 1.37" make sure you do not put diaphragm plate #4441 on this end.



Figure .3.2

Place lower spring plate on top of stem apply grease where they connect (Fig 3.3). Place upper spring plate on spring (Fig 3.4).

Grease



Figure 3.3

Figure 3.4

Place upper bonnet over spring (Fig 3.5). Flip unit over and install mounting plate and 4 screws and tighten (Fig 3.6).



Figure 3.5

Figure 3.6

Align sense holes on bottom with supply and output holes in middle housing. Breather hole needs to be rotated 90 deg from supply and output ports holes (Fig 3.7).



Figure 3.7

Install adjustment screw and apply grease to end before inserting (Fig 3.8). Install breather plug with loc-tite (Fig 3.9).

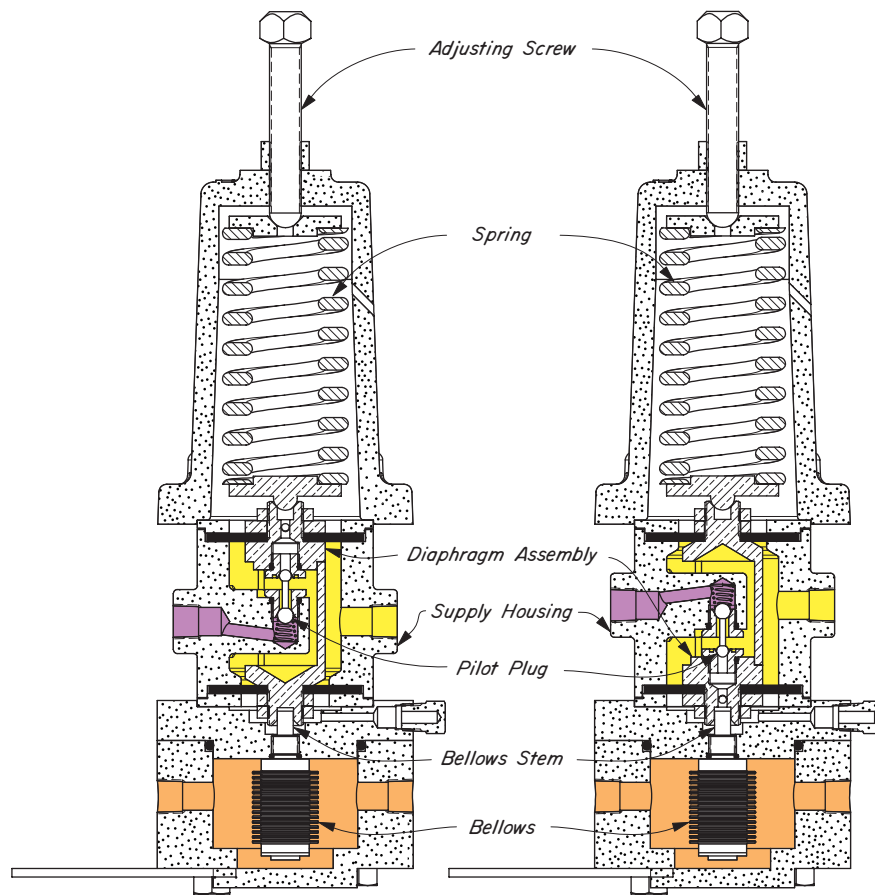

Figure 3.8

Figure 3.9

With 20 psi supply connected and minimum sense pressure connected for 50, 75, or 150 PG. Start with adjustment screw all the way out and tighten until output comes on for Indirect Acting.

For Direct Acting connect same as above and turn adjustment screw until output turns off.



- Supply Pressure, 20 psi required.
- Output Pressure, Can install gauge here when testing to measure output.
- Sense Pressure, On 50PG & 75PG a minimum of 75 psi required.
On 150PG a minimum of 125 psi required.



