

CAUTION

Prior to installing, the instructions provided herein should be completely reviewed and understood before operating or repairing this equipment. All CAUTION and WARNING notes must be strictly observed to prevent personal injury or equipment damage.

Description

The Kimray gas pilot - operated pressure regulator combines a pressure pilot with a control valve. Except where liquid or very low gas pressure is involved, upstream gas is used to operate the valve.

Regulators perform one of three functions: the back pressure regulator maintains a constant upstream pressure: the pressure reducing regulator maintains a constant downstream pressure and the differential pressure regulator maintains a constant difference between upstream and downstream pressure.

A name tag is attached to each valve. The name tag lists the serial number, model number, and pressure rating.

Installation

Before installing the pressure regulator, inspect it for shipment damage and for foreign material that may have collected during shipment. Inspect the openings in the valve and clean the pipe lines to remove scale, chips and debris. For flanged bodies, remove the masking sticker from the raised face of each end connection.

1. Install the regulator with the arrow on the body pointing in the direction of flow. The arrow indicates the direction of flow and will not necessarily prevent flow in the opposite direction.
2. Install the regulator using good piping practice. For flanged bodies use a suitable gasket between the body and the pipeline flanges. For threaded (NPT) bodies, use TFE tape or pipe thread sealant on external pipe threads.
3. Verify all pressure connections are tight before pressurizing the system.
4. Back Pressure Regulator & Differential Regulator: Remove the stopper after the regulator is installed. The plug prevents the oil from leaking out of the regulator during shipment and installation. See figure 1.

5. Pressure Reducing Regulator: Because your regulator contains oil, both the plastic and brass caps are used to prevent the oil from leaking out of the regulator during shipment and installation. A disconnected section of tubing is shipped along with the regulator. Some minor assembly will be required after the regulator is placed in line and prior to start-up.
 - Remove the two safety caps placed on the tubing fittings. The cap on the upper fitting is blue plastic; the cap on the lower fitting is brass. Save the cap in the event the regulator needs to be removed from service for repairs. See figure 2.
 - Install the section of tubing and wrench tighten the fittings only after the regulator has been installed in the piping.

CAUTION

When ordered, the regulator and construction materials were selected to meet specific pressure, temperature, pressure drop and fluid conditions. Since some body/trim material combinations are limited in their pressure drop and temperature ranges, do not subject the regulator to any other conditions without first contacting the Kimray Inc, sales office or a sales / applications representative.

Note

 All regulators are tested after they are assembled at Kimray, but they are not pre-set to a specific setpoint. The best practice for obtaining a specific setpoint is to do so upon installation in the desired application.

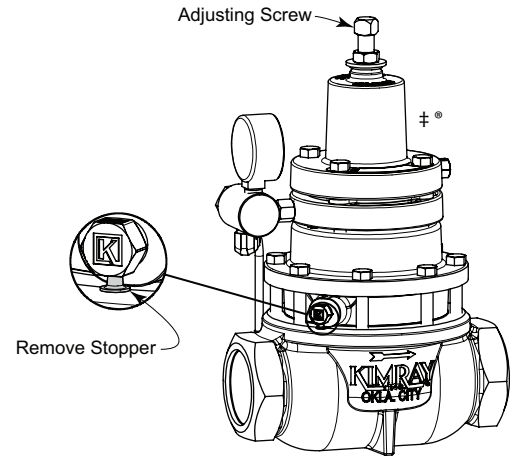

Figure 1

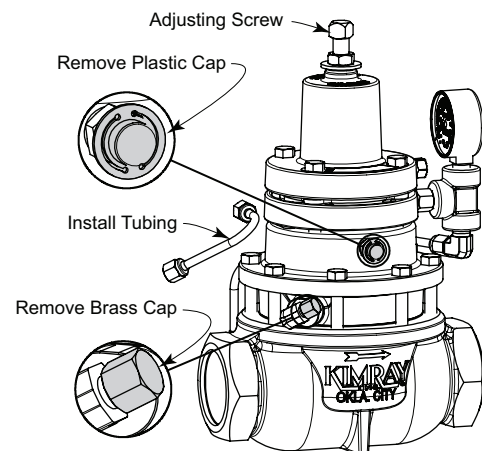



Figure 2

Note

 Install the regulator in a horizontal line. Only install a pilot - operated regulator up to a 3 inch in a vertical line.

Start-up and Test

With the installation completed and appropriate relief and check valves installed and set, slowly open the upstream and downstream shutoff valves. Turn the adjusting screw out and then back in until you feel it begin to meet resistance as it engages the spring. At this point the valve section on the regulator will be positioned as follows:

- Back Pressure Regulator Open
- Pressure Reducing Regulator Closed
- Differential Pressure Regulator Open

As you turn the adjusting screw clockwise, the set point pressure will increase.

Maintenance

Maintenance should be performed on a regular basis. An initial inspection interval of 6 months is recommended. Depending on the service conditions of the valve, the inspection interval may be decreased or increased.

The valve can be repaired without the body being removed from the piping.

Only use genuine Kimray replacement parts.

Repair kits and detailed repair instructions are available for each valve.

Visit www.kimray.com or contact your Kimray authorized distributor for additional product information and / or literature.

Inspection Schedule	
Valve Seat *	Inspect every 6 months under normal service and conditions. Under severe service conditions such as sand, corrosion, salt, or high pressure drop, inspect regularly until a predictable pattern can be established.
Seals	Should be replaced as needed. Check for cracks, swelling or if the seals feel hard, replace.
Body	Under normal conditions, the body will last for years. Severe conditions will require inspection more frequently.
Pressure Pilot	Inspect spring, stem, and diaphragms once a year.
Seats	Inspect once a year with Pressure Pilot.
* Under severe operating conditions this maintenance schedule will not be adequate and a shorter time schedule may be required.	

Trouble Shooting		
Problem	Possible Cause(s)	Possible Solution
Regulator appears to be stuck in on position.	Stopper has not been removed from breather plug in lower housing. (BP Regulator)	Remove the stopper.
Regulator leaks through to downstream.	Over tightened seat nut can cause seat to bulge and leak.	DO NOT OVER TIGHTEN seat.
Pilot bleeds gas continuously.	The pilot plug seat may be dirty.	Clean the pilot plug seat.
Minimum set point cannot be set.	Wrong spring.	Install correct Spring.
Regulator will not open.	A pilot seat may be loose. (BP Regulator)	Tighten the pilot seat.
Regulator will not close.	A pilot seat may be loose. (PR Regulator)	Tighten the pilot seat.

WARNING

Before beginning installation:

- Read and follow instructions.
- Make sure the valve cannot operate during installation.

Do not exceed the maximum supply pressure specified on the valve name-plate.

Never tighten any fitting or the main connections to the valve while there is pressure on the line.

WARNING

Before any service, be certain that the valve is fully isolated and that all pressure upstream and downstream has been relieved. Use bypass valves or fully shut off the process.

Be sure that any operating or instrument gas lines have been disconnected.

Never stand directly in front of or over a valve when the system is pressurized. The valve could suddenly open, blowing debris into the person's face and eyes.

WARNING

A leaking valve is an indication that service is required. Failure to take valve out of service immediately may cause a hazardous condition.

NOTE

If conditions indicate the possibility of backward flow you may wish to install check valves. Never assume that a check valve is fully blocking the downstream line.

For questions or comments, contact your local Kimray authorized distributor, or visit www.kimray.com.

Kimray Inc.
52 NW 42nd Street
Oklahoma City, OK 73118

Customer Service: 405.525.6601 | service@kimray.com

Product Support: 405.525.4264 | ProductSupport@Kimray.com

All Pictures shown are for illustration purpose only. Actual product may vary due to product enhancement.
‡ Configuration of the Back Pressure Valve is a trademark of Kimray, Inc.

www.kimray.com