

INTRODUCTION:

The Glycol Energy Exchange Pump, "Pressure Volume" or "PV-Series" Pump was developed in 1957. The initial consideration was a pump that would utilize the energy of the wet glycol at absorber pressure as a source of power. Within the confines of a system, energy can neither be created nor destroyed. Energy can, however, be stored, transferred, or changed from one form to another. The PV Series Pump transfers the energy available from the wet glycol, at absorber pressure, to an "equivalent" volume of dry glycol at reboiler pressure. In order to circulate the glycol, additional energy is needed to overcome friction losses within the pump and connecting piping.

This additional energy is supplied by gas at absorber pressure.

The pump was designed as double acting with a maximum working pressure of 2000 psig with a factor of safety of ten. Corrosion and wear dictated use of the best materials available. These materials include stainless steel, hard chrome plating, nylon, Teflon, stellite, and "O"-rings specially compounded for glycol service. The pump contains two basic moving parts, a Piston-Rod Assembly, and a Pilot Piston. Each actuates a three-way D-slide.

Kimray is an ISO 9001- certified manufacturer.

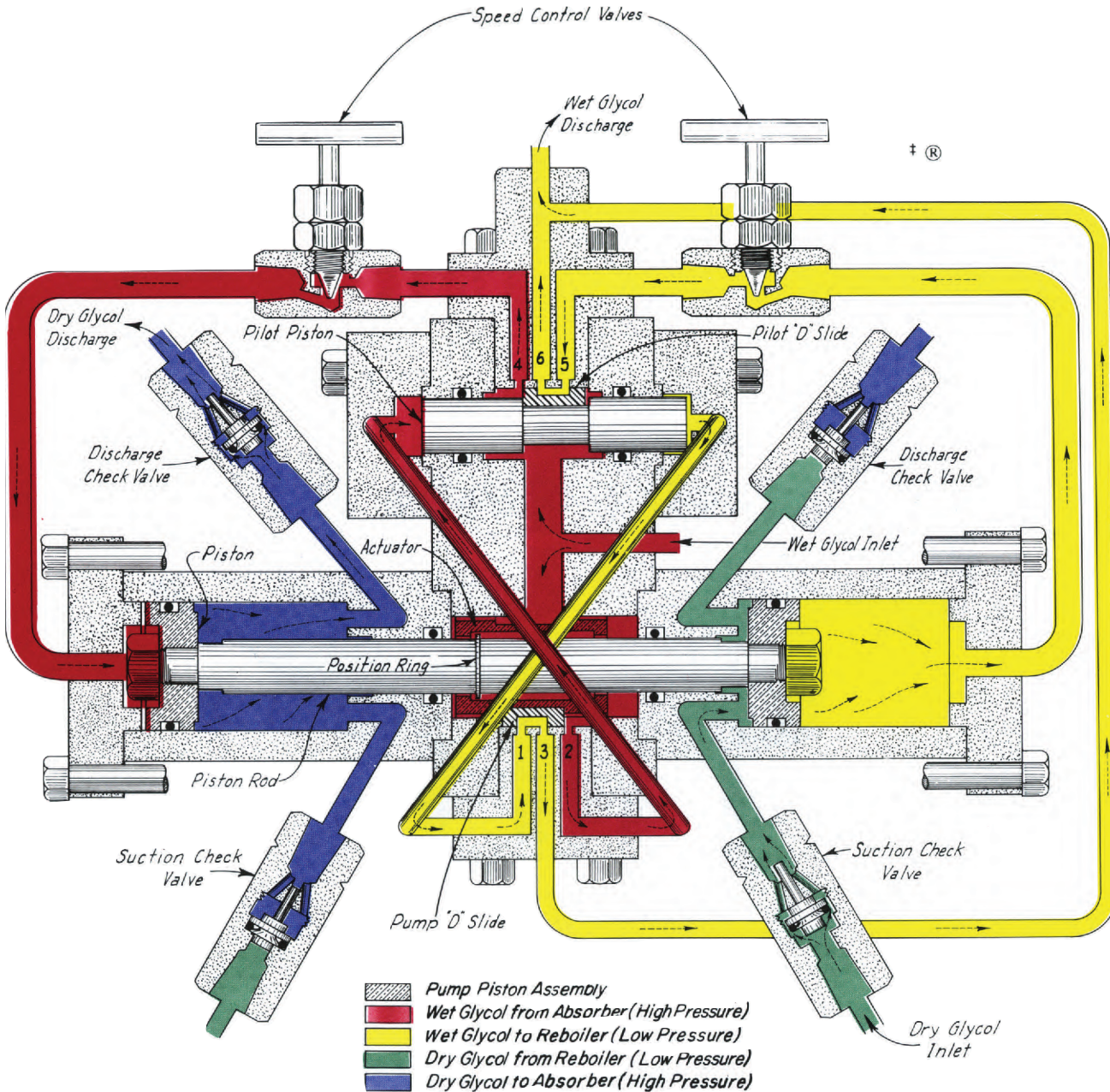

OPERATION:

The Kimray glycol pump is double acting, powered by Wet Glycol and a small quantity of gas at absorber pressure (Red). (Yellow) denotes Wet Glycol and gas at atmosphere or low pressure. Dry Glycol (Blue) is being pumped to the absorber. (Green) is Dry Glycol suction from the reboiler.

Wet Glycol (Red) from the absorber flows through port #4 and is throttled through the SPEED CONTROL VALVE to the left end of the Pump Piston Assembly, moving this assembly from left to right. Dry Glycol (Blue) is being pumped from the left cylinder to the absorber while the right cylinder is being filled with Dry Glycol (Green) from the reboiler. At the same time Wet Glycol (Yellow) is discharging from the right end of the Pump Piston Assembly to a atmosphere or low pressure system.

As the Pump Piston Assembly nears the end of its stroke, the POSITION RING on the PISTON ROD contacts the right end of the ACTUATOR. Further movement

to the right moves the ACTUATOR and PUMP "D" SLIDE to uncover port #1 and communicate ports #2 and #3. This exhausts Wet Glycol (Red) to the right end of the PILOT PISTON. This causes the PILOT PISTON and PILOT "D" SLIDE to be driven from right to left.

In its new position the PILOT "D" SLIDE uncovers port #5 and communicates ports #4 and #6. This exhausts Wet Glycol (Red) from the left end of the Pump Piston Assembly through ports #4 and #6 to the low pressure Wet Glycol (Yellow) system. Port #5 (which was communicated with port #6) now admits Wet Glycol (Red) through the right hand SPEED CONTROL VALVE to the right end of the Pump Piston Assembly.

The Pump Piston Assembly now starts the stroke from right to left. Follow above procedure reversing directions of flow..

Kimray is an ISO 9001- certified manufacturer.

PRINCIPLE OF OPERATION:

Actions of each of the two basic parts of the pump are completely dependent upon the other. The pilot D-slide actuated by the Pilot Piston alternately feeds and exhausts absorber pressure to the power cylinders at opposite ends of the Piston-Rod Assembly. Likewise, the Pump D-slide actuated by the Piston-Rod Assembly alternately feeds and exhausts absorber pressure to opposite ends of the Pilot Piston.

The force to circulate glycol within the dehydration system is supplied by absorber pressure acting on the area of the Piston Rod at its O-ring seals. The area of the Piston Rod is approximately 20 percent of that of the Piston. Neglecting pump friction and line losses, the resultant force is sufficient to produce a theoretical discharge pressure 25 percent greater than absorber pressure. The theoretical discharge pressure, for example, at 1500 psig absorber pressure would be 1875 psig. This theoretical "over-pressure" would develop against a blocked discharge line but is not sufficient to cause damage or create a hazard.

Approximately 25 to 30 psig pressure is required to overcome pump friction leaving the additional "over pressure" for line losses and circulation. It is recommended that these losses be held to approximately 10 percent of the absorber pressure or as noted in catalog.

Two Speed Control Valves are provided to regulate the flow of wet glycol and gas to and from the power cylinders. Reversing the direction of flow through the Speed Control Valves provides a flushing action which cleans the valve orifices.

If the wet glycol, returning to the pump from the absorber were to be completely fill the cylinder, no additional gas would be needed. However, the wet glycol will only occupy approximately 65 percent of the total volume of the cylinder and connecting tubing leaving 35 percent to be filled by gas from the absorber. This gas volume amounts to 1.7S.C.F. per gallon of dry glycol at 300 psig absorber pressure and 8.3S.C.F. at 1500 psig and may be considered as continuing power cost for pump operation. This gas can be utilized in the regeneration process of the dehydrator for "rolling" and or "stripping" purposes. It may also be recovered in a low pressure glycol gas separator and used to fire the reboiler pressure glycol gas separator and used to fire the reboiler.

By supplying some absorber gas to the cylinders, the wet glycol level is maintained at the wet glycol outlet connection on the absorber and eliminates the need of a liquid level controller and its attendant problems. Excess liquids such as hydrocarbons are removed from the absorber at approximately 55 percent of the pump rate, reducing the hazard of dumping a large volume of hydrocarbons into the reboiler as would be the case with a liquid level controller.

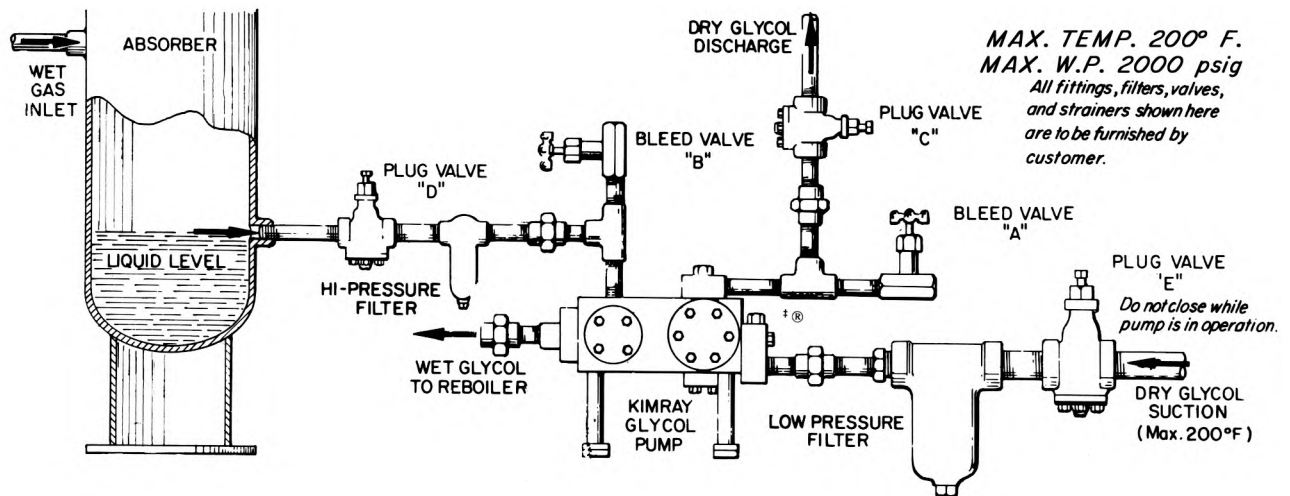

INSTALLATION:

A number of considerations should be made with regard to pump installation since it is the "heart" of a dehydration system. It is a moving mechanical device subject to wear and will ultimately need repair. Location of the pump is very important. Easy access to the pump for repair or exchange can save time and trouble.

Test connections (1/4" NPT with valve) located on the piping to and from the pump permit a fast means of trouble shooting pipe restrictions or blockage.

Filters, which are discussed later, should always be installed in the wet glycol piping between the absorber and pump and in the suction line to the pump, with provisions made for maintenance of the filters.

Suction piping should preferably be large enough to permit a positive feed to the pump. Feed pressure must be more than 4 or 5 inches of Hg vacuum to prevent pump cavitation.

Where two or more pumps are manifolded together, the total capacity must be considered in the piping design. Also, a manifold should be designed to provide each pump with its "Fairshare" of the wet glycol from the absorber. It is not necessary that the proportion be exact.

Pumps with lower "pumping ratios" are available to provide additional energy for pressures below 300 psig; but it is better not to use these pumps at pressures above 400 or 500 psig because of excess gas consumption. Conversion kits are available to change standard pumps to "SC" pumps with declining field pressures.

ENERGY EXCHANGE PUMPS

HEAT EXCHANGERS:

Sufficient heat exchange is necessary to reduce dry glycol suction temperature to at least 200°F, preferably to 150°F.

SPLIT DISCHARGE CHECK VALVE BLOCK:

Kimray Glycol Pumps are available with check valve blocks for split discharge to serve two absorbers on a dehydration unit. See page 10.29 for a description.

VITON "O" RINGS:

Viton "O" rings for all moving seals in the Kimray Glycol Pumps are available. Viton repair kits can be ordered for pumps already in operation or new pumps can be ordered with viton "O" rings at additional cost.

Viton "O" rings are recommended for use when liquid hydrocarbons are found in the gas, for CO₂ service or for elevated operating temperatures. Under normal conditions (without the above problems) viton "O" rings will not give as long of a service life in the pump as standard Buna-N "O" rings.

SYSTEM PRESSURE DROPS:

The Kimray Glycol Pumps are designed to operate by using the energy from the wet glycol and some additional energy in the form of gas at absorber pressure. Excessive pressure drops in the lines connecting the pump to the system can cause the pump to run erratically or stall. The following conditions should be designed into the system to assure proper pump performance:

DRY GLYCOL SUCTION LINE: Size the suction line, low pressure filter and heat exchanger such that the pump will have a positive pressure at the suction inlet when running at the maximum rated speed. This line may need to be larger than the pipe fitting on the suction check valve block. (See pipe connection sizes on page 10.28.)

WET GLYCOL POWER LINE: Recommended line size is the same as the size of the pipe connection for the given pump. (Page 10.28) The pressure drop across the high pressure filter is a factor in considering the total system pressure drop.

DRY GLYCOL DISCHARGE LINE: Recommended line size is the same as the size of the pipe connection for the given pump and the absorber should be full opening to the recommended line size.

WET GLYCOL DISCHARGE LINE: Recommended line size is the same as the size of the pipe connection for the given pump. (Page 10.28.) If a glycol gas separator is used, the pressure maintained on the separator must be considered in the total system pressure drop. Also, heat exchanger coils in accumulator tanks also add to this pressure drop.

ISOLATING VALVES: All plug, gate, or blocking valves should be full opening to the recommended line size of the given pump.

If a positive feed is supplied to the pump at the dry suction inlet, the total system pressure drop will be the sum of the following pressure drops:

1. The pressure drop between the absorber and the pump in the wet glycol line.

2. The pressure drop between the pump and the absorber in the dry glycol discharge line including any pressure required to open and establish full flow in any check valves.

3. The pressure drop between the pump and the reboiler (at atmospheric pressure) in the wet glycol discharge line. This includes the liquid head to the reboiler, heat exchanger coil, and/or the pressure maintained on a glycol separator.

The sum of these pressure drops gives the total "system pressure drop". The graphs on pages 10.11-10.15 give the maximum total system pressures and their effect on pump output. Exceeding the total allowable system pressure drop will cause the pump to run erratically or to stall.

To determine if a problem exists in an operating dehydration system, slowly open the speed control valves on the pump until it runs at the maximum recommended pump speed. (See graph page 10.8.) If the Pump cavitates before reaching the maximum pump speed, the suction line is restricted. If the pump will not run at the maximum rated speed, then there are probably restrictions in one or more of the other three connecting lines.

FILTERS:

Filters *should* be used on every dehydrator for protection of both the pump and reboiler. Many pumps are severely damaged in the first minutes or days of operation from flow line and vessel debris. Reboilers have been known to be filled with sand which had to first pass through the pump.

Filters should give protection from 25 to 150 micron particle sizes depending on the specific condition. The disc type, micron type, and sock type have all proven very satisfactory if they are properly maintained. Some metal filters are equipped with a cleaning device which should be operated daily or at least every few days as experience may dictate. Sock filters must be replaced at regular intervals. Preventative maintenance on these filters will save many dollars in major pump and reboiler repairs plus the reduction of costly down time.

A spring loaded by-pass on the filter is not recommended. It is better for the pump to stall due to lack of power than be exposed to dirt and grit from an open by-pass. Always install a high pressure filter between the absorber and the pump. A filter on the wet glycol discharge of the pump will protect the reboiler but does nothing for the pump. A low pressure filter on the pump suction protects against metallic particles from a new reboiler and its connecting piping. Filters will also keep the glycol free of heavy tars and residue from evaporated hydrocarbons and resinous compounds caused by polymerization of the glycol. Sock type filters are probably best for this type of filtration but should be changed rather frequently.

In addition to using filters it is often necessary to make a chemical analysis of the glycol, not only for pump protection but for better dehydration. Organic acids in glycol are produced from oxidation, thermal decomposition, and acid gases from the gas stream. These acids cause corrosion in the system, and dissolve the plating on pump parts in a short time. Glycol acidity should be maintained between a pH of 7 to 9. Alkaline amines are usually recommended to control the pH value because they will neutralize any acid gases present and are easily regenerated.

Another glycol contaminate which causes pump problems is salt. Salt water which continues to enter a dehydration system soon produces a super saturated condition in the reboiler. This results in salt deposits in the lines and in the pump as the hot glycol is cooled. A complete cleaning and washing of the entire system is required to remove the salt.

OPERATION:

A new pump or new dehydrator should be put into operation by first bringing the glycol circulation and operating temperature to an equilibrium condition by using 300 to 400 psig absorber pressure. This can be done with or without gas flow. If it is easier to start up under a no-flow condition, only enough gas need be supplied the absorber to maintain the pressure. In most instances the pump will pick up its prime without help and should do so in a few strokes. If the pump does not prime immediately, the dry glycol discharge should be opened to atmosphere until glycol discharges from both cylinders. When equilibrium has been established, the pump should be stopped and the absorber pressure increased for operation. Pump speed can then be reestablished to the desired rate.

The maximum operating temperature of the pump is limited by the moving "O"-ring seals. A maximum of 200 degrees is recommended. Packing life will be extended considerably at 150 degrees.

SYMPTOMS

1. The pump will not operate.
2. The pump will start and run until the glycol returns from the absorber. The pump then stops or slows appreciably and will not run at its rated speed.
3. The pump operates until the system temperature is normal then the pump speeds up and cavities.
4. The pump lopes or pumps on one side only.
5. Pump stops and leaks excessive gas from wet glycol discharge.
6. Erratic pump speed. Pump changes speed every few minutes.
7. Broken Pilot Piston.

Always stop the pump when the pump main gas flow is turned off. A pump which continues to circulate with no gas flow elevates the complete dehydrator temperature, and in time to reboiler temperature.

If a pump has been deactivated for several months, the check valves should be removed and inspected before attempting to operate the pump. The pump startup should be similar to that of a new pump by first bringing the system to equilibrium.

TROUBLE SHOOTING:

If a glycol pump has been operating in a clean system it is very likely that no major service will be required for several years. Only a yearly replacement of packing will be required. Normally the pump will not stop pumping unless some internal part has been bent, worn, or broken, or some foreign object has fouled the pump, or the system has lost its glycol.

A pump which has been running without glycol for some time should be checked before returning to normal service. Probably the pump will need at least new "O"-rings. The cylinders and piston rods may also have been scored from the "dry run"

Following are some typical symptoms and causes. These are presented to assist in an accurate diagnosis of trouble.

CAUSES

1. One or more of the flow lines to the pump are completely blocked or the system pressure is too low for standard pumps (below 300 psig) use "SC" pumps below 300 psig
2. The wet glycol discharge line to the reboiler is restricted. A pressure gauge installed on the line will show the restriction immediately.
3. The suction line is too small and increase in temperature and pumping rate cavities the pump.
4. A leaky check valve, a foreign object lodged under a check valve or a leaky piston seal.
5. Look for metal chips or shavings under the pump D-slides.
6. Traps in the wet glycol power piping sends alternate slugs of glycol and gas to the pump.
7. Insufficient glycol to the Main Piston D-slide ports. Elevate the control valve end of the pump to correct.

GLYCOL PUMPS

"PV" & "SC" SERIES

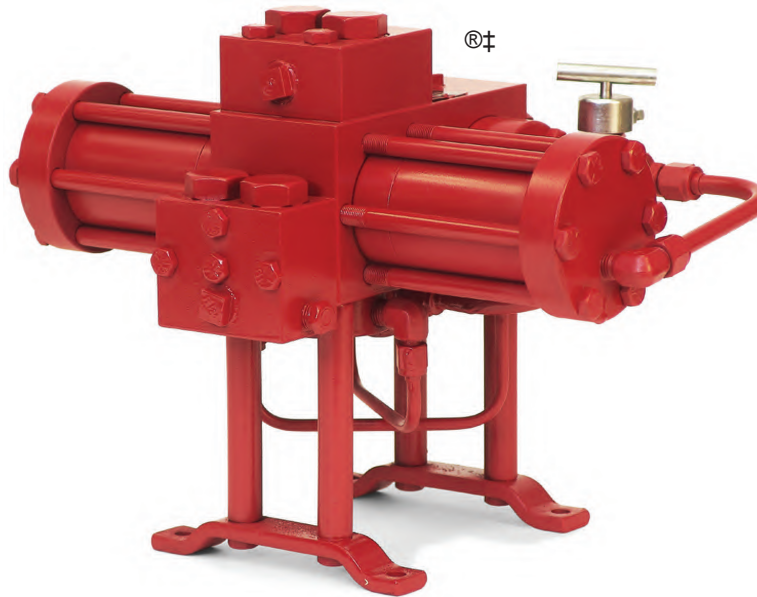

PUMPS AVAILABLE:

"PV" SERIES GLYCOL PUMPS					
Catalog Number	Model Number	Capacity Gal. / Hr.		Working Pressure	
		Min.	Max.**	Min.	Max.
GADHSN	1720 PV	8	40	300	2000
GABHSN	4020 PV	12	40	300	2000
GAFHSN	9020 PV	27	90	300	2000
GAHHSN	21020 PV	66	210	400	2000
GAJHSN	45020 PV	166	450	400	2000

"SC" SERIES GLYCOL PUMPS					
Catalog Number	Model Number	Capacity Gal. / Hr.		Working Pressure	
		Min.	Max.**	Min.	Max.
GACHSN	2020 SC*	8	20	100	500
GAGHSN	5020 SC*	12	50	100	500
GAHHSN	10020 SC*	22	100	100	500
GAKHSN	20020 SC*	60	200	100	500

**Maximum output is affected by system pressure drops. See system operation parameter for maximum output curves.

MAXIMUM DESIGN PRESSURE FOR P.V. AND S.C. MODELS IS 2000 psig

APPLICATIONS:

- Circulating pump for gas glycol dehydrators
- Circulating pump for gas amine desulphurizers

FEATURES:

- Eliminates absorber liquid level controls
- No auxiliary power supply required
- Low gas consumption
- Completely sealed system prevents loss glycol
- No springs or toggles, only two moving assemblies
- Hydraulic "cushioned" check valves with removable seats of hardened stainless steel

OPERATION:

Materials for the vital working parts have been selected for greatest wear resistance. These materials include stainless steel, hard chrome plating, stellite, nylon and teflon. Moving "O" Ring seals are compounded specifically for ethylene glycol service. A complete operational check is given each pump after assembly.

"O" Ring sealed check valve darts are standard in all pumps. Teflon sealed darts are available. Capsule type ball checks are available for 1720 PV, 2015 SC and 4020 PV.

*These pumps are designed for operating pressures between 100 and 500 psig maximum design pressure for all models is 2000 psig.

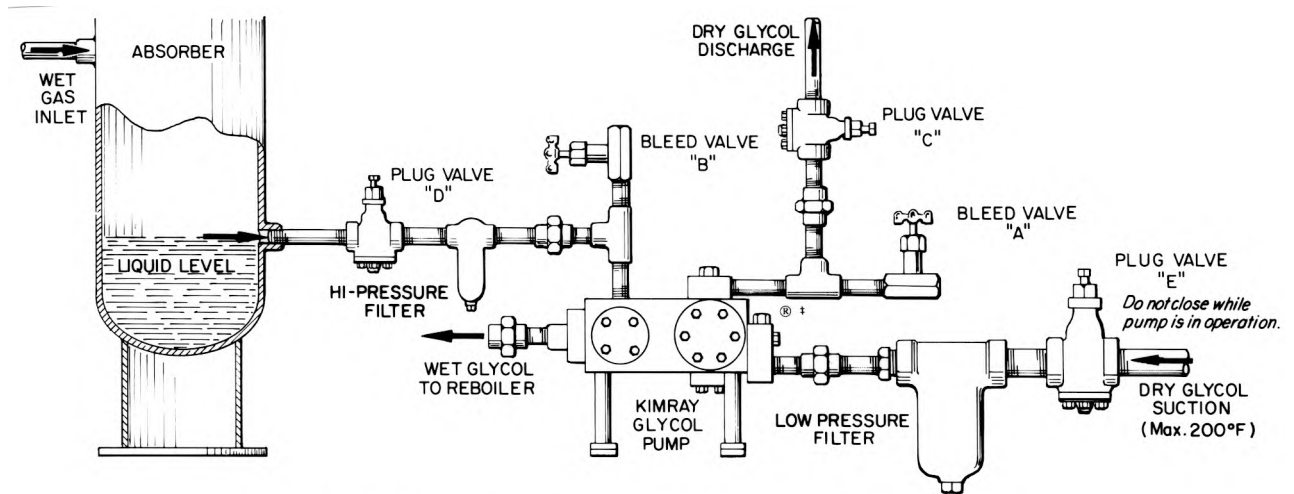

All fittings, filters, valves and strainers shown here are to be furnished by customer.

INSTALLATION:

For maximum pump life a high pressure filter should be installed in the **wet** glycol line between the absorber and pump. Also a low pressure filter or strainer is recommended for the dry glycol suction line between the accumulator and pump.

Adequate heat exchangers must be provided to keep the temperature of fluid flowing through the pump below 200°F.

The following filter and strainer line sizes are recommended minimum:

1720 PV	1/2" NPT
4020 PV & 2020 SC	1/2" NPT
9020 PV & 5020 SC	3/4" NPT
21020 PV & 10020 SC	1" NPT
45020 PV & 20020 SC	1 1/2" NPT

Relief valves "A" and "B" are required for removing pressure from the pump to allow inspection and repair. Relief valve "A" is also used for priming as described below. The plug valves and unions permit the pump and filters to be easily isolated or removed for inspection or repair.

OPERATING PROCEDURE:

1. Close both speed control valves, relief valves "A", "B" and plug valve "C".
2. Open plug valves "D" and "E".
3. Pressure absorber to about 300 psig.
4. With plug valve "C" closed, open relief valve "A".
5. Slowly open both speed control valves until pump is running about 1/3 rated max. strokes per minute. Count one stroke for each DISCHARGE of PUMP. When dry glycol discharges from valve "A" on each stroke, the pump is primed. Close valve "A" and open valve "C". Readjust speed control valves to 1/3 rated max. strokes per minute and continue operating pump until wet glycol returns from the absorber to the pump. This will be evidenced when the pump tries to meter liquid through the speed control valves instead of gas and causes the pump to slow down. Close both speed control valves.
6. Bring absorber to full operating pressure.
7. Adjust speed control valves for desired rate (see capacity chart).
8. Inspect and clean filters and strainers periodically.
9. For preventive maintenance, "O" Rings should be replaced annually. To check "O" Ring seal, close valve "C". If pump continues to run, seals should be replaced.

SYSTEM SHUTDOWN:

1. Close plug valve "D" Allow pump to stop running
2. Close plug valve "C" and "E"
3. Vent pressure from bleed relief "A" and "B"

“PV” & “SC” SERIES
CHARTS & DIMENSIONS

Model Number	Max. Cap		Size of Pipe Connections	Mounting Bolts	Approx. Weight	Max. Strokes Minute	Glycol Output Strokes/Gal.	Glycol Output Gal./Strokes
	G.P.M.	G.P.H.						
1720 PV	.67	40	1/2" N.P.T.	3/8" Dia.	66 Lbs.	40	59	0.017
4020 PV	.67	40	1/2" N.P.T.	3/8" Dia.	66 Lbs.	40	59	0.017
9020 PV	1.5	90	3/4" N.P.T.	1/2" Dia.	119 Lbs.	40	26.3	0.038
21020 PV	3.5	210	1" N.P.T.	1/2" Dia.	215 Lbs.	32	9	0.111
45020 PV	7.5	450	1 1/2" N.P.T.	3/4" Dia.	500 Lbs.	28	3.5	0.283
2020 SC	.33	20	1/2" N.P.T.	3/8" Dia.	66 Lbs.	55	147	0.0068
5020 SC	.83	50	3/4" N.P.T.	1/2" Dia.	119 Lbs.	50	52	0.019
10020 SC	1.67	100	1" N.P.T.	1/2" Dia.	215 Lbs.	48	25	0.040
20020SC	3.33	200	1 1/2" N.P.T.	3/4" Dia.	500 Lbs.	40	8.8	0.114

CIRCULATION RATE GRAPH

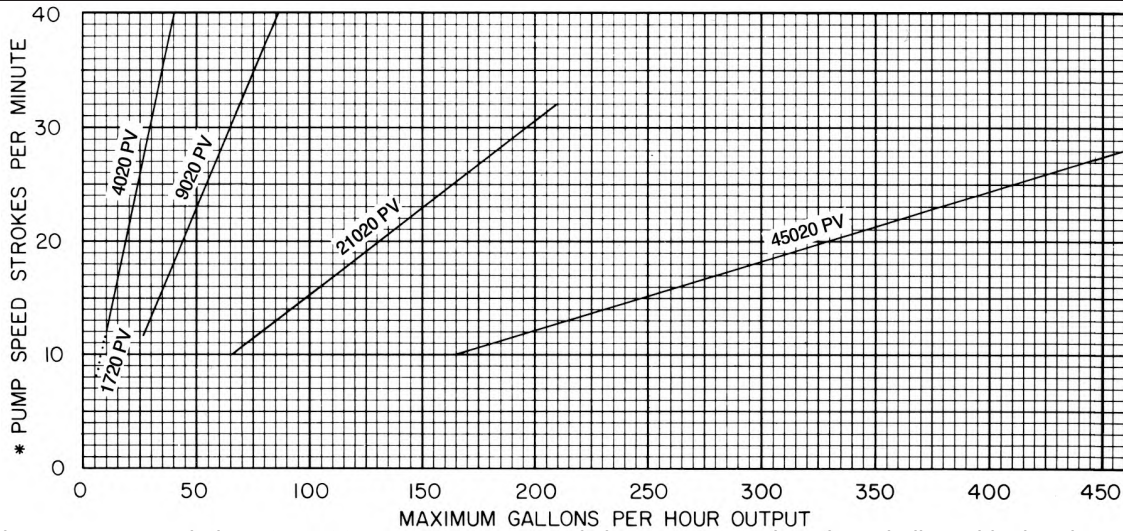

* It is not recommended to attempt to run pumps at speeds less or greater than those indicated in the above graph.

GAS CONSUMPTION

Operating Pressure --p.s.i.g.	300	400	500	600	700	800	900	1000	1100	1200	1300	1400	1500	1600	1700	1800	1900	2000
Cu. Ft./Gallon @ 14.4 & 60°F.	1.7	2.3	2.8	3.4	3.9	4.5	5.0	5.6	6.1	6.7	7.2	7.9	8.3	8.7	9.3	9.8	10.4	10.9

DIMENSIONS

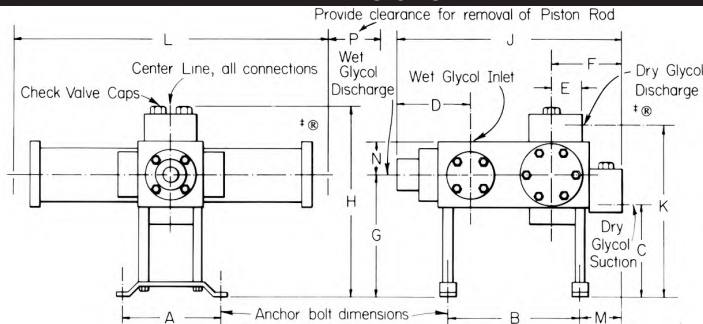

Model Number “PV” Series “SC” Series	Dimensions, Inches													
	A	B	C	D	E	F	G	H	J	K	L	M	N	P
1720 PV	5 1/4	5 11/16	5 3/4	3 7/16	1 1/2	3 1/2	7 1/4	10 7/8	10 3/16	9 5/8	15	2 1/8	1 3/4	3
4020 PV & 2020 SC	5 1/4	5 11/16	5 3/4	3 7/16	1 1/2	3 1/2	7 1/4	10 7/8	10 3/16	9 5/8	15	2 1/8	1 3/4	3
9020 PV & 5020 SC	6 1/4	8 1/4 ± 1/8	6 3/8	5	1 3/4	4 1/4	8 3/4	13 1/4	13 7/8	11 3/4	20	2 1/2	2	3
21020 PV & 10020 SC	7 5/8	10 1/8 ± 1/8	7	5 3/8	2 1/4	5 3/4	9 1/4	14 3/4	16 5/8	13	24	3 3/16	2 1/2	4
45020 PV & 20020 SC	10 3/4	14 ± 1/8	9	6 5/8	2 5/8	6 1/2	11 3/8	19	21 1/8	16 3/8	34	3 3/4	3 1/2	6

"PV" & "SC" SERIES SMALL BORE CYLINDERS

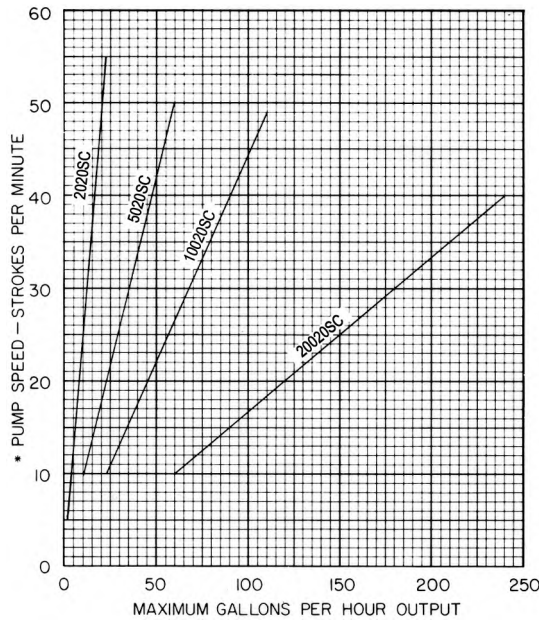

* It is not recommended to attempt to run pumps at speeds less or greater than those indicated in the above graph.

GAS CONSUMPTION

Operating Pressure - psig	100	200	300	400
Cu. Ft./Gal. @ 14.4 & 60°F.	1.0	1.9	2.8	3.7

The "SC" (small cylinder) Series glycol pump was designed to extend the lower operating pressure of the "PV" Series pump downward from 300 psig to 100 psig. Due to increased gas consumption it is recommended to use the "PV" Series pumps at pressures greater than 400 psig.

Any Kimray "PV" Series glycol pump can be field converted to a "SC" Series pump of comparable size (see comparative table below). Likewise, "SC" Series pumps can be converted to "PV" Series pumps. The parts required for these conversions are stocked in kit form. To order conversion kits specify; (existing pump model) conversion kit to (converted pump model). Example: "4020 PV Conversion Kit to 2020 SC."

COMPARATIVE TABLE

"PV" Series Model No.	"SC" Series Model No.
1720-4020	2020 SC
9020	5020 SC
21020	10020 SC
45020	20020 SC

Physical dimensions of "SC" Series pumps are the same as the comparable "PV" Series pumps. See page 8.

PARTS REQUIRED TO CONVERT FROM "PV" TO "SC" SERIES

PART NAME	Quantity Required	PART NUMBER			
		4020 PV to 2020 SC	9020 PV to 5020 SC	21020 PV to 10020 SC	45020 PV to 20020 SC
Cylinder Liner	2	2108	2373	2412	‡1505
Piston	2	1506	776	1507	1508
Piston Seal Retainer	2	1509	1510	1511	1512
"O" Ring	2	156HSN	773HSN	774HSN	329HSN
Back-up Ring	4	1513	1457	1458	‡ 772
"O" Ring	2	154HSN	154HSN	155HSN	1107HSN
Lock Nut (Piston)	2	* _____	906	175	1140
Cylinder "O" Ring	2	773	774	329	

*The piston is the nut for this model and is furnished with a socket head set screw.
 ‡Full cylinder only.
 ‡Model 20020 SC only, requires 8, No. 772 Back-up rings.

GLYCOL PUMPS

MODEL 10020 SC PUMP STEEL

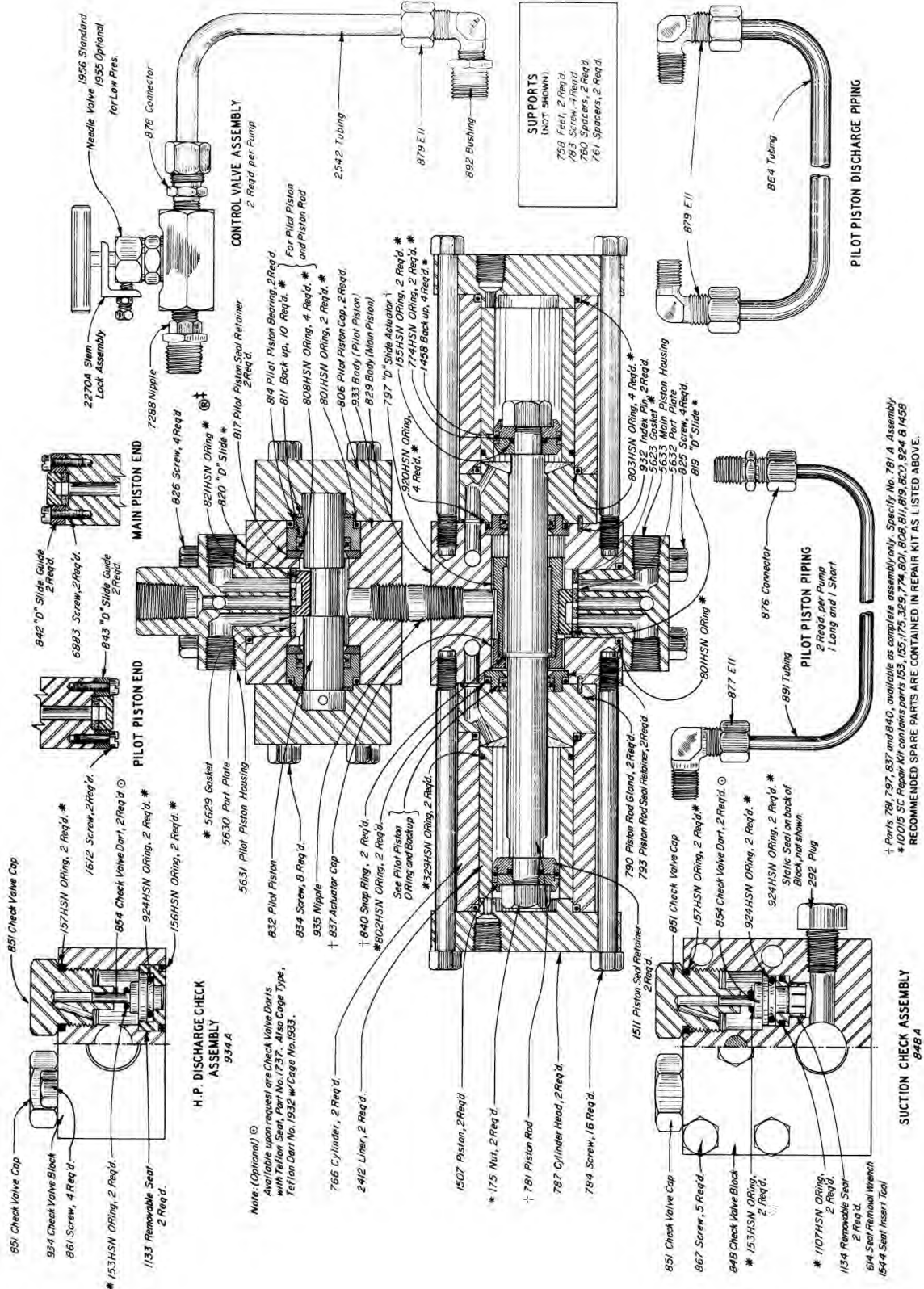

PUMPS AVAILABLE:

NOTES:

CAT. NO.	TYPE	OPER. PRESS. MINIMUM	OPER. PRESS. MAXIMUM	REPAIR KIT
GAHNS	10020 SC	100	500	RJK1-HSN

Kimray is an ISO 9001- certified manufacturer.

G:10.22
Issued 7/20

± Configuration of Glycol pump is a trademark of Kimray, Inc.
www.kimray.com

Current Revision:
update image

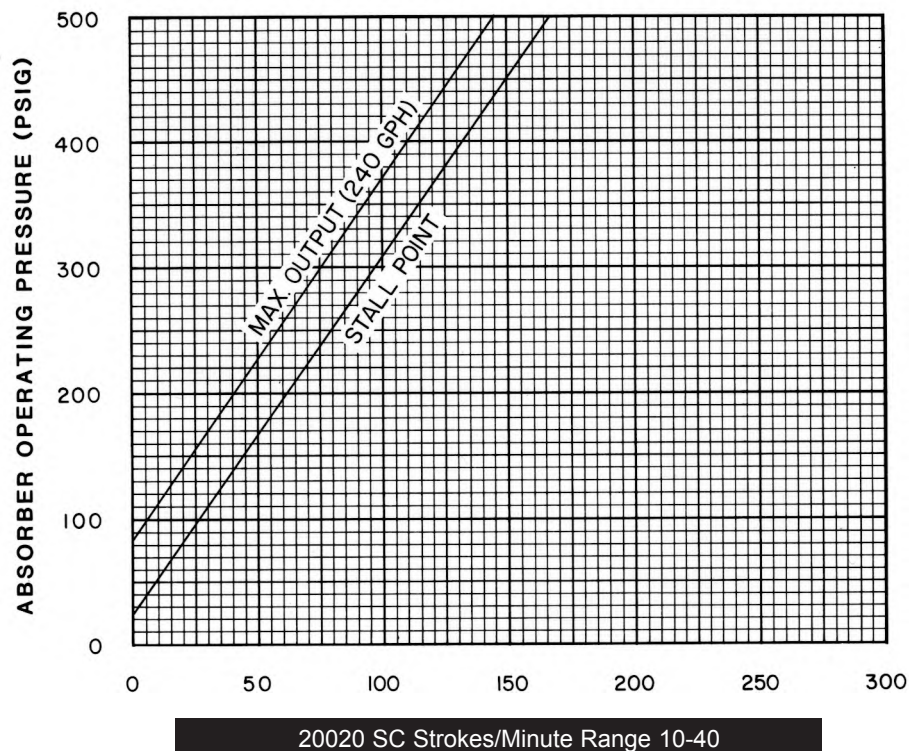
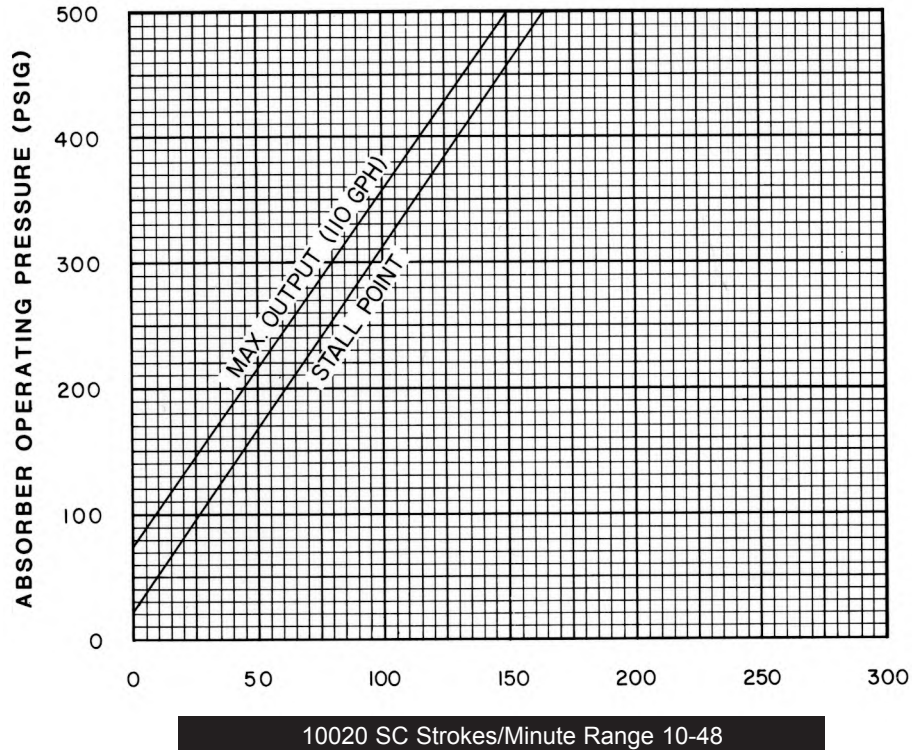

SYSTEM PRESSURE DROPS (PSIG)

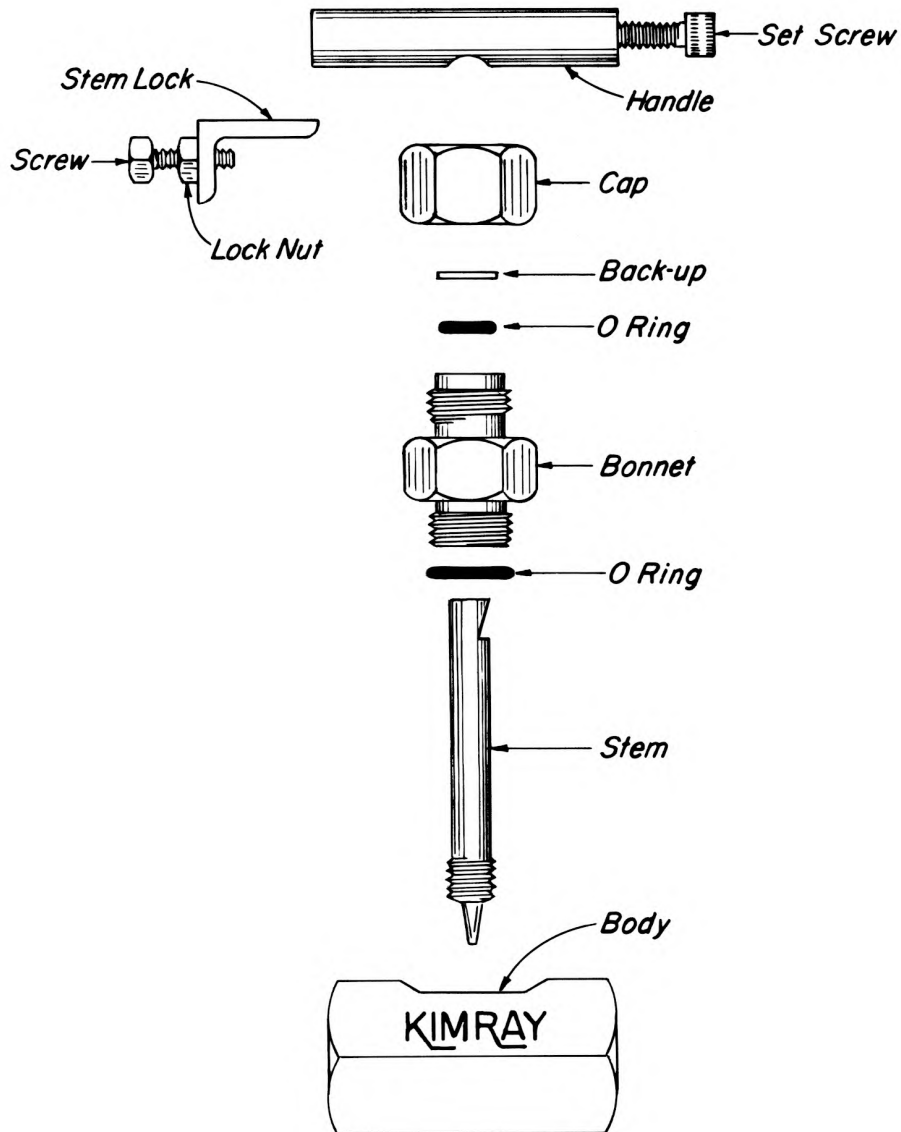

N.P.T. SIZE	VALVE NO.	ORIFICE SIZE	PUMP SIZE	BODY	BONNET	CAP	STEM	HANDLE	SET SCREW	BACK-UP	O-RING	O-RING	STEM LOCK	SCREW	LOCK NUT
TYPE 303 STAINLESS STEEL STANDARD ON ALL PUMPS EXCEPT 45020 PV PUMP															
1/4"	1911	1/16"	1720	1911A	1603D	1603F	1957A	1603B	1964	1978	638HSN	265HSN	6746	6731	6732
1/4"	1957	1/8"	4020	1957C	1603D	1603F	1957A	1603B	1964	1978	638HSN	265HSN	6746	6731	6732
3/8"	1956	3/16"	9020	1956C	1955D	1955F	1956A	1955B	1963	1979	153HSN	2631HSN	6747	6731	6732
1/2"	1955	9/32"	21020	1955C	1955D	1955F	1955A	1955B	1963	1979	153HSN	2631HSN	6747	6731	6732
CARBON STEEL STANDARD ON 45020 PV PUMP ONLY															
3/4"	1954	13/32"	45020	1954C	1954D	1954F	1954A	1954B	1962	1980	154HSN	2131HSN	6748	6731	6732
TYPE 316 STAINLESS STEEL - AVAILABLE ON SPECIAL ORDER AND EXTRA COST															
1/4"	1911S6	1/16"	1720	1911A6	1603D6	1603F6	1957A	1603B	1964	1978	638HSN	265HSN	6746	6731	6732
1/4"	1957S6	1/8"	4020	1957C6	1603D6	1603F6	1957A	1603B	1964	1978	638HSN	265HSN	6746	6731	6732
3/8"	1956S6	3/16"	9020	1956C6	1955D6	1955F6	1956A	1955B	1963	1979	153HSN	2631HSN	6747	6731	6732
1/2"	1955S6	9/32"	21020	1955C6	1955D6	1955F6	1955A	1955B	1963	1979	153HSN	2631HSN	6747	6731	6732
3/4"	1954S6	13/32"	45020	1954C6	1954D6	1954F6	1954A	1954B	1962	1980	154HSN	2131HSN	6748	6731	6732

Kimray Glycol Pumps are available with check valve blocks for split discharge to serve two absorbers on a dehydration unit. On an original pump purchase there is no extra charge for this check block.

An accurately divided flow is assured since each absorber is served by one cylinder of the double acting pump.

For an installation of this type only one suction line is necessary. Also the high pressure wet glycol return may be manifolded through one filter or strainer to the pump.

When ordering any Kimray pump for this service, specify the pump number and service. For example: 4020 PV for "split discharge".

To order Check Valve Blocks for Split Discharge Assemblies add an "A" to the Check Valve Body number. Example: 1194A to order the assemblies with viton O Rings add a "V" to Check Valve Assemblies number; Example: 1194AV

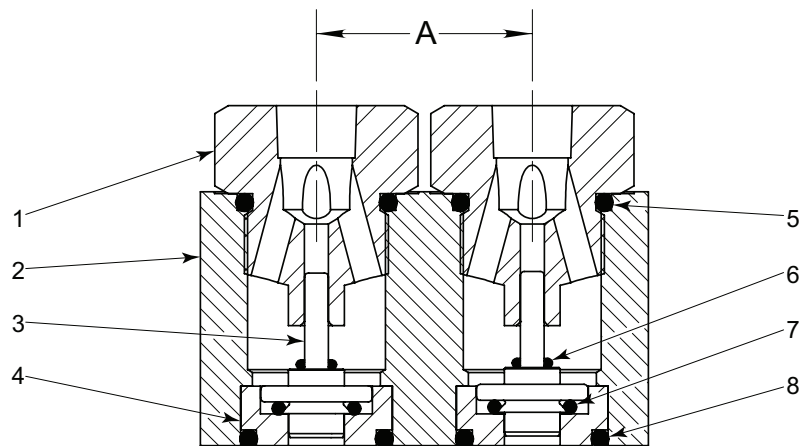

PART NUMBERS FOR INDICATED PUMPS							
ITEM NUMBER	PART NAME	QTY REQ'D	1720 PV	4020 PV and 2020 SC	9020 PV and 5020 SC	21020 PV and 10020 SC	45020 PV and 20020 SC
1	CHECK VALVE CAP	2	1327	1327	1114	1199	1198
2	CHECK VALVE BODY	1	1194	1194	1195	1196	1197
3	DART	2	1307	1307	853	854	1163
4	REMOVABLE SEAT	2	1152	1152	1131	1133	1173
5	"O" RING, CAP	2	155HSN	155HSN	156HSN	157HSN	801HSN
6	"O" RING, SNUBBER	2	647HSN	647HSN	647HSN	153HSN	265HSN
7	"O" RING, DART	2	855HSN	855HSN	154HSN	924HSN	156HSN
8	"O" RING, SEAT	2	491HSN	491HSN	1151HSN	156HSN	801HSN
TAPPED HOLE SIZE		NPT	1/4	1/4	3/8	1/2	3/4
DIMENSION "A"		Inches	1 1/2	1 1/2	1 11/16	2 5/16	3
ASSEMBLY			1194A		1195A	1196A	1197A