

APPLICATIONS:

Liquid or gas systems where a 0 to 125 psig adjustable back pressure is desired, such as treaters, free water knockouts, pressure vessels, vent lines on separators, flow treaters, compressor stations, and gas gathering systems.

FEATURES:

- Single adjustment
- Single soft seat
- Removable valve seat
- Internal sense line
- Minimum maintenance
- All internal parts can be removed with valve in line
- Spring adjustment
 - 0 to 10 psig.
 - 10 to 20 psig.
 - 20 to 40 psig.
 - 40 to 65 psig.
 - 65 to 90 psig.
 - 80 to 125 psig.

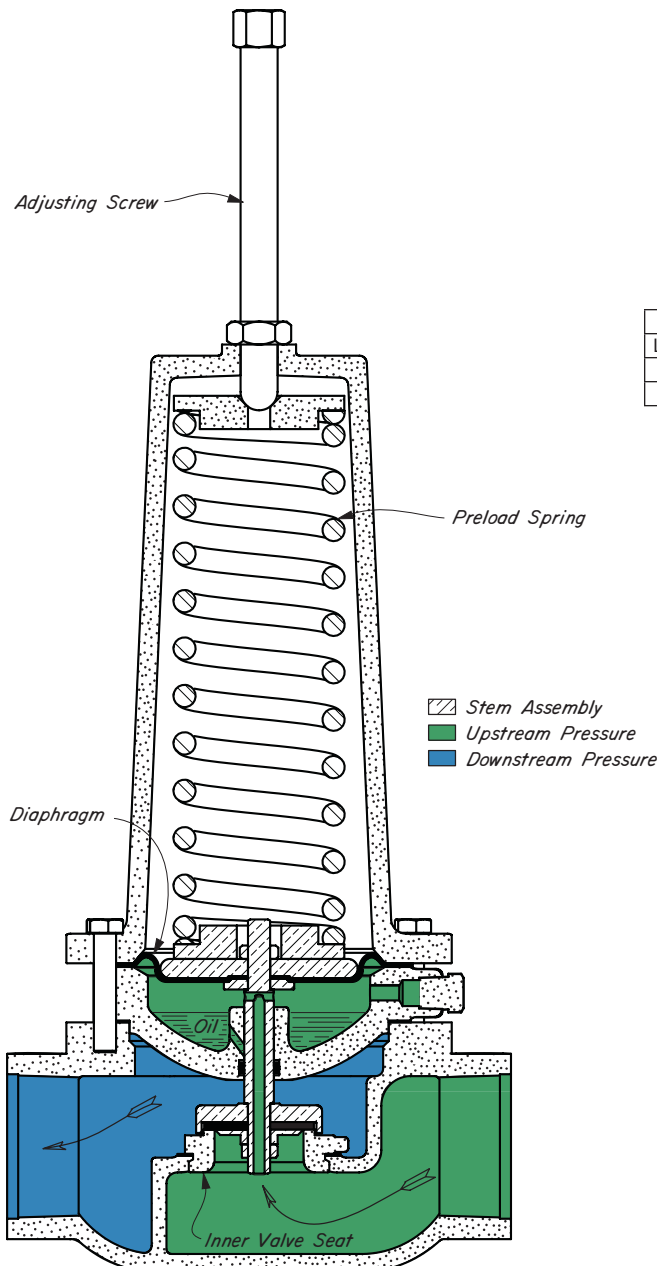

CERTIFICATIONS:

Canadian Registration Number (CRN):
 0C15676.24567890NTY (Ductile)
 0C15331.24567890NTY (Steel)

CONSTRUCTION:

Body and housings are available in cast iron, ductile iron or steel. Valve stem is 303 stainless steel. Spring is stainless steel. Diaphragm and seating materials are oil resistant synthetic rubber or polyurethane. After assembly each valve is given a complete operational test.

OPERATION:

The Stem Assembly is the only moving unit in the motor valve. The PRELOAD SPRING loads the Stem Assembly and is opposed by Upstream Pressure (Green) on the under side of the DIAPHRAGM plus the differential of Upstream Pressure (Green) minus Downstream Pressure (Blue) across the INNER VALVE SEAT.

An increase in Upstream Pressure (Green) exceeding the set pressure of the PRELOAD SPRING moves the Stem Assembly upward, opening the INNER VALVE SEAT.

A decrease in Upstream Pressure (Green) decreases the force on the INNER VALVE SEAT and DIAPHRAGM allowing the PRELOAD SPRING to move the Stem Assembly downward reducing the flow from Upstream Pressure (Green) to Downstream Pressure (Blue).

The interaction between the PRELOAD SPRING and the Upstream Pressure (Green) on the INNER VALVE SEAT and the DIAPHRAGM will cause the valve to open or close the amount required to maintain the Upstream Pressure (Green) set by the ADJUSTING SCREW.

Cf & Cv VALUES			
Line Size	Trim Size	Cf	Cv
1"	.50"	0.86	5.6
2"	1.25"	0.84	24.0



Kimray is an ISO 9001- certified manufacturer.

LOW PRESSURE MOTOR VALVES



MT BP5 SPRING LOADED BACK PRESS. w/REDUCED INNER VALVE
DUCTILE IRON

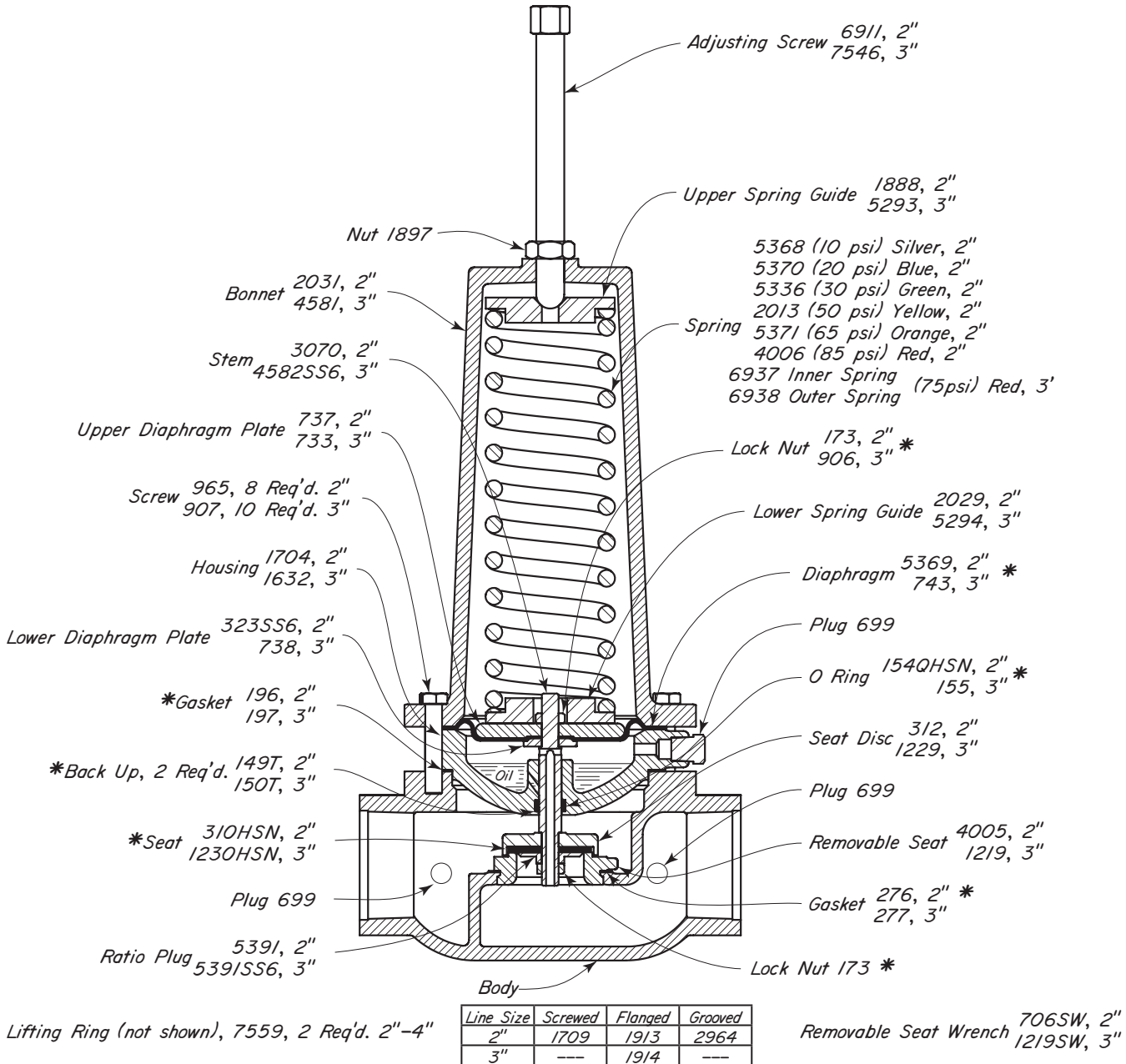

THRU VALVES AVAILABLE:

CAT. NO.	SIZE TYPE	MOTOR VALVES	OPER PRESS	MAX. W.P.	KIT
ALU1	2" SCR.D.	201 SMT BP5-D	0-10	300	RTB1
ALU2	2" SCR.D.	202 SMT BP5-D	10-20	300	RTB1
ALU4	2" SCR.D.	204 SMT BP5-D	20-40	300	RTB1
ALU6	2" SCR.D.	206 SMT BP5-D	40-65	300	RTB1
ALU9	2" SCR.D.	209 SMT BP5-D	65-90	300	RTB1
ALU12	2" SCR.D.	212 SMT BP5-D	80-125	300	RTB1
ALV1	2" GRVD.	201 GMT BP5-D	0-10	300	RTB1
ALV2	2" GRVD.	202 GMT BP5-D	10-20	300	RTB1
ALV4	2" GRVD.	204 GMT BP5-D	20-40	300	RTB1
ALV6	2" GRVD.	206 GMT BP5-D	40-65	300	RTB1
ALV9	2" GRVD.	209 GMT BP5-D	65-90	300	RTB1

NOTES:

CAT. NO.	SIZE TYPE	MOTOR VALVES	OPER PRESS	MAX. W.P.	KIT
ALV12	2" GRVD.	212 GMT BP5-D	80-125	300	RTB1
ALW1	2" FLGD.	201 FMT BP5-D	0-10	250	RTB1
ALW2	2" FLGD.	202 FMT BP5-D	10-20	250	RTB1
ALW4	2" FLGD.	204 FMT BP5-D	20-40	250	RTB1
ALW6	2" FLGD.	206 FMT BP5-D	40-65	250	RTB1
ALW9	2" FLGD.	209 FMT BP5-D	65-90	250	RTB1
ALW12	2" FLGD.	212 FMT BP5-D	80-125	250	RTB1
ENZ5	3" FLGD.	310 FMT BP5-D	10-75	250	RTD1

*These are recommended spare parts and are stocked as repair kits.
For dimensions refer to Table of Contents.

Kimray is an ISO 9001- certified manufacturer.

CAPACITY - Bbls. Water/Day

SINGLE ACTING MOTOR VALVES					
PRESSURE DROP ACROSS VALVE PSIG.	VALVE SIZE-INCHES				
	1	2	3	4	6
1	105	745	1,760	3,350	7,800
2	150	1,060	2,500	4,900	11,000
3	180	1,300	3,050	6,100	13,500
4	210	1,500	3,500	7,000	15,600
5	235	1,700	3,900	7,800	17,500
10	330	2,300	5,600	11,000	24,700
15	405	2,900	6,800	13,500	30,200
20	465	3,300	7,900	15,600	34,900
30	575	4,100	9,600	19,200	42,700
40	660	4,700	11,100	22,100	49,300
50	740	5,300	12,400	24,800	55,200
60	810	5,800	13,600	27,100	60,500
70	875	6,200	14,700	29,300	65,400
80	935	6,700	15,700	31,300	69,800
100	1,045	7,500	17,600	33,500	78,200
125	1,170	8,400	19,700	38,200	87,500

WITH REDUCED INNER VALVES					
PRESSURE DROP ACROSS VALVE PSIG.	VALVE SIZE-INCHES				
	1	2	3	4	6
1	26	290	515	835	1,950
2	37	410	735	1,225	2,750
3	45	510	895	1,525	3,370
4	52	590	1,025	1,750	3,900
5	59	660	1,140	1,950	4,375
10	82	900	1,640	2,750	6,175
15	101	1,130	2,000	3,370	7,550
20	116	1,290	2,320	3,900	8,725
30	145	1,600	2,820	4,800	10,675
40	165	1,840	3,260	5,500	12,300
50	185	2,070	3,640	6,200	13,800
60	200	2,260	4,000	6,750	15,100
70	220	2,420	4,300	7,300	16,350
80	230	2,620	4,600	7,800	17,450
100	260	2,940	5,150	8,350	19,500
125	290	3,280	5,750	9,800	21,900

For gravity correction, multiply the above figures by $\sqrt{\frac{1}{G}}$
 Where "G" is the specific gravity of the flowing liquid.

CAPACITY - Blds. Water/Day, Steady Row

DOUBLE ACTING MOTOR VALVES

PRESSURE DROP ACROSS VALVE PSIG.	VALVE SIZE-INCHES				
	1	2	3	4	6
1	405	1,520	3,150	5,830	13,150
2	573	2,150	4,460	8,250	18,600
3	702	2,630	5,450	10,700	22,800
4	810	3,040	6,300	11,700	26,300
5	905	3,400	7,030	13,100	29,400
10	1,280	4,800	9,980	18,500	41,700
15	1,570	5,880	12,200	22,600	50,900
20	1,810	6,800	14,100	26,100	58,800
30	2,220	8,320	17,300	31,900	72,000
40	2,560	9,600	19,900	36,900	83,100
50	2,860	10,750	22,300	41,300	93,000
60	3,130	11,780	24,400	45,200	102,000
70	3,380	12,700	26,400	48,800	110,000
80	3,620	13,600	28,200	52,100	117,500
100	4,050	15,200	31,500	58,300	131,500
125	4,520	16,900	35,200	65,100	147,000

WITH REDUCED INNER VALVES

PRESSURE DROP ACROSS VALVE PSIG.	VALVE SIZE-INCHES				
	1	2	3	4	6
1	101	740	1,080	1,650	3,740
2	143	1,040	1,525	2,340	5,330
3	175	1,280	1,860	2,860	6,530
4	200	1,475	2,150	3,300	7,550
5	225	1,650	2,400	3,700	8,400
10	320	2,330	3,400	5,250	11,950
15	390	2,875	4,150	6,400	14,600
20	450	3,300	4,800	7,400	16,850
30	555	4,050	5,900	9,050	20,600
40	640	4,650	6,800	10,500	23,800
50	710	5,200	7,600	11,700	26,600
60	780	5,700	8,350	12,800	29,200
70	845	6,150	9,000	13,800	31,500
80	905	6,600	9,650	14,800	33,600
100	1,010	7,375	10,800	16,500	37,400
125	1,105	8,200	12,000	18,450	42,000

ADJUSTABLE DOUBLE ACTING WITH REDUCED INNER VALVES

PRESSURE DROP ACROSS VALVE PSIG.	ADAB
1	101
2	143
3	175
4	200
5	225
10	320
15	390
20	450
30	555
40	640
50	710
60	780
70	845
80	905
100	1,010
125	1,105

For gravity correction, multiply the above figures by $\sqrt{\frac{1}{G}}$
 Where "G" is the specific gravity of the flowing liquid.

MT (SINGLE ACTING MOTOR VALVE)
MT-5 (WITH REDUCED INNER VALVES)

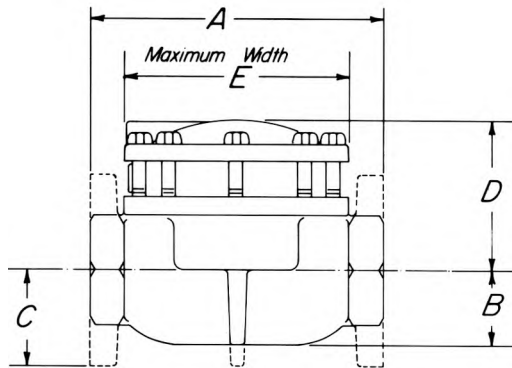

MT-2DA, MT-4DA (DOUBLE ACTING MOTOR VALVE)
MT-2DA5, MT-4DA5 (WITH REDUCED INNER VALVES)

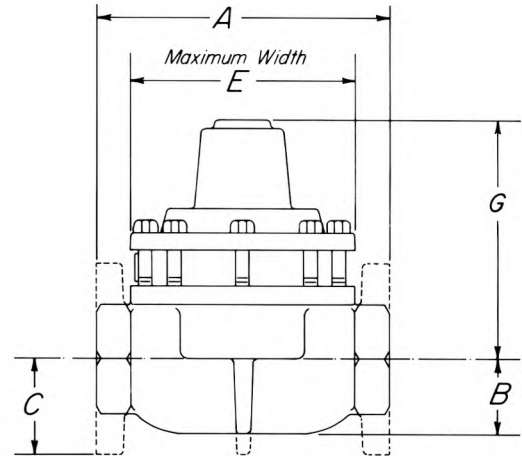

MT-DA (DOUBLE ACTING MOTOR VALVE)
MT-DA5 (WITH REDUCED INNER VALVES)

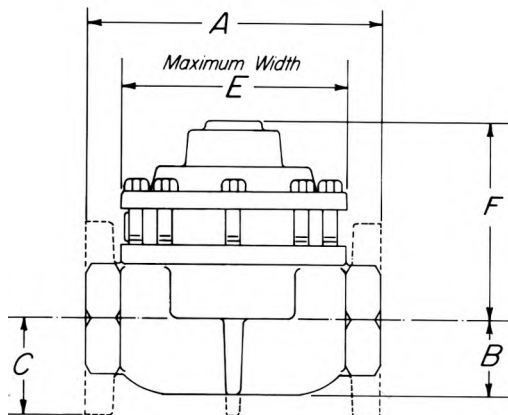

MT-ADA, MT ADAB (ADJUSTABLE DOUBLE ACTING)
MT BP, MT BP5 (SPRING LOADED BACK PRESSURE)

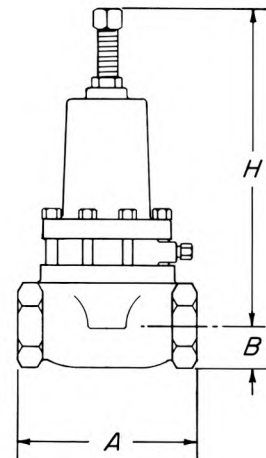

LINE SIZE	BODY STYLE	A	B	C	D	E	F	G	H
1"	SCRD	4 3/8	1 1/8		2 3/4	3 3/8	3 3/8	3 3/8	8
2"	SCRD	8 1/2	2 1/8		4 3/8	5 7/8	6 7/8	6 7/8	18 1/2
	FLGD	9		3	4 3/8	5 7/8	6 7/8	6 7/8	18 1/2
3"	GRVD	8 3/4	2 1/8		4 3/8	5 7/8	6 7/8	6 7/8	18 1/2
	SCRD	12	3 1/16		5 7/8	8	8	8	20
4"	FLGD	12 3/16		3 3/4	5 7/8	8	8	8	20
	SCRD	15	4		7 1/2	9 3/4	9 1/2	9 1/2	
6"	FLGD	15 1/8		4 1/2	7 1/2	9 3/4	9 1/2	9 1/2	
	FLGD	22 1/8		5 1/2	11	16	15 1/4		

FLANGE DIMENSIONS ARE ASA 150 LB. STANDARD.