

DISCONTINUED ITEM
Some of the data on this
document may not be current



LIQUID DUMP VALVES PNEUMATIC OPERATED

**PISTON BALANCED THROTTLING FAIL CLOSE
MODEL PP**

APPLICATION:

Used as oil or water dump valves on separators, treaters, knockouts, and other similar liquid accumulators. For back pressure or pressure reducing applications with pressure pilots.

FEATURES:

- Piston balanced seat assembly
- 30 psig maximum actuating pressure
- Fail Close service.
- All internal parts can be removed with valve in-line
- Reinforced oil resistant synthetic rubber diaphragms & seats
- Trim contoured for throttle or on/off service
- Bubble tight shut-off at full range of pressure

CERTIFICATIONS:

Canadian Registration Number (CRN):
0C15804.24567890NTY (Ductile)
Kimray is an ISO 9001- certified manufacturer.

- Stem and Seat Assembly
- Actuator Pressure
- Upstream Pressure
- Downstream Pressure

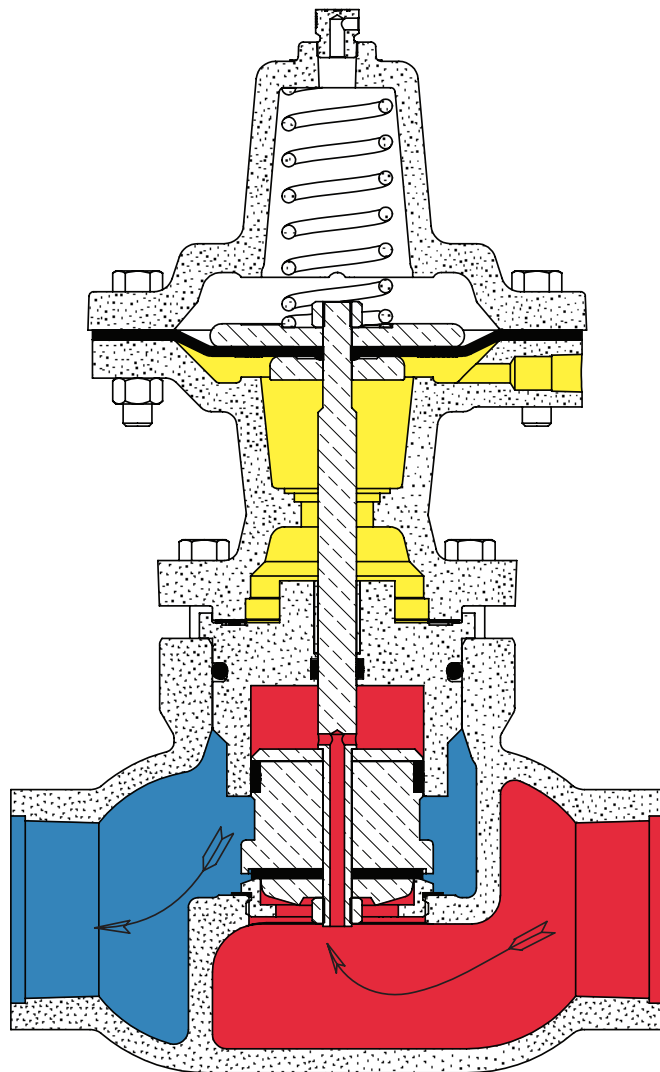

2" & 3" have been discontinued



Standard Configuration Code †	Order Code	Line Size	Connection Type	Body Type	Max Δ P psig	Max. W.P. psig ††	Cv	Cf
DPP2SATDF1S	EMS	2"	NPT	Thru	125	500	47.0	0.75
DPP2ARTDF1S	EMT		150RF					
DPP3SATDF1S	EMU	3"	NPT					
DPP3ARTDF1S	EMV		150RF					
DPP4ARTDF1S	EMW	4"	150RF			250	89.0	
					160			

NOTES:

For standard & optional seals, metals, Cf Cv values, material specifications & dimensions see technical data on pages 04:I - 04:III
 † For Corrosive service remove last "S" & replace with "C"
 † For code builder see page 04:00.2
 †† Max W.P. values based on -20°F to 100°F.

All Pictures shown are for illustration purpose only. Actual product may vary due to product enhancement.

DISCONTINUED ITEM
Some of the data on this
document may not be current

LIQUID DUMP VALVES PNEUMATIC OPERATED

KIMRAY INC.®

PISTON BALANCED THROTTLING FAIL CLOSE
MODEL PP PARTS DRAWING

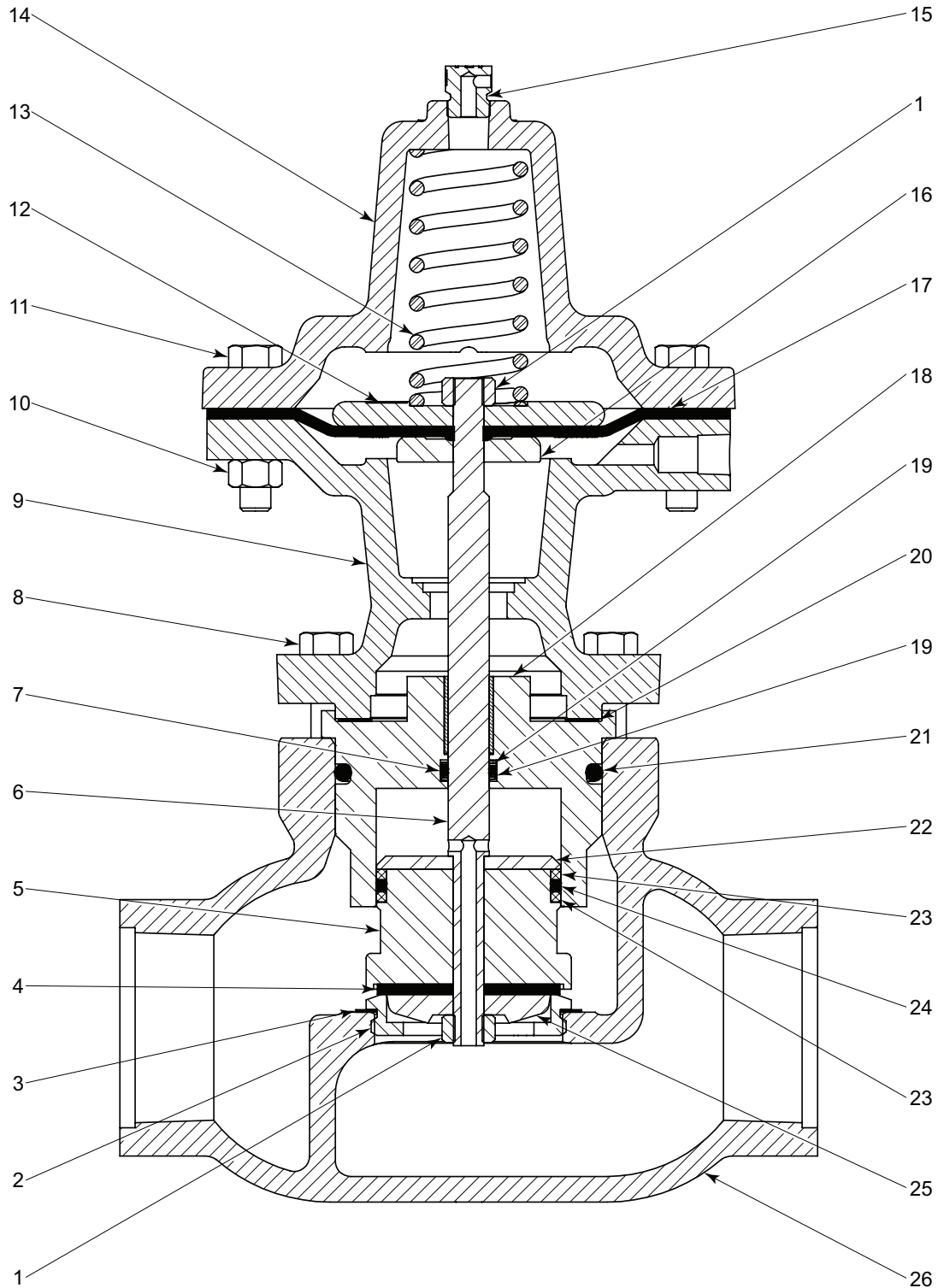

All Pictures shown are for illustration purpose only. Actual product may vary due to product enhancement.

DISCONTINUED ITEM
Some of the data on this
document may not be current



LIQUID DUMP VALVES PNEUMATIC OPERATED

**PISTON BALANCED THROTTLING FAIL CLOSE
MODEL PP PARTS LIST**

2" & 3" have been discontinued

ITEM	QTY.	DESCRIPTION	PART NO.					
			STANDARD			CORROSIVE		
			2 INCH	3 INCH	4 INCH	2 INCH	3 INCH	4 INCH
1	2	Lock Nut ◊ *	173	174SS6		173SS6	174SS6	
2	1	Removable Seat ◊	5214	5215D	5216	5214SS6	5215SS6	5216SS6
3	1	Gasket ◊ *	276	277	196	276	277	196
4	1	Seat ◊ *	5211HSN	5212HSN	5213HSN	5211HSN	5212HSN	5213HSN
5	1	Piston ◊	5208	5209	5210SS6	5208SS6	5209SS6	5210SS6
6	1	Stem ◊	5193	5194	5195	5193SS6	5194SS6	5195SS6
7	1	Quad Ring ◊ *	154QHSN	155QHSN	155Q	154QHSN	155QHSN	155Q
8	(Qty)	Bolt	833 x (6)		833 x (8)	833 x (6)		833 x (8)
9	1	Housing	1689	1868D	5200	1689 ‡	1868D ‡	5200 ‡
10	(Qty)	Nut	241 x (8)	241 x (10)	241 x (12)	241 x (8)	241 x (10)	241 x (12)
11	(Qty)	Bolt	236 x (8)	191 x (10)	192 x (12)	236 x (8)	191 x (10)	192 x (12)
12	1	Upper Diaph. Plate	732	1476	734	732	1476	734
13	1	Spring	5188	621	5192	5188	621	5192
14	1	Bonnet	1665	718	719	1665 ‡	718 ‡	719 ‡
15	1	Breather Plug	147			147		
16	1	Lower Diaph. Plate	5289	5224	739	5289	5224	739
17	1	Diaphragm *	7053	743	744	7053	743	744
18	1	Cylinder	5202	5203SS6	5204SS6	5202SS6	5203SS6	5204SS6
19	2	Back Up ◊ *	149T	150T		149T	150T	
20	1	Gasket ◊ *	5199	5223	1901	5199	5223	1901
21	2	O-Ring ◊ *	329HSN	330HSN	331	329HSN	330HSN	331
22	1	Seal Retainer ◊	5205	5206SS6	5207	5205SS6	5206SS6	5207SS6
23	2	Back Up ◊ *	1458	772	5201	1458	772	5201
24	1	Quad Ring ◊ *	774QHSN	329QHSN	1872Q	774QHSN	329QHSN	1872Q
25	1	Ratio Plug ◊	177SS6	178	179	177SS6	178	179
26	1	Body						
		NPT Thru	5217D	5219D	----	5217D ‡	5219D ‡	----
		150RF Thru	5218D	5220D	5222D	5218D ‡	5220D ‡	5222D ‡
2	Lifting Ring (not shown)	7559			7559			
					‡ Coated Parts available with "E" shell material			
Cage Assemblies			CLE	CLG	CLI	CLES6	CLGS6	CLIS6
			◊ These parts are stocked as Cage Assemblies.					
Repair Kits			RUMD	RUND	RUOD	RUMD	RUND	RUOD
			* These parts are recommended spare parts and are stocked as repair kits.					

DISCONTINUED ITEM
Some of the data on this
document may not be current



LIQUID DUMP VALVES PNEUMATIC OPERATED

FLOW COEFFICIENT

Table 1 - Flow Coefficient(Cv) for Pneumatic Dump Valves													
Line Size	Trim Size in. (mm)	Trim Type	Cf	Valve Opening Percentage									
				10	20	30	40	50	60	70	80	90	100
Diaphragm Balanced													
2"	1 1/2 in (38mm)	Linear (Nominal)	0.79	5.0	8.5	11.7	14.6	17.0	19.0	20.5	21.6	22.6	23.3
3"	2 1/4 in (57 mm)		0.79	6.7	11.1	15.6	20.3	24.8	29.2	33.4	37.2	40.7	43.8
4"	3 in (76 mm)		0.79	12.0	18.9	25.8	32.8	39.9	46.9	53.7	60.0	65.7	70.1
6"	4.88 in (124 mm)		0.79	14.2	21.0	31.6	61.2	98.3	139	179	217	250	277
Low Pressure High Volume Piston Balanced Throttling													
2" thru	1 1/2 in (38mm)	Linear (Nominal)	0.75	5.7	8.4	12.0	14.9	17.6	19.8	22.3	24.4	26.2	28.9
	2 in (51 mm)		0.75	8.3	15.3	21.5	27.2	31.6	36.0	39.3	41.6	44.0	45.8
2" angle	1 1/2 in (38mm)		0.75	3.7	7.9	12.5	15.7	18.6	21.4	24.1	27.2	30.1	33.3
	2 in (51 mm)		0.75	9.7	16.1	23.3	29.2	35.1	39.3	43.6	46.5	49.4	51.4
3" thru	2 in (51 mm)		0.75	11.6	21.5	30.5	38.6	45.7	51.3	55.6	59.1	61.6	64.0
	3 in (76 mm)		0.75	17.0	32.3	46.0	58.6	70.4	79.6	87.4	94.0	98.7	103
3" angle	2 in (51 mm)		0.75	12.5	22.9	32.2	41.8	49.4	56.2	60.8	65.3	68.4	71.7
	3 in (76 mm)		0.75	18.8	34.8	49.0	63.7	75.6	86.7	93.9	101	107	113
4" thru	3.75 in (95 mm)		0.75	17.8	32.9	48.6	61.2	73.1	84.8	94.5	102	108	114
	3 in (76 mm)		0.75	22.7	42.0	61.3	76.2	91.3	106	118	128	135	142
4" angle	3.75 in (95 mm)		0.75	18.4	35.5	52.0	67.9	84.7	96.4	110	120	130	137
	3 in (76 mm)		0.75	23.6	44.7	64.2	83.2	103	117	132	142	154	162
Piston Balanced Throttling													
2"	2 in (51 mm)	Linear (Nominal)	0.75	6.6	12.3	18.4	24.2	29.5	34.1	38.0	41.2	44.0	47.0
3"	3 in (76 mm)		0.75	12.7	18.7	29.0	41.0	52.9	63.4	71.9	78.4	83.7	89.0
4"	3 in (76 mm)		0.75	11.7	18.1	24.8	36.8	58.3	86.1	114	137	152	160

Kimray flow equations conform to ANSI/ISA - 75.01.01-2002
Kimray inherent flow characteristics conform to ANSI/ISA 75.11.01 -1985

DISCONTINUED ITEM
 Some of the data on this
 document may not be current

LIQUID DUMP VALVES PNEUMATIC OPERATED



DIMENSIONS

PH ANGLE DIMENSIONS

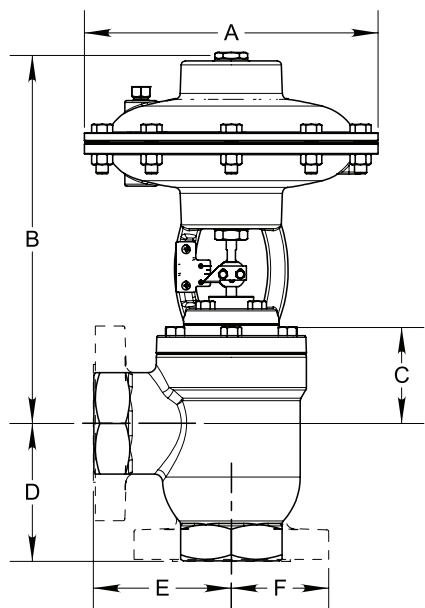

PH THRU DIMENSIONS

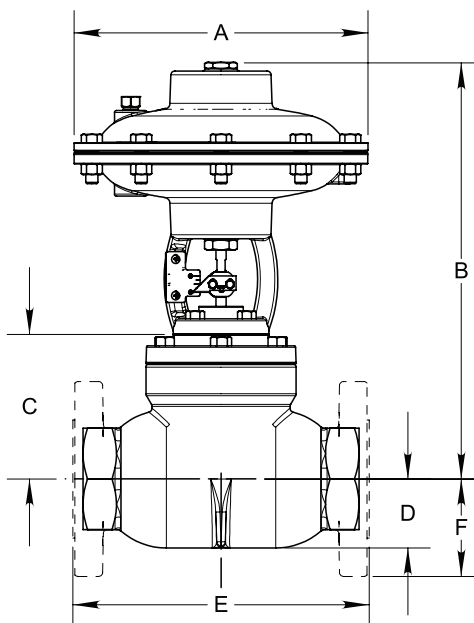

VALVE	A	B	C	D	E	F
2" SA & AR	9 1/16	11 9/32	2 29/32	4 1/4	4 1/4	3
3" SA & AR	12 7/8	15 9/32	4 1/32	5 1/2	5 1/2	3 3/4
4" AR	12 7/8	15 5/32	3 7/8	6 1/2	6 1/2	4 1/2

VALVE	A	B	C	D	E	F
2" SA	9 1/16	12 13/16	4 7/16	2 1/8	8 1/2	3
2" AR	9 1/16	12 13/16	4 7/16	2 1/8	9 1/8	3
3" SA	12 7/8	17 5/32	5 29/32	2 7/8	12	3 3/4
3" AR	12 7/8	17 5/32	5 29/32	2 7/8	12 3/16	3 3/4
4" AR	12 7/8	15 5/32	6 7/32	3 21/32	15	4 1/2

PD, PE, PP, PQ ANGLE DIMENSIONS

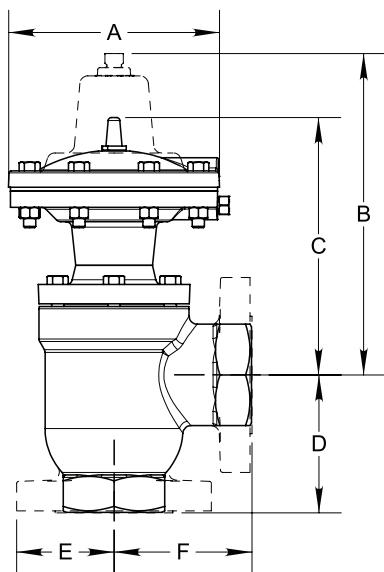

PD, PE, PP, PQ ANGLE DIMENSIONS

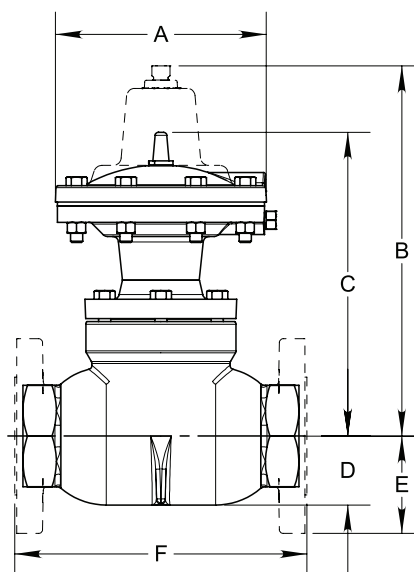

VALVE	A	B	C	D	E	F
2" SA & AR	6 1/2	9	8 1/2	4 1/4	3	4 1/4
3" SA & AR	8 1/2	11 3/4	10 1/4	5 1/2	3 3/4	5 1/2
4" SA & AR	8 1/2	12 1/2	11	6 1/2	4 1/2	6 1/2
6" SA & AR	10 3/4	—	19 3/4	10 1/4	5 1/2	7 11/16

VALVE	A	B	C	D	E	F
2" SA	6 1/2	10 3/8	9 7/8	2 1/8	—	8 1/2
2" AR	6 1/2	10 3/8	9 7/8	—	3	9
3" SA	8 1/2	13 5/16	11 9/16	2 7/8	—	12
3" AR	8 1/2	13 5/16	11 9/16	—	3 3/4	12 3/16
4" SA	8 1/2	14 7/8	13 3/8	—	4 1/2	15 1/8
6" SA	10 3/4	—	19 3/4	—	5 1/2	22

All Pictures shown are for illustration purpose only. Actual product may vary due to product enhancement.

DISCONTINUED ITEM
 Some of the data on this
 document may not be current



LIQUID DUMP VALVES PNEUMATIC OPERATED

SEALS SPECIFICATIONS

Table 2 - Seal Options		
Part	Standard Material	Optional Material
O-rings	HSN	FKM
Diaphragm	HSN	FKM
Seat	HSN	FKM

Table 3 - Seal Specifications			
		HIGHLY SATURATED NITRILE	FKM
Kimray Suffix		HSN	V
Resistance	Abrasion	G-E	G
	Acid	G-E	G-E
	Chemical	F	E
	Cold	G	P
	Flame	P	E
	Heat	E	E
	Oil	E	E
	Ozone	G	G-E
	Set	G	G-E
	Tear	F	F
	Water/Steam	E	P
	Weather	G	E
	CO2	G	G
	H2S	F	P
	Methanol	E	P
Properties	Dynamic	G	G
	Electrical	F	F
	Impermeability	G	G
	Tensile Strength	G-E	G
	Temp. Range		-20° to +300°F
		-29° to +149°C	-26° to +204°C
RATINGS: P-POOR, F-FAIR, G-GOOD, E-EXCELLENT			

LIQUID DUMP VALVES PNEUMATIC OPERATED

MATERIAL SPECIFICATIONS



Table 4 - Material Options - Diaphragm Balanced & Piston Balanced Throttle

Part Description	Standard Material	Corrosive Material
Body	Ductile (ASTM A395)	Ductile (ASTM A395) + Kimcoat
Ratio Plug	2 & 3 inch Delrin (ASTM D4181), 4 & 6 inch (ASTM A395)	17-4PH (ASTM A564)
Cage	2 & 3 inch Delrin (ASTM D4181), 4 & 6 inch (ASTM A395)	Ductile (ASTM A395) + Kimcoat
Stem	303SS (ASTM A582)	316SS (ASTM A479)
Bonnet	Ductile (ASTM A395)	Ductile (ASTM A395) + Kimcoat
Piston	303SS (ASTM A582)	316SS (ASTM A479)
Cylinder	303SS (ASTM A582)	316SS (ASTM A479)

Table 5 - Material Options - Piston Balance High Volume

Part Description	Standard Material	Erosive Material	Corrosive Material
Body	Ductile (ASTM A395)		
Bonnet	Ductile (ASTM A395)		
Cylinder	303SS (ASTM A582)		316SS (ASTM A479)
Piston	303SS (ASTM A582)		316SS (ASTM A479)
Ratio Plug	303SS (ASTM A582)	D-2 (ASTM A681)	316SS (ASTM A479)
Removable Seat	303SS (ASTM A582)	D-2 (ASTM A681)	316SS (ASTM A479)
Stuffing Box	Ductile (ASTM A395)		
Stuffing Box Stem	17-4PH (ASTM A564)		316SS (ASTM A479)
Piston Stem	303SS (ASTM A582)		316SS (ASTM A479)
Seat Disc	316SS (ASTM A479)		

LIQUID DUMP VALVES PNEUMATIC OPERATED



CODE BUILDER D SERIES

Series:

D = Dump Valve

Model:

PD = Pneumatic Operated Diaphragm Balanced Fail Close
 PE = Pneumatic Operated Diaphragm Balanced Fail Open
 PP = Pneumatic Operated Piston Balanced Throttle Fail Close 4" only
 PQ = Pneumatic Operated Piston Balanced Throttle Fail Open 4" only

Line Size:

2 = 2 NPS
 3 = 3 NPS
 4 = 4 NPS
 6 = 6 NPS (PD ONLY)

End Connection:

SA = FNPT (2 & 3 NPS only)
 AR = 150RF

Body Type:

A = Angle
 T = Thru

Shell Material:

D = Ductile Iron
E = Ductile Iron w/Coating

Inner Valve Size:

F = Full Port
 R = Reduced Port (PP only)

Actuator:

P = Pneumatic

Service Type:

S = Standard
 C = Corrosive

D PD 2 SA A D F 1 S

Options: Additional cost and lead times will apply
 If multiple options required input in sequential order
 Leave blank if no options required

- 1 = NACE Certification (Corrosive Option Only)
- 2 = Hydrostatic Test Certification
- 3 = MTR (Shell Components)
- H = HSN Elastomers
- V = FKM Elastomers
- X = Export (Hydrostatic test, MTR & 3.1)

Not all selections available on all products listed.
 See product pages 04:10.1 - 04:10.7 & 04:30.1 - 04:40.7
 for available options