

APPLICATION:

Vent lines on oil separators, flow treaters, compressor stations, gas gathering systems.

OPERATION:

The Pilot Assembly and Motor Valve Stem Assembly (Crosshatched) are the only moving units in the regulator. The PILOT PLUG consists of two stainless balls rigidly connected together. The upper seat for the PILOT PLUG is the Motor Valve Diaphragm Pressure inlet (Red to Yellow). The lower seat for the PILOT PLUG is the pressure vent (Yellow to Atmosphere).





The PILOT SPRING in the bonnet loads the upper side of the Pilot Assembly and is opposed on the underside by Upstream Pressure (Red).

Assume the PILOT SPRING is compressed with the ADJUSTING SCREW for a set pressure greater than the Upstream Pressure (Red). The Pilot Assembly is forced downward by the PILOT SPRING. The lower seat for the PILOT PLUG (Yellow to Atmosphere) is closed and the upper seat for the PILOT PLUG (Red to Yellow) is open. This lets full Upstream Pressure (Red) load the motor valve. The area of the MOTOR VALVE DIAPHRAGM is twice the area of the motor valve seat, assuring a Class VI positive shut-off.

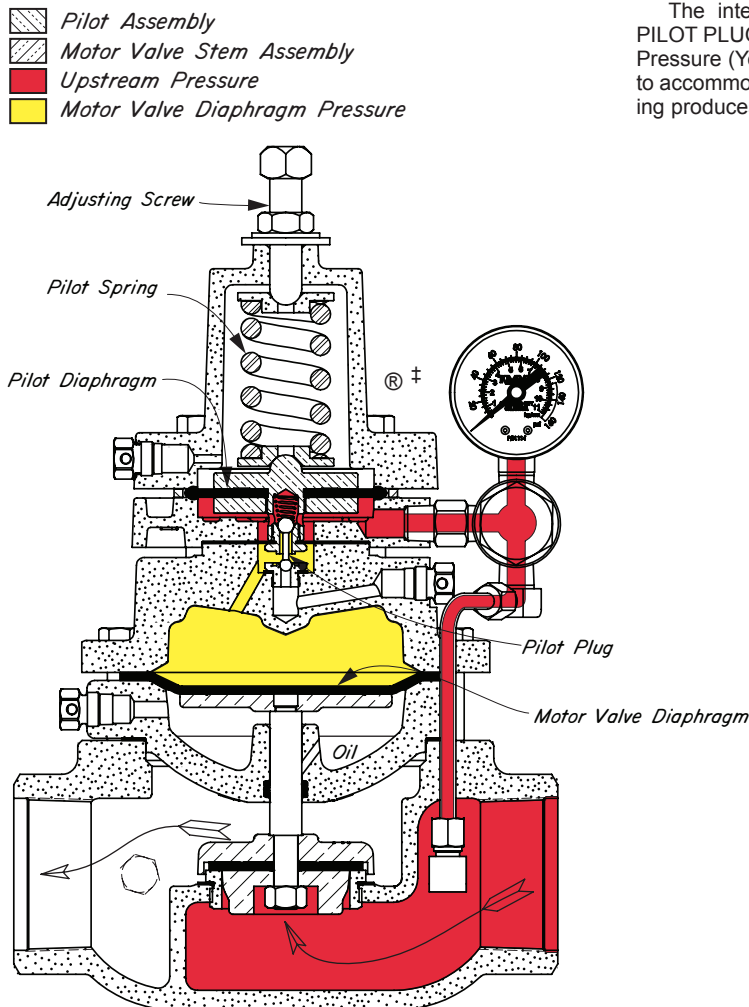
As the Upstream Pressure (Red) increases to the set pressure, the Pilot Assembly moves upward against the PILOT SPRING to first close the upper seat (Red to Yellow) and open the pressure vent (Yellow to Atmosphere). As the Motor Valve Diaphragm Pressure (Yellow) is decreased, the Upstream Pressure (Red) acting under the motor valve seat, opens the valve. With relief of Upstream Pressure (Red) through the motor valve, the Pilot Assembly assumes a position in which both seats of the PILOT PLUG are closed.

The intermittent vent pilot, three-way valve action of the PILOT PLUG against its seat adjusts the Motor Valve Diaphragm Pressure (Yellow), repositioning the Motor Valve Stem Assembly to accommodate any rate of flow. The rapid but stable repositioning produces a true throttling action.



-  Pilot Assembly
-  Motor Valve Stem Assembly
-  Upstream Pressure
-  Motor Valve Diaphragm Pressure



Kimray is an ISO 9001- certified manufacturer.

PRESSURE REGULATORS



GAS BACK PRESSURE WITH REDUCED INNER VALVE
 DUCTILE IRON 10-300 psig OPER. PRES.

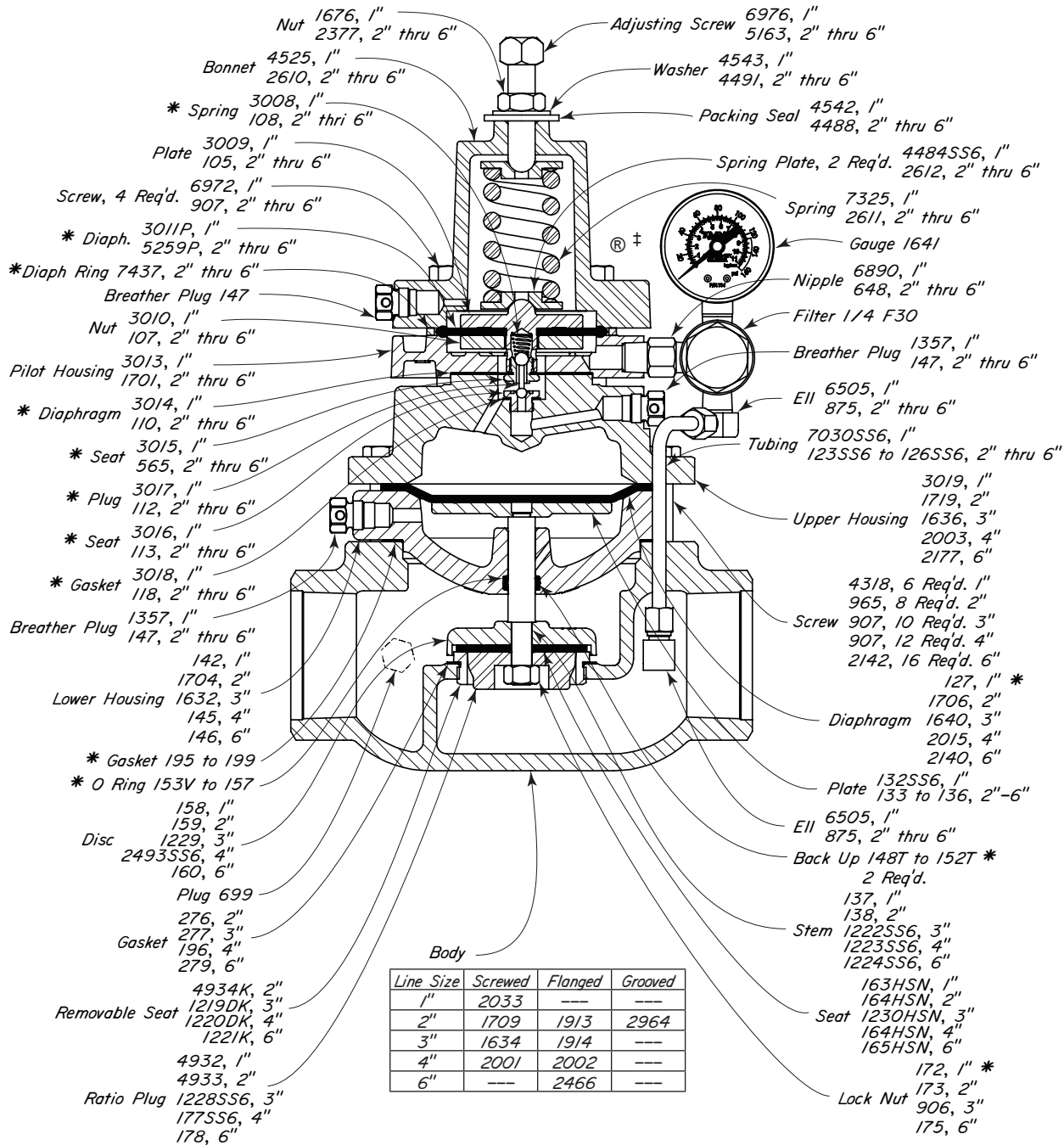

Line Size	Screwed	Flanged	Grooved
1"	2033	---	---
2"	1709	1913	2964
3"	1634	1914	---
4"	2001	2002	---
6"	---	2466	---

THRU VALVES AVAILABLE:

PART NO.	BODY [†] CONNECTION	MODEL NO.	OPER. PRES.	MAX ^{††} W.P.	REP. KIT
AKB5	1" NPT	130 SGT BP5	5-300	300	RRT
AAR5	2" NPT	230 SGT BP5	5-300	300	RAA
AAS5	2" 150RF	218 FGT BP5	5-250	250	RAA
AAQ5	2" GRVD.	230 GGT BP5	5-300	300	RAA
AAU5	3" 150RF	318 FGT BP5	5-250	250	RAB
AAX5	4" 150RF	418 FGT BP5	5-250	250	RAC
AAZ5	6" 150RF	618 FGT BP5	5-250	250	RAD

NOTES:

*These parts are recommended spare parts and are stocked as repair kits.
 The numbers of a series assigned to a part indicate different line sizes. For example: Stem 137-1", 138-2", 139-3", 140-4", 141-6".
 For standard & optional Seals, Metals, Cv values, Material specifications & Dimensions see Technical Data on pages A:1 - A:V
[†] Standard Trim size is same as connection size. for Reduced trim sizes, see A:1
^{††} Max W.P. valves based on -20°F to 100°F. See page A:V for temps above 100°F

Kimray is an ISO 9001- certified manufacturer.

Table 1 - Flow Coefficient(Cv) at % stem travel for Pilot Operated Regulators											
1" Pressure Regulator											
Trim Size in.(mm)	Cf	Valve Opening Percentage									
		10	20	30	40	50	60	70	80	90	100
1/2 in (12mm) Reduced	0.75	0.4	0.7	0.9	1.3	1.8	2.5	3.2	3.9	4.5	5
1 in (25mm) Full Port	0.74	1.1	1.8	2.4	3.4	4.8	6.6	8.5	10.2	11.9	13.2
2" Pressure Regulator											
Trim Size in. (mm)	Cf	Valve Opening Percentage									
		10	20	30	40	50	60	70	80	90	100
1 1/4 in (31 mm) Reduced	0.75	1.8	2.8	3.9	5.4	7.7	10.5	13.6	16.2	19.0	21.0
2 in Removable Full Port *	0.84	4.0	6.2	8.6	12.1	17.2	23.5	30.4	36.3	42.5	47.0
2 in (50 mm) Full Port *	0.75	4.4	6.9	9.5	13.4	19.1	26.0	33.6	40.2	47.0	52.0
3" Pressure Regulator											
Trim Size in. (mm)	Cf	Valve Opening Percentage									
		10	20	30	40	50	60	70	80	90	100
1 5/8 in (66 mm) Reduced	0.82	2.9	4.5	6.2	8.8	12.5	17.0	22.0	26.3	30.7	34.0
3 in (76 mm) Full Port	0.75	9.9	15.6	21.5	30.2	42.9	58.6	75.7	90.4	105.7	117.0
4" Pressure Regulator											
Trim Size in. (mm)	Cf	Valve Opening Percentage									
		10	20	30	40	50	60	70	80	90	100
2 in (50 mm) Reduced	0.80	4.7	7.3	10.1	14.2	20.2	27.5	35.6	42.5	49.7	55.0
4 in (100 mm) Full Port	0.75	17.8	27.9	38.6	54.2	77.0	105.2	135.9	162.2	189.8	210.0
6" Pressure Regulator											
Trim Size in. (mm)	Cf	Valve Opening Percentage									
		10	20	30	40	50	60	70	80	90	100
3 in (76 mm) Reduced	0.80	10.2	16.0	22.0	30.9	44.0	60.1	77.7	92.7	108.4	120.0
6 in (152 mm) Full Port	0.75	40.6	63.8	88.1	123.8	176.0	240.4	310.6	370.7	433.7	480.0

Kimray flow equations conform to ANSI/ISA - 75.01.01-2002

Kimray inherent flow characteristics conform to ANSI/ISA 75.11.01 -1985

* Use "2 inch Removable Full Port" values for regulators with operating pressure ranges of 10-250psig, 10-285psig & 10-300psig

PRESSURE REGULATORS



DIMENSIONS

FOR: BACK PRESSURE
UPSTREAM DIFFERENTIAL PRESSURE
PRESSURE REDUCING-BALANCED
PRESSURE REDUCING VACUUM

PRESSURE DIFFERENTIAL
PRESSURE REDUCING
BACK PRESSURE VACUUM
LIQUID BACK PRESSURE

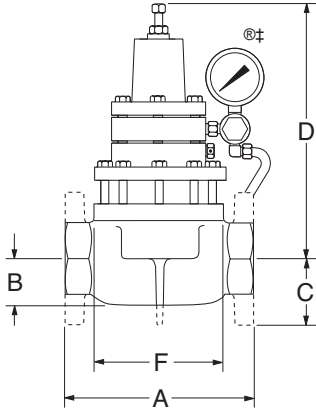

DUCTILE

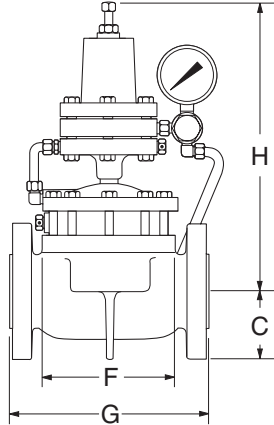

STEEL

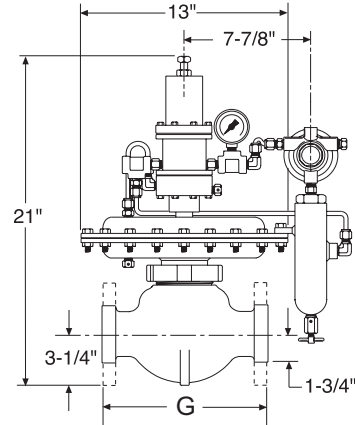

250 S/FGT-BP-S

FOR: LOW PRESSURE BACK PRESSURE
OUNCES BACK PRESSURE TO VACUUM
OUNCES PRESSURE REDUCING
OUNCES PRESSURE REDUCING VACUUM
VACUUM BACK PRESSURE TO VACUUM

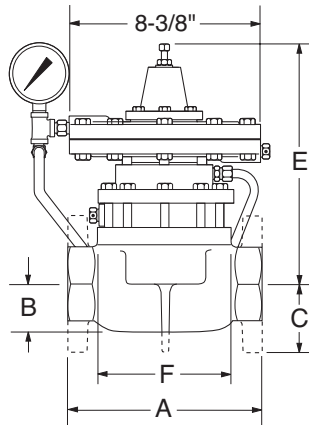

DUCTILE

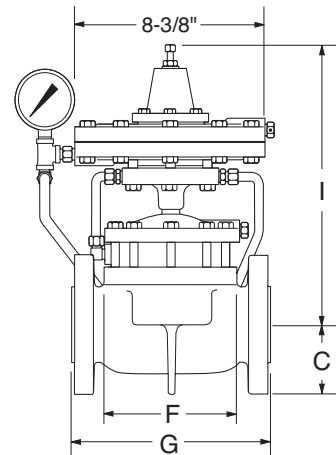

STEEL

LINE SIZE	BODY SIZE	A	B	C	D*	E	F	G	H*	I
1"	NPT	4 3/8"	1 1/8"		7 1/2"	11 5/8"	3 1/4"			
2"	NPT	8 1/2"	2 1/8"		11 1/2"	10 1/2"	6 1/2"			
	FLANGED	9"		3"	11 1/2"	10 1/2"	6 1/2"	9 1/8"	14 1/2"	14"
	GROOVED	8 3/4"	2 1/8"		11 1/2"	10 1/2"	6 1/2"			
250 S/FGT	NPT							10 1/2"		
	FLANGED							10 3/8"		
3"	NPT	12 1/16"	3 1/16"		13"	12"	8 1/2"			
	FLANGED	12 3/16"		3 3/4"	13"	12"	8 1/2"	12 3/8"	16 1/2"	15 1/2"
4"	NPT	15" 1/16"	4"		14 1/2"	13 3/16"	10 1/2"			
	FLANGED	15 1/16"		4 1/2"	14 1/2"	13 3/16"	10 1/2"	15 1/16"	18 1/2"	16 11/16"
6"	FLANGED	22"		5 1/2"	17"	17 7/8"	16"	21 15/16"	20 1/2"	18 3/8"

FLANGE DIMENSIONS ARE ANSI 125/150 STANDARD. *Add 7/8" to Pressure Reducing Balanced and Up Stream Differential Pressure Regulators for this dimension.

Part	Standard Material	Optional Material
Seat	Nitrile	FKM, HSN, AFLAS®, Gylon®
O-rings	Nitrile	FKM, HSN, AFLAS®, Gylon®
All Diaphragms Except Pilot Diaphragm	Nitrile	FKM, HSN, AFLAS®, Gylon®
Pilot Diaphragm	Polyurethane	FKM, HSN, AFLAS®, Gylon®

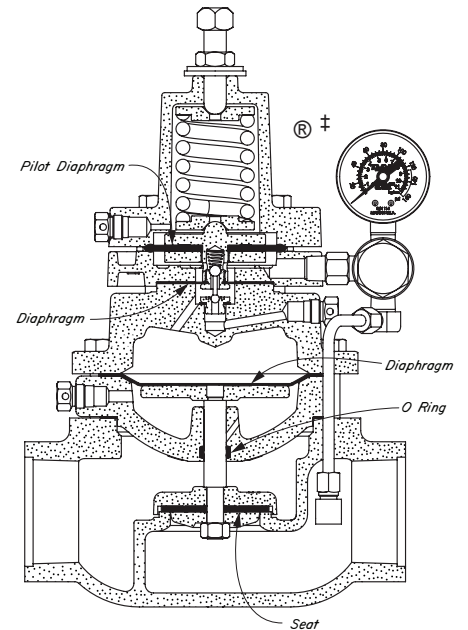

		NITRILE	HIGHLY SATURATED NITRILE	FKM	AFLAS®	POLY-URETHANE	GYLON
	Kimray Suffix	-	HSN	V	AF	P	GY
Resistance	Abrasion	G	G-E	G	G	E	E
	Acid	F	G-E	G-E	E	P	E
	Chemical	F	F	E	E	F	E
	Cold	G	G	P	P	G	E
	Flame	P	P	E	E	P	P
	Heat	G	E	E	E	F	E
	Oil	G-E	E	E	E	G	E
	Ozone	P	G	G-E	E	E	E
	Set	G	G	G-E	P	F	P
	Tear	F	F	F	P	G-E	E
	Water/Steam	F	E	P	G	P	E
	Weather	F	G	E	E	E	E
	CO2	F-G	G	G	G	G	E
	H2S	P	F	P	E	G	E
Methanol	F	E	P	P	P	E	
Properties	Dynamic	G	G	G	G	E	P
	Electrical	F	F	F	G-E	F	E
	Impermeability	G	G	G	G	G	E
	Tensile Strength	G	G-E	G	F	G-E	E
	Temp. Range (°F)	-20° to +225°F	-20° to +250°F	-15° to +400°F	+15° to +450°F	-40° to +180°F	-450° to +500°F
	Temp. Range (°C)	-29° to +107°C	-29° to +121°C	-26° to +204°C	-9° to +232°C	-40° to +82°C	-268° to +260°C
	Form	O,S,D	O,S,D	O,S,D	O,S,D	S,D	S,D

RATINGS: P-POOR, F-FAIR, G-GOOD, E-EXCELLENT

Table 4 - Materials of Construction

Part Description	Valve Size	Standard Material	Optional Material(s)
Ratio Plug	1" & 2"	316 Powdered Metal SS-316NI-25	N/A
	1" & 2" Reduced Trim	Steel, ASTM A-108	316 Stainless Steel ASTM A-479
	3"	Powdered Metal F-008	316 Stainless Steel ASTM A-479
	4" & 6"	Ductile, ASTM A-395	316 Stainless Steel ASTM A-479
Seat Disc	1"	Powdered Metal F-0008-30	316 Stainless Steel ASTM A-479
	2", 3" & 4"	Ductile, ASTM A-395	Stainless Steel ASTM A-351 CF8M
	6"	Ductile, ASTM A-395	Stainless Steel ASTM A-240
Stem	1" thru 6"	303 Stainless Steel, ASTM A-582	316 Stainless Steel ASTM A-479
Body	1" thru 6"	Ductile, ASTM A-395	N/A
Body	2" thru 6"	Steel, ASTM A-216 WCB	Stainless Steel ASTM A-351 CF8M
Tubing	175 W.P. or Less	Copper Tubing ASTM B-380 UNS C-12200	316 Stainless Steel ASTM A-213
		Copper Tubing ASTM B-280 UNS C-12200	316 Stainless Steel ASTM A-213
	Greater Than 175 W.P.	304 Stainless Steel ASTM A-249	316 Stainless Steel ASTM A-213
Removable Seat	2" thru 6" Ductile Body	Ductile, ASTM A-395	Stainless Steel ASTM A-351 CF8M
	2" thru 6" Steel Body	Stainless Steel ASTM A-351 CF8M	N/A

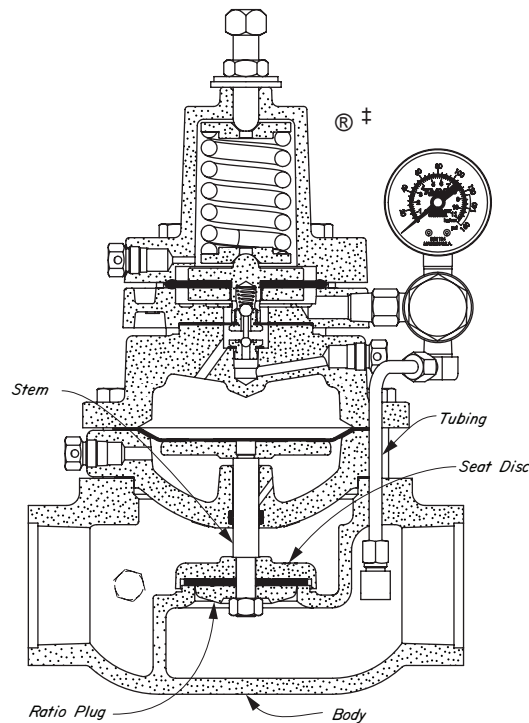
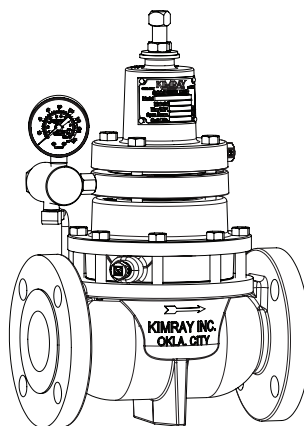
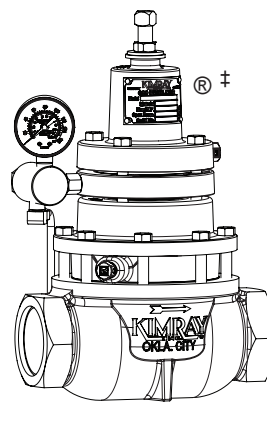

Table 6 - Temperature vs. Pressure Rating

ASTM Class Temperature °F (°C)	Flange Class
	150 RF
	Static Test Pressure (psig)
	450 (31 bar)
Maximum Allowable Non-Shock Pressure (psig)	
CAST DUCTILE ASTM A-395	
	Flange Class
	150 RF
-20 to 100 (-28 to 37)	250 (17.2 bar)
200 (93)	235 (16.2 bar)
300 (148)	215 (14.8 bar)
400 (204)	200 (13.7 bar)
500 (260)	170 (11.7 bar)
600 (315)	140 (9.6 bar)
650 (343)	125 (8.6 bar)
700 (371)	
CAST STEEL ASTM A-216 - WCB	
	Flange Class
	150 RF
-20 to 100 (-28 to 37)	285 (20.0 bar)
200 (93)	260 (17.9 bar)
300 (148)	230 (15.9 bar)
400 (204)	200 (13.8 bar)
500 (260)	170 (11.7 bar)
600 (315)	140 (9.7 bar)
650 (343)	125 (8.6 bar)
700 (371)	110 (7.6 bar)



FLANGED (150RF)



SCREWED (NPT)

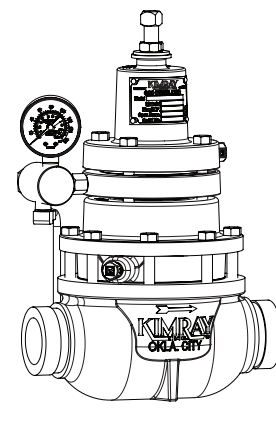

GROOVED

Kimray valves conform to ASME B16.34-2009 for working pressure vs working temperature & ASME B16.5-1996 for flanges and flanged fittings.