

### BELLOWS CONTROLLED HIGH PRESSURE MODEL BH

#### APPLICATION:

Pilot may be installed as Back Pressure Regulator with a Pressure Closing Motor Valve.

Pilot may be used as a Pressure Reducing Regulator with a Pressure Opening Motor Valve.

Pilot may be used as a pressure monitor that provides an output signal when the sense pressure falls below the set pressure, or when the signal goes above the set pressure.

#### FEATURES:





- Single Adjusting Screw
- Accurate control
- Proportional control
- Indirect or Direct Action
- Remote Installation

#### CLASSIFICATIONS:

- Non-Bleed / Intermittent Vent

#### CERTIFICATIONS:

- Canadian Registration Number (CRN):  
0C05370.24567890NTY

-  Pilot Diaphragm Assembly
-  Supply Pressure
-  Sense Pressure
-  Modulated Output Pressure

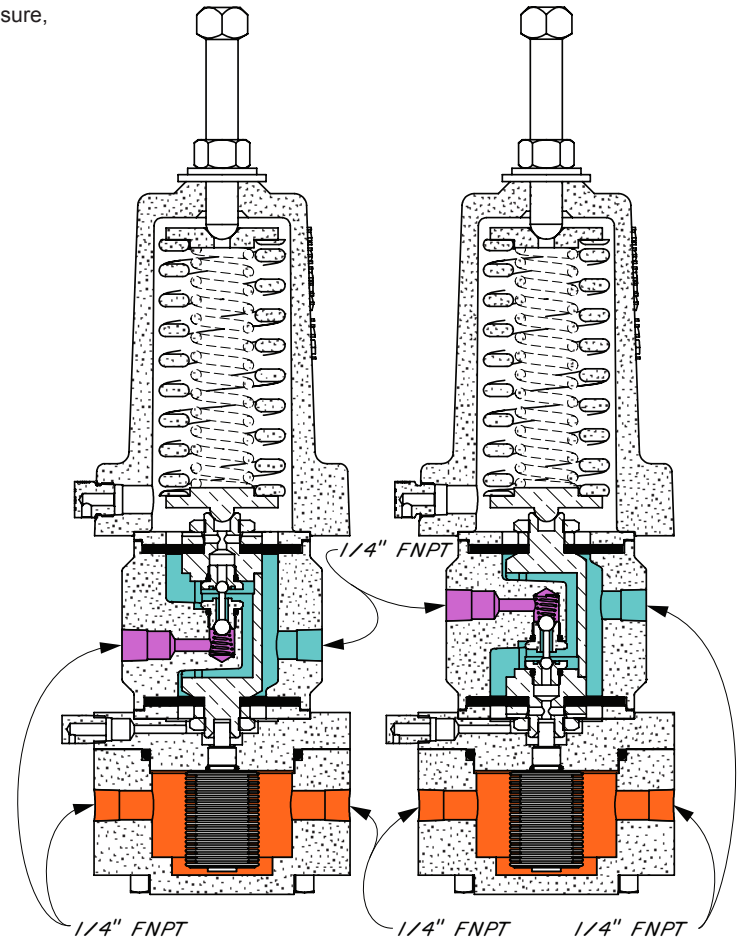

INDIRECT

DIRECT



Standard Configuration Code †	Order Code	Output Change per 1 psig Sense	Set Point Change per turn	Supply Press psig	Min. W.P. psig	Max. W.P. psig ††
PBHNW5S	AFZ2	1.6	20	5-30	75	750
PBHNW6S	AFZ	1	40	5-30	125	1500
PBHNW7S	AFZ7	0.75	60	5-30	200	2500
PBHDW5S	AFZ3	1.6	20	5-30	75	750
PBHDW6S	AFZ1	1	40	5-30	125	1500
PBHDW7S	AFZ6	0.75	60	5-30	200	2500

#### NOTES:

For standard & optional seals, metals, Cf Cv values, material specifications & dimensions see technical data on pages 09:I - 09:IV

† For Corrosive service remove last "S" & replace with "C"

† For code builder see page 09:00.2

†† Max W.P. values based on -20°F to 100°F.

BELLOWS CONTROLLED HIGH PRESSURE  
MODEL BH DRAWING

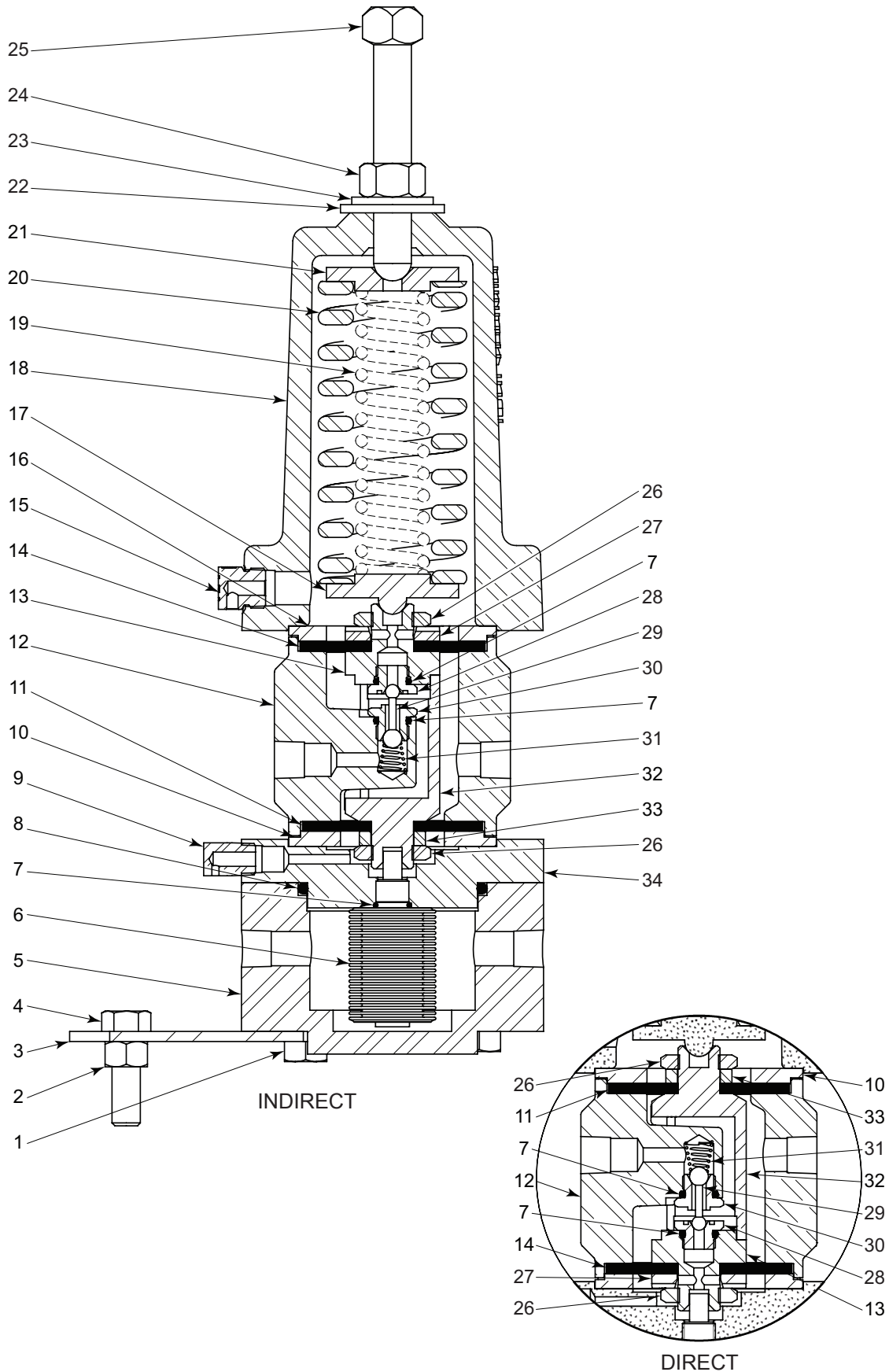

All Pictures shown are for illustration purpose only. Actual product may vary due to product enhancement.

ITEM	QTY.	DESCRIPTION	PART NO	
			STANDARD	CORROSIVE
1	4	Screw	4427	
2	2	Nut	241	
3	1	Mounting Bracket	4428	
4	2	Screw	430	
5	1	Main Body	4429	4429S6
6	1	Bellows Assembly	750 psig	5148
			1500 psig	4420
			2500 psig	6521
7	3	O-Ring *	265	265
8	1	O-Ring *	802	802
9	1	Breather Plug	1357	1357SS6
10	1	Diaphragm Plate	4434SS6	
11	1	Diaphragm *	4447	4447
12	1	Supply Body	4451	4451SS6
13	1	Seat Housing	4440	4440SS6
14	1	Diaphragm *	4436	4436
15	1	Breather Plug	147	147SS6
16	1	Diaphragm Plate	4441SS6	
17	1	Lower Spring Plate	4443SS6	
18	1	Bonnet	4450	
19	1	Spring (2500 psig Only)	6522	
20	1	Spring	4448	
21	1	Upper Spring Plate	4444	4444SS6
22	1	Packing Seal *	4488	
23	1	Washer *	4491	
24	1	Nut	2377	2377SS6
25	1	Adjusting Screw	4446	4446SS6
26	1	Diaphragm Nut	4433	4433SS6
27	1	Diaphragm Spacer	4442SS6	
28	1	Seat *	113	113SS6
29	1	Pilot Plug *	112	112
30	1	Seat *	565	565SS6
31	1	Spring *	108	108HAC
32	1	Stem	4435SS6	
33	1	Diaphragm Spacer	4432SS6	
34	1	Lower Housing	4431	4431SS6
Not Shown	Gauge	750 psig w.p.	7708	
		1500 psig w.p.	7709	
		2500 psig w.p.	7710	
Not Shown	Plug	699	699SS6	
	Repair Kit	RBQ	RBQV	

\* These parts are recommended spare parts and are stocked as repair kits.

CODE BUILDER  
P SERIES (PILOTS)

Series:

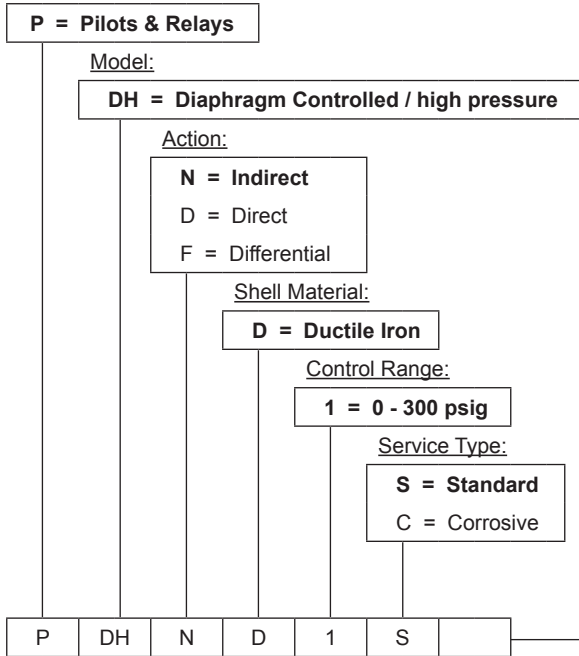

Not all selections available on all products listed.  
See product pages 01:10.1 - 01:10.6 for available options

Options: Additional cost and lead times will apply  
If multiple options required input in sequential order  
Leave blank if no options required

- 1 = NACE Certification (Corrosive Option Only)
- 2 = Hydrostatic Test Certification
- 3 = MTR (Shell Components)
- A = AFLAS Elastomer
- H = HSN Elastomer
- V = FKM Elastomer
- X = Export (Hydrostatic test, MTR & 3.1)

Series:

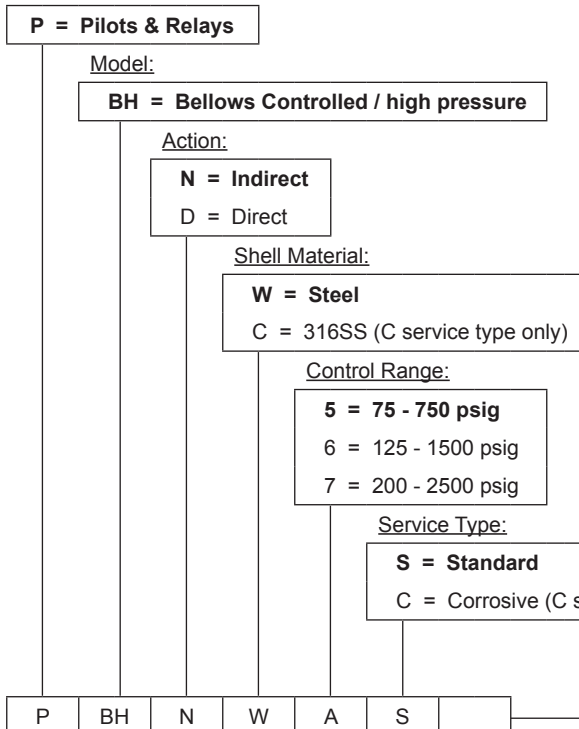

Not all selections available on all products listed.  
See product pages 01:20.1 - 01:20.3 for available options

Options: Additional cost and lead times will apply  
If multiple options required input in sequential order  
Leave blank if no options required

- 1 = NACE Certification (Corrosive Option Only)
- 2 = Hydrostatic Test Certification
- 3 = MTR (Shell Components)
- A = AFLAS Elastomer
- H = HSN Elastomer
- V = FKM Elastomer
- X = Export (Hydrostatic test, MTR & 3.1)

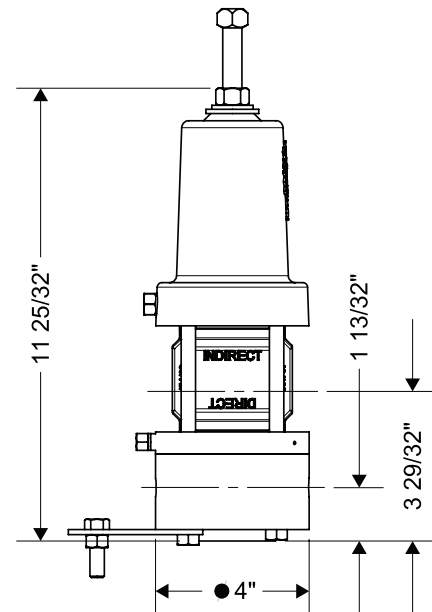
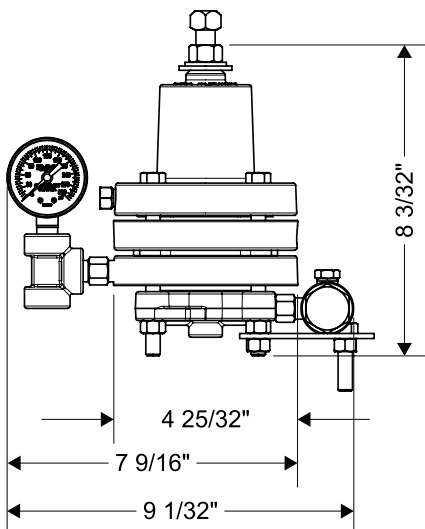
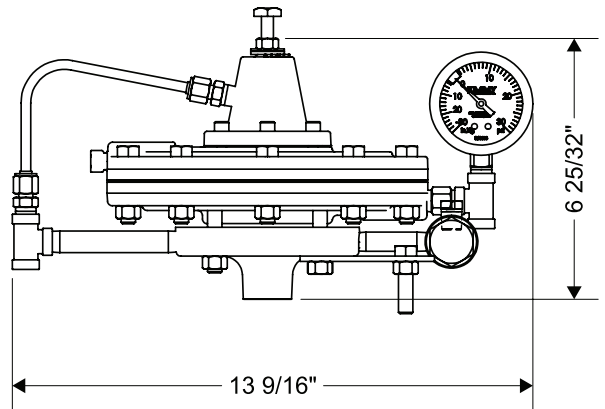
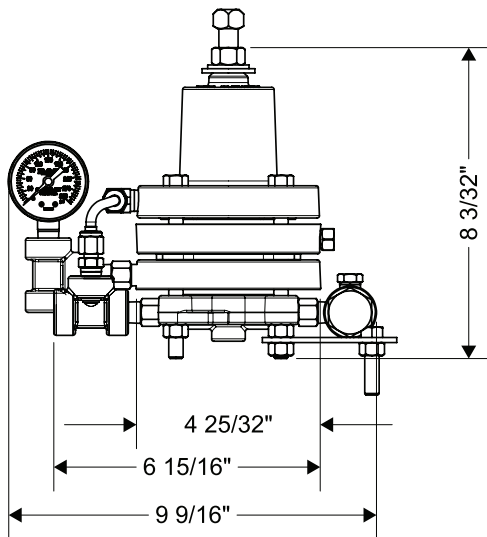
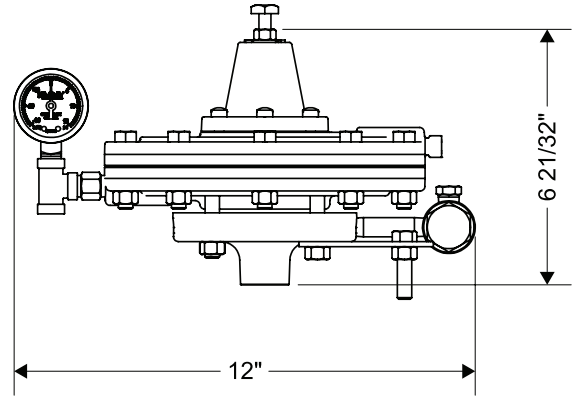
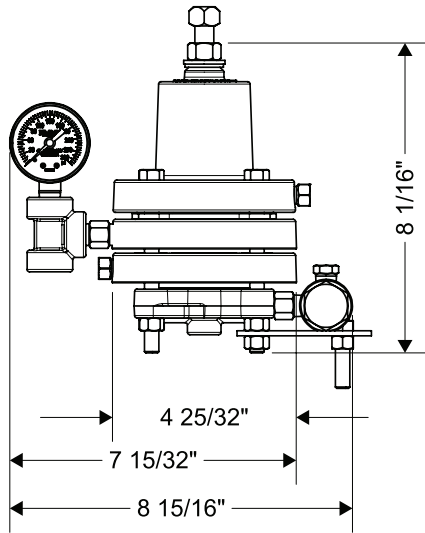

All Pictures shown are for illustration purpose only. Actual product may vary due to product enhancement.