

CERTIFICATIONS:

Canadian Registration Number (CRN):
 0F05370.2134567890NTY (External Float Cage)
 0H13594.2134567890NTY (Pneumatic Level Switch)
 NACE MR0175 compliant material: ASME SA-352-LCB
 Kimray is an ISO 9001- certified manufacturer.

ELECTRONIC

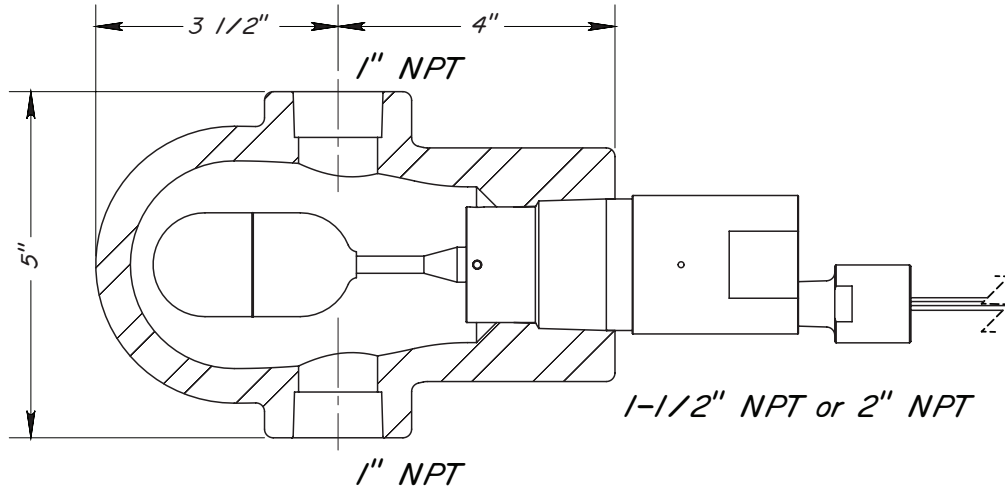

PNEUMATIC

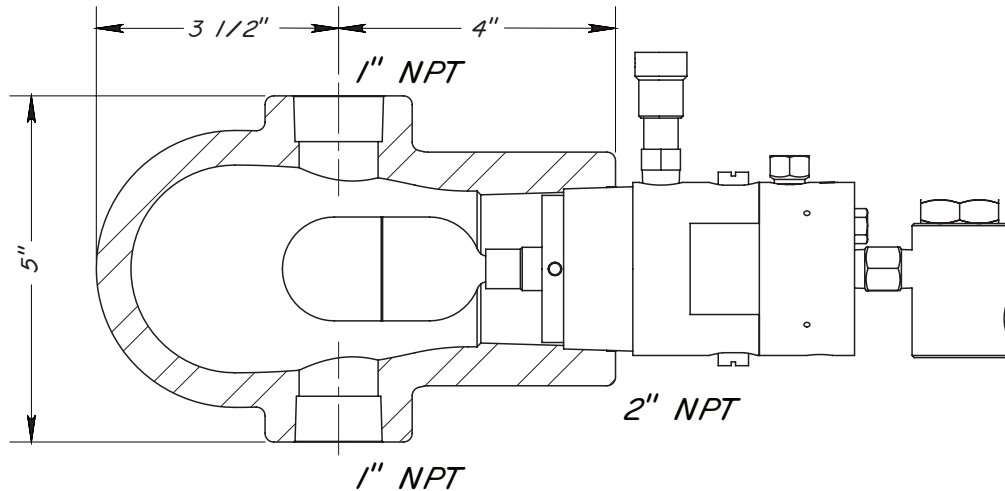

Part No.	Line Size	Connection Type	Temp Range	Max. W.P. ††
5522	1 1/2"	NPT	-50F - 500F	4000
5523	2"	NPT	-50F - 500F	4000

NOTES:

For standard & optional seals, metals, material specifications & dimensions see technical data on pages 08:1 - 08:VII

†† Max W.P. values based on -20°F to 100°F.