

APPLICATIONS:



Oil and gas separators, water knockouts, and similar equipment where a mechanical to pneumatic interface is required to operate motor valves.

FEATURES:

- Direct float operated
- Snap or throttle action
- Field reversible

CERTIFICATIONS:

Kimray is an ISO 9001- certified manufacturer.

 Diaphragm Assembly
 Supply Pressure
 Output Pressure

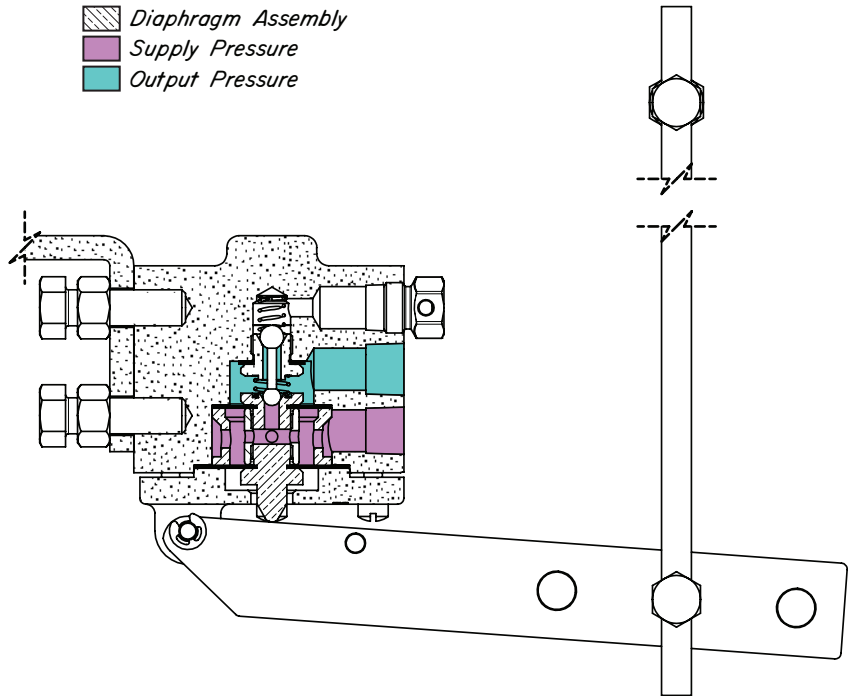

Float operated, 3 PM Pilot mounted on Kimray 8" Float Opening Cover.

Standard Order Code	Description	Supply Pressure psig	Output Pressure psig	Max. W.P. †† psig
CDA	3 PM	5 - 30	0 or Supply	30

NOTES:

For standard & optional seals, metals, Cf Cv values, material specifications & dimensions see technical data on pages 03:1 - 03:VI

†† Max W.P. values based on -20°F to 100°F.

LIQUID DUMP VALVES LEVER OPERATED

3 PM MECHANICAL PILOT

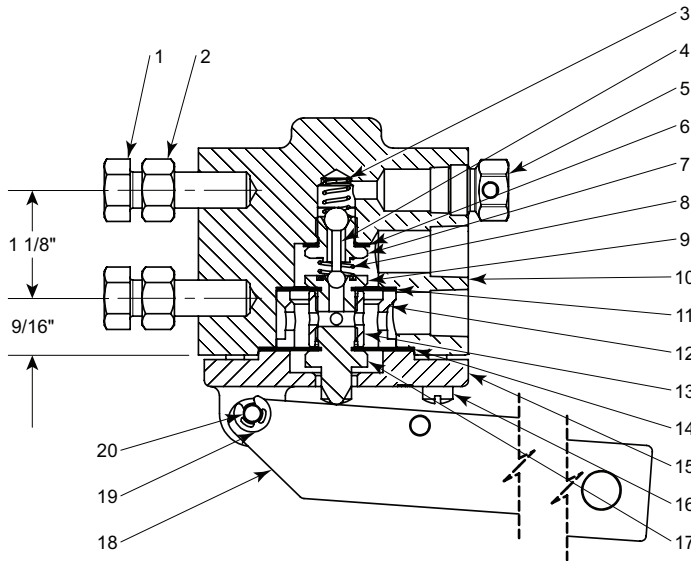

Adjustable Linkage (sold separately)

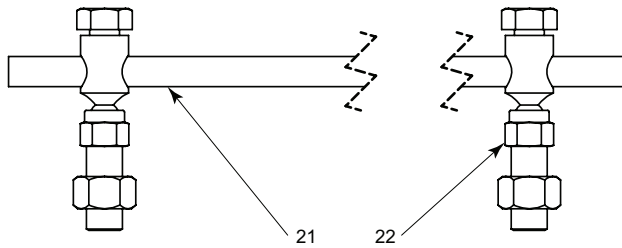

ITEM	QTY.	DESCRIPTION	PART NO.
1	2	3/8-16 Mounting Bolts	247
2	2	Nut	241
3	1	Spring	585L
4	1	Pilot Plug	112
5	1	Breather Plug	147
6	1	Gasket *	118
7	1	Seat	565
8	1	Spring	566
9	1	Seat	113
10	1	Body	592
11	1	Diaphragm *	584HSN
12	1	Spool	580
13	1	Spacer	581
14	1	Diaphragm *	583HSN
15	1	Cover	588
16	6	Screw	693
17	1	Button	590
18	1	Lever Bar	591
19	2	Snap Ring *	1181
20	1	Pin	589
Repair kit			RMN
* These parts are recommended spare parts & are stocked as repair kits.			
Adjustable Linkage (sold separately)			YTB
21	1	Rod	754
22	2	Ball joint	753

MOUNTING BRACKETS AVAILABLE	
Trunnion Description	Mounting Bracket
612 TO	903
812 TO	904
1012 TO	681
50 TOB-D	3035
25 TOB-D	3035
26 WA/26DM	1856

MECHANICAL PILOT INSTALLATION

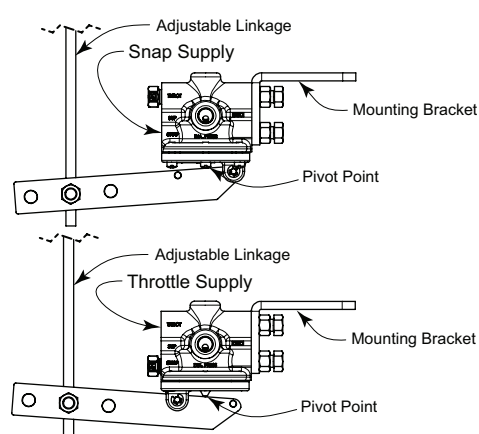
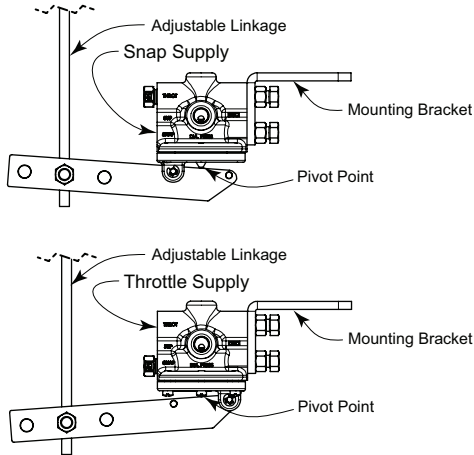

ROD MOVEMENT	OUTPUT
Up	Supply Pressure
Down	Vented

ROD MOVEMENT	OUTPUT
Up	Vented
Down	Supply Pressure

All Pictures shown are for illustration purpose only. Actual product may vary due to product enhancement.

Table 1 - Flow Coefficient(Cv) for Lever Operated Dump Valves													
Line Size	Trim Size in. (mm)	Trim Type	Cf	Valve Opening Percentage									
				10	20	30	40	50	60	70	80	90	100
LD - Diaphragm Balanced													
2"	1 1/2 in (38mm)	Linear (Nominal)	0.79	5.0	8.5	11.7	14.6	17.0	19.0	20.5	21.6	22.6	23.3
3"	2 1/4 in (57 mm)		0.79	6.7	11.1	15.6	20.3	24.8	29.2	33.4	37.2	40.7	43.8
4"	3 in (76 mm)		0.79	12.0	18.9	25.8	32.8	39.9	46.9	53.7	60.0	65.7	70.1
6"	4.88 in (124 mm)		0.79	14.2	21.0	31.6	61.2	98.3	139.0	179.7	217.6	250.2	277.0
LP - Piston Balanced Throttling													
2"	1 1/2 in (38mm)	Linear (Nominal)	0.75	3.5	5.0	7.4	9.6	11.8	13.9	16.2	18.4	20.4	22.7
	2 in (51 mm)		0.75	6.6	12.3	18.4	24.2	29.5	34.1	38.0	41.2	44.0	47.0
3"	3 in (76 mm)		0.75	12.7	18.7	29.0	41.0	52.9	63.4	71.9	78.4	83.7	89.0
LB - Piston Balanced													
2"	2 in (51 mm)	Linear (Nominal)	0.79	5.0	8.5	11.7	14.6	17.0	19.0	20.5	21.6	22.6	23.3
3"	3 in (76 mm)		0.79	6.7	11.1	15.6	20.3	24.8	29.2	33.4	37.2	40.7	43.8
4"	4 in (76 mm)		0.79	12.0	18.9	25.8	32.8	39.9	46.9	53.7	60.0	65.7	70.1

Kimray flow equations conform to ANSI/ISA - 75.01.01-2002
 Kimray inherent flow characteristics conform to ANSI/ISA 75.11.01 -1985

LIQUID DUMP VALVES LEVER OPERATED



DIMENSIONS TRUNNION ASSEMBLY

612, 812 & 1012 TO-D

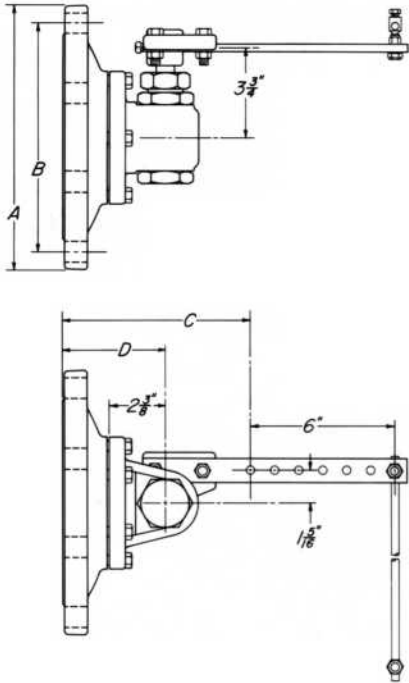

25 TOB

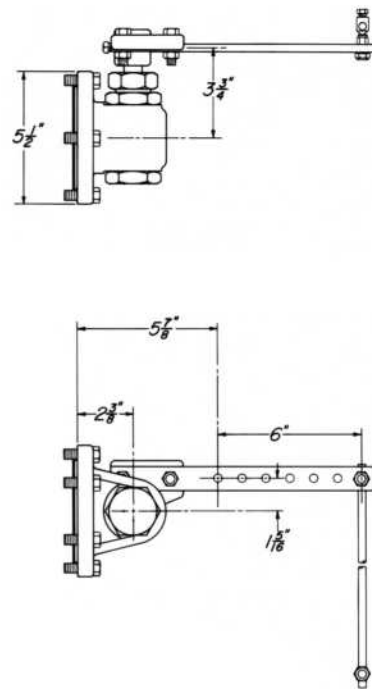

SIZE	NUMBER	A	B	C	D	No. SIZE OF BOLTS
6	612 TO	11 in	9 1/2 in	7 1/4 in	4 1/4 in	8 3/4 x 3 1/2
8	812 TO	13 1/2 in	11 3/4 in	7 1/4 in	4 1/4 in	8 3/4 x 3 1/2
10	6 1/8 in	16 in	14 1/4 in	7 1/2 in	4 1/2 in	12 7/8 x 3 1/2

All dimensions are in inches.

HUTA

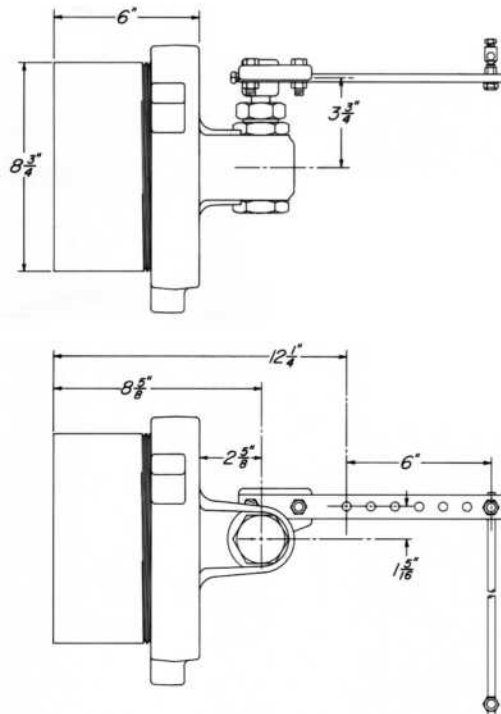

50 TOB-S

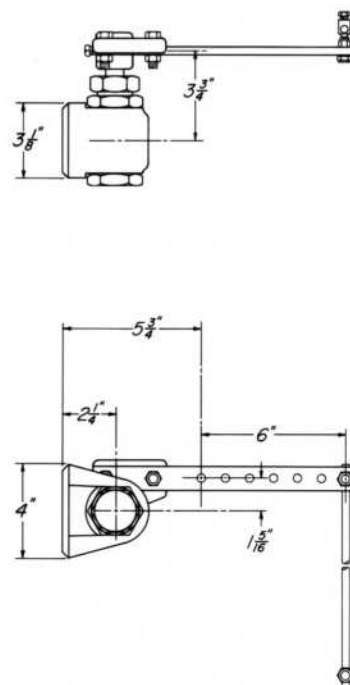

All Pictures shown are for illustration purpose only. Actual product may vary due to product enhancement.

Table 2 - Seal Options Dump Valves		
Part	Standard Material	Optional Material
O-rings	HSN	FKM
Diaphragm	HSN	FKM
Seat	HSN	FKM

Table 3 - Seal Options Trunnion Assemblies		
Part	Standard Material	Optional Material
O-rings	HSN	FKM

Table 4 - Seal Specifications			
		HIGHLY SATURATED NITRILE	FKM
Kimray Suffix		HSN	V
Resistance	Abrasion	G-E	G
	Acid	G-E	G-E
	Chemical	F	E
	Cold	G	P
	Flame	P	E
	Heat	E	E
	Oil	E	E
	Ozone	G	G-E
	Set	G	G-E
	Tear	F	F
	Water/Steam	E	P
	Weather	G	E
	CO2	G	G
	H2S	F	P
Methanol	E	P	
Properties	Dynamic	G	G
	Electrical	F	F
	Impermeability	G	G
	Tensile Strength	G-E	G
Temp. Range		-20° to +300°F	-15° to +400°F
		-29° to +149°C	-26° to +204°C
RATINGS: P-POOR, F-FAIR, G-GOOD, E-EXCELLENT			

Table 5 - Material Options Diaphragm Balanced Dump Valves		
Part Description	Standard Material	Corrosive Material
Body	Ductile (ASTM A395)	Ductile (ASTM A395) + Kimcoat
Ratio Plug	2 & 3 inch Delrin (ASTM D4181), 4 & 6 inch Ductile (ASTM A395)	316SS (ASTM A351)
Cage	2 & 3 inch Delrin (ASTM D4181), 4 & 6 inch Ductile (ASTM A395)	316SS (ASTM A351)
Stuffing Box	2 & 3 inch 303SS (ASTM A582), 4 & 6 inch Brass (ASTM B-16)	316SS (ASTM A479)
Bonnet	Ductile (ASTM A395)	Ductile (ASTM A395) + Kimcoat
Seat Disc	4 & 6 inch Ductile (ASTM A395)	4 inch 316SS (ASTM A351)
Stem	2, 3 & 4 inch 303SS (ASTM A582), 6 inch 316SS (ASTM A213)	316SS (ASTM A351)

Table 6 - Material Options Piston Balanced Throttling Dump Valves		
Part Description	Standard Material	Corrosive Material
Body	Ductile (ASTM A395)	Ductile (ASTM A395) + Kimcoat
Ratio Plug Full Port	2 inch 316 Powder Metal (ASTM 316-N1-25), 3 inch Powder Metal (F-008)	316 Powder Metal (ASTM 316-N1-25)
Stuffing Box	303SS (ASTM A582)	316SS (ASTM A479)
Bonnet	Ductile (ASTM A395)	Ductile (ASTM A395) + Kimcoat
Stem	303SS (ASTM A582)	316SS (ASTM A484)
Piston	2 inch 316SS (ASTM A484) , 2 inch reduced & 3 inch 303SS (ASTM A582)	316SS (ASTM A484)
Cylinder	303SS (ASTM A582)	316SS (ASTM A484)

Table 7 - Material Options Piston Balanced Dump Valves		
Part Description	Standard Material	Corrosive Material
Body	Ductile (ASTM A395)	Ductile (ASTM A395) + Kimcoat
Ratio Plug	2 & 3 inch Delrin (ASTM D4181), 4 inch Ductile (ASTM A395)	316SS (ASTM A351)
Cage	Ductile (ASTM A395)	316SS (ASTM A351)
Stuffing Box	2 & 3 inch 303SS (ASTM A582), 4 inch Brass (ASTM B-16)	316SS (ASTM A479)
Bonnet	Ductile (ASTM A395)	Ductile (ASTM A395) + Kimcoat
Seat Disc	4 inch Ductile (ASTM A395)	4 inch 316SS (ASTM A351)
Stem	303SS (ASTM A582)	316SS (ASTM A479)
Piston	316SS (ASTM A351)	316SS (ASTM A351)
Cylinder	2 & 3 inch 303SS (ASTM A582), 4 inch 316SS (ASTM A351)	316SS (ASTM A249)

Table 8 - Material Options Trunnion Assemblies		
Part Description	Standard Material	Corrosive Material
Bonnet	Ductile (ASTM A395)	
Plate	Steel SA515 Grade 70 Plate	
Stuffing Box	Brass B-16 C-36000 HO2	316SS (ASTM A479)
Union Nut	Ductile (ASTM A395)	
Weld Neck	Schedule 100 Pipe ASTM A-106 grade C	

LIQUID DUMP VALVES LEVER OPERATED



CODE BUILDER D SERIES

Series:

D = Dump Valve

Model:

LD = Lever Operated Diaphragm Balanced
 LP = Lever Operated Piston Balanced Throttle (2 & 3 inch only)
 LB = Lever Operated Piston Balanced

Line Size:

2 = 2 NPS
 3 = 3 NPS
 4 = 4 NPS
 6 = 6 NPS

End Connection:

SA = FNPT (2 & 3 NPS only)
 AR = 150RF

Body Type:

A = Angle
 T = Thru

Shell Material:

D = Ductile Iron
E = Ductile Iron w/Coating

Inner Valve Size:

F = Full Port
 R = Reduced Port (LP only)

Actuator:

L = Lever Operated

Service Type:

S = Standard
 C = Corrosive

D LD 2 SA A D F L S

Options: Additional cost and lead times will apply
 If multiple options required input in sequential order
 Leave blank if no options required

1 = NACE Certification (Corrosive Option Only)
 2 = Hydrostatic Test Certification
 3 = MTR (Shell Components)
 H = HSN Elastomers
 V = FKM Elastomers
 X = Export (Hydrostatic test, MTR & 3.1)

Not all selections available on all products listed.
 See product pages 03:10.1 - 03:20.7 for available options