

Valvcon™ electric actuator with sealed lead acid battery back-up power Series ADC

Valmet is a leading designer and provider of Valvcon™ compact, reliable, electronically controlled electric actuators for valves and dampers. We offer a complete line of electric actuators for accurate positioning of dampers and valves in the aerospace, automotive, consumer services, discrete manufacturing, energy, environmental, oil/ pipeline, petrochemical, power/ utilities, process, recreation, transportation, and water/ wastewater industries.

We have developed and introduced the industry's most innovative Valvcon™ electric actuator products, including simple "set and go" calibration, intelligent processor-based digital electronics, "Plug-in" accessory boards, Back-Up Power actuators, as well as electric actuators designed for remote control, solar-powered applications and two-wire network applications.

Specifications

The quarter-turn electric actuator complies with Part 15, Class A of the FCC regulations for emissions and conducted radiation for industrial devices. It meets NEMA standards for use in weathertight or weathertight and hazardous locations. The actuator is a single, complete unit composed of a compact cast aluminum housing, motor, gearing, limit switches controlled by metal cams for end of travel control, mechanical position indicator, and an optional internal back-up power source to drive to a pre-set position in the event of an external power loss. Actuator mounting flanges comply with ISO 5211 standards incorporating a female drive for direct output coupling. The actuator is capable of operating in ambient environments of -40°F to 130°F / -40°C to 55°C.



Features and benefits

Isolation and electrical

Internal electronic control board has clearly marked connection terminals for Power and Control Signals to prevent incorrect wiring and provides CW and CCW push buttons for local manual control. The actuator control electronics are electrically isolated to allow multiple actuators to be wired in parallel. Electronic control board is protected on the outward side with an insulating overlay providing terminal locations and additional safety. Additionally, the electronic control board includes a simple user-interface, consisting of slide switches and selection pots for mode selection, calibration, and set up. The electronic control board supplies a 4-20mA or 0-10VDC position

feedback signal, includes a holding brake feature to prevent back-driving, a heater and thermostat for low-temperature or high-humidity applications, and two auxiliary limit switches for indication. All internal connections, (motor leads, limit switch leads, etc.) are coded, using different style connectors for each function, to prevent incorrect wiring. All connections plug-in to simplify field repairs and upgrades. In AC line applications a highly reliable switching power supply provides power conversion to drive the internal brushless DC motor; in low-voltage applications the board provides the necessary conversion to drive the motor. Other than periodic replacement of the back-up battery; no maintenance is required.

Motor

The brushless DC motor is capable of running continuously at full torque at ambient temperature at or below 104°F / 40°C. Rated for 120 starts/minute.

Lubrication

All rotating power train components are coated with a multi-purpose grease. Lubricants are suitable for ambient conditions of -40°F to 130°F / -40°C to 55°C.

Gearing

The powertrain is comprised of hardened steel, machine cut spur gears. Non-metallic, aluminum, cast or stamped gearing is not used.

Limit switches

Actuators have two single pole double throw end-of-travel switches, rated for 11 amps at 250 VAC. During normal, (Smart Limit) operation the end-of-travel limit switches will not be activated; activating the limit switches will interrupt actuator travel. If utilizing the Cam Limit type, the end-of-travel cams will define the full CW and full CCW stop positions. Two additional SPDT limit switches are included for position indication purposes. The auxiliary switches are fully adjustable to operate at any position, as required by the process application, providing end-of-travel indication.

On/Off Control (Open/Close Operation) or Proportional Control (Modulating Operation) with Battery Back-Up

The actuator can be configured for either On/Off or Modulating operation.

On/Off Control (Open/Close Operation):

ADC-Series actuators can be configured for Open/Close operation requiring separate Power and Control signals. The Power signal must be constantly maintained; The Control signal consists of one to three maintained AC or DC contacts and the actuator can be set to operate in Two-wire, Three-wire or Three-position modes. In Two-wire CW mode a signal is maintained to drive the actuator to the CW position and removed to drive to the CCW position. In Two-wire CCW mode a signal is maintained to drive the actuator to the CCW position and removed to drive to the CW position. In Three-wire mode separate Control

signals are applied to drive the actuator to the CW and CCW positions and may be removed at any point in mid-stroke to position the valve or damper. Three-wire mode also provides “latching” operation, whereby application of a momentary signal will drive the actuator to the respective end-of-travel position; the signal does not need to be maintained. Three-wire mode may be configured for Three-position operation, whereby separate Control signals are applied to drive the actuator to the CW, “MID” or CCW positions and may be removed at any point in mid-stroke to position the valve or damper.

Position control (modulating operation):

ADC-Series actuators can be configured for Modulating operation in which they will accept a variable, proportional 4-20mA or 0-10VDC valve position signal and respond by positioning the valve proportionately with an accuracy of 1%. Normally, the actuator drives clockwise in response to a decreasing control signal; however, the actuator is capable of “reverse acting” operation (driving counterclockwise in response to a decreasing control signal) without internal wiring changes. The actuator also accepts a resistance valve position signal, i.e. 0-135 Ohms, directly with simple board configuration adjustments. The actuator also provides the ability to adjust the sensitivity to control signal changes. Slide switches enable the user to set the actuator response to a loss of control signal, select the “fail” position upon loss of Power and select either the single cycle or multi-cycle loss of power mode. Locked rotor, stall protection initiates whenever the actuator is unable to achieve the position commanded by the control signal, and terminates power to the motor in order to prevent damage due to prolonged/repeated stall conditions.

Internal battery back-up

With the internal battery back-up feature, immediately upon loss of the Power signal, the internal battery will drive the actuator to the Power Fail Position. The Power Fail Position may be either the full CW, the full CCW or “MID” position and is determined by the Power Fail Position selection pot.

Breakaway torque

Designed for efficiency and reliability, all Valvcon™ actuators deliver the power you need when and where it is needed. With efficient gear trains and motors these actuators are rated at breakaway torque. Immediately upon power up, the actuator supplies the rated torque — when it is needed to break the valve away from its seat. Other manufacturer’s actuators may be rated at running torque, but actually deliver significantly less breakaway torque.

ADC-SERIES ENCLOSURES (150-600 LB-IN)

Mounting Flange, ISO 5211 F05 / F07

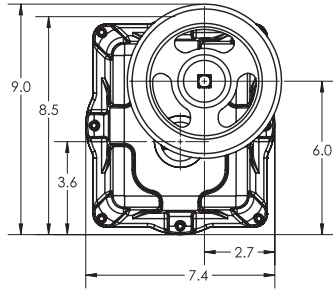

4 X M6-1.0 ∇ 0.75 MIN.
ON 1.969" B.C.

4 X M8-1.25 ∇ 0.75 MIN.
ON \varnothing 2.756" B.C.

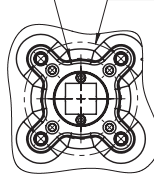

Female Square Drive

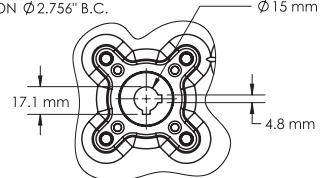

Female Keyed Drive

Actuator Size	Drive Option	Drive Type	Drive Size	Depth
150-600 lb-in (12-50 lb-ft; 17-68 Nm)	Standard	Square	0.750 (19mm)	0.90 (22.9mm)
150-600 lb-in (12-50 lb-ft; 17-68 Nm)	Option "I1"	Double Square	0.551 (14mm)	0.90 (22.9mm)
150-600 lb-in (12-50 lb-ft; 17-68 Nm)	Option "I2"	Square	0.669 (17mm)	0.90 (22.9mm)
150-600 lb-in (12-50 lb-ft; 17-68 Nm)	Option "Y1"	Keyed	0.591 (15mm)	1.40 (35.6mm)
150-600 lb-in (12-50 lb-ft; 17-68 Nm)	Option "Y2"	Keyed	0.787 (20mm)	1.40 (35.6mm)

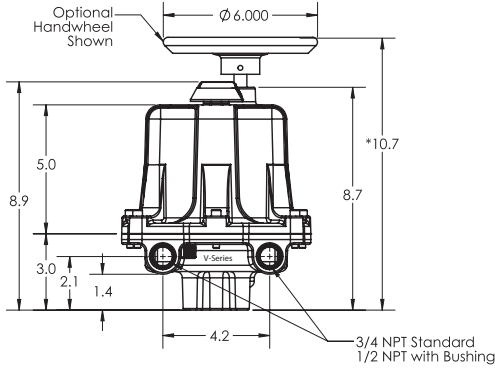

*9.7 WITHOUT HANDWHEEL
TO REMOVE COVER REQUIRES AN ADDITIONAL 4.75"

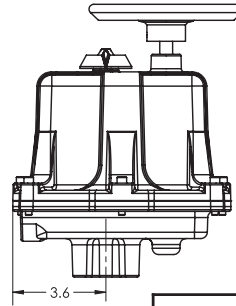

Approximate Weight	17 lb / 8 kg
---------------------------	--------------

All Dimensions in inches unless otherwise stated

ADC-SERIES ENCLOSURES (1000-3000 LB-IN)

Mounting Flange, ISO 5211 F07 / F10

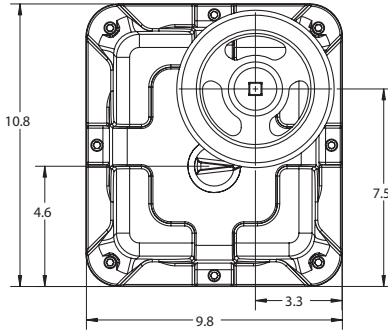

4 X M8-1.25 ∇ 0.75" MIN.
ON \varnothing 2.756" B.C.

4 X M10-1.5 ∇ 0.75" MIN.
ON \varnothing 4.016" B.C.

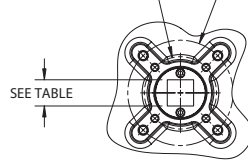

Female Square Drive

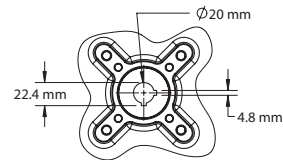

Female Keyed Drive

Actuator Size	Drive Option	Drive Type	Drive Size	Depth
1000-3000 lb-in (83-250 lb-ft; 113-339 Nm)	Standard	Square	1.000 (25mm)	1.20 (30.5mm)
1000-3000 lb-in (83-250 lb-ft; 113-339 Nm)	Option "I2"	Double Square	0.669 (17mm)	1.20 (30.5mm)
1000-3000 lb-in (83-250 lb-ft; 113-339 Nm)	Option "I3"	Double Square	0.748 (19mm)	1.20 (30.5mm)
1000-3000 lb-in (83-250 lb-ft; 113-339 Nm)	Option "I4"	Double Square	0.866 (22mm)	1.20 (30.5mm)
1000-3000 lb-in (83-250 lb-ft; 113-339 Nm)	Option "Y2"	Keyed	0.787 (20mm)	1.50 (38.1mm)
1000-3000 lb-in (83-250 lb-ft; 113-339 Nm)	Option "Y3"	Keyed	0.984 (25mm)	1.50 (38.1mm)

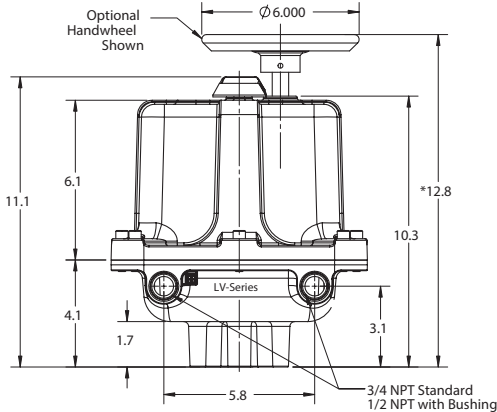

*11.7 WITHOUT HANDWHEEL
TO REMOVE COVER REQUIRES AN ADDITIONAL 5.75"

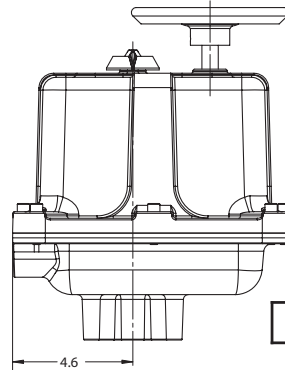

Approximate Weight	31 lb / 14 kg
---------------------------	---------------

All Dimensions in inches unless otherwise stated

ADC-series features at a glance!

- Universal Input Power – Actuator accepts 24/115/230AC and 12/24DC
- Universal Control – On/Off or Modulating from the same package
- Included Heater/Thermostat Feature – Can be enabled for “low-temp” use, “humidity control” use, or disabled to reduce power consumption.
- Internal battery packs allow for continued operation during power outages, provided the control signal remains.
- Field-settable for “fail clockwise” or “fail counter-clockwise”, or “fail” to a mid-travel position.
- CSA (C US) Certification
- Proven technology provides internal battery back-up capabilities within the standard size actuator enclosures
- Dual conduit openings make wiring easier, and keep power and control wiring separate.
- Replacement battery is commercially available (it is recommended that the battery is replaced every two years).
- Two year warranty.



ADC-series specifications

Battery back-up power

Valvcon™ ADC-Series electric actuators, equipped with internal battery power, allow you to shut down your system in the event of an external power loss. Engineered to supply dependable valve actuation, they can provide up to 10 complete cycles under their own internal power.

The electronic back-up powered feature incorporates a rechargeable battery pack that plugs right in to the PC board under the actuator cover. Upon power loss, the battery pack is automatically activated as the main power supply. The battery is compact and fits easily into the standard enclosures for an easy, space-saving upgrade. No hard-

wiring or other complex operations are required. Valvcon™ ADC-Series battery back-up actuators can be configured for continuous-duty on/off (open/close) or modulating operation.

- Internal battery allows for continued cycling during power outages, enabling an orderly shut-down of critical processes.
- A built-in trickle charger, with over-charge protection, ensures the battery always has enough power when called upon.
- Battery can be easily replaced in the field and is widely available.

ADC-series data

Torque Output (lb-in; lb-ft; Nm)	Duty Cycle (at/ below 104°F/ 40°C)	Duty Cycle (at max temp; 130°F/ 55°C)	12VDC			24VDC			24VAC			115VAC			230VAC		
			Cycle Time (sec /90°)	Time ON / OFF at max. temp. Current Draw (Amps)	Current Draw	Cycle Time (sec /90°)	Time ON / OFF at max. temp. Current Draw (Amps)	Current Draw	Cycle Time (sec /90°)	Time ON / OFF at max. temp. Current Draw (Amps)	Current Draw	Cycle Time (sec /90°)	Time ON / OFF at max. temp. Current Draw (Amps)	Current Draw	Cycle Time (sec /90°)	Time ON / OFF at max. temp. Current Draw (Amps)	Current Draw
			(sec /90°)	(sec)	(Amps)	(sec /90°)	(sec)	(Amps)	(sec /90°)	(sec)	(Amps)	(sec /90°)	(sec)	(Amps)	(sec /90°)	(sec)	(Amps)
150; 12; 17	100%	75%	11	11 / 4	2.2	13	13 / 5	1.2	8	8 / 3	1.8	9	9 / 3	0.4	9	9 / 3	0.4
300; 25; 34	100%	75%	17	17 / 6	2.5	13	13 / 5	1.4	12	12 / 4	2.1	13	13 / 5	0.5	13	13 / 5	0.4
600; 50; 68	100%	75%	17	17 / 6	2.8	13	13 / 5	1.7	13	13 / 5	2.5	14	14 / 5	0.6	14	14 / 5	0.5
1000; 83; 113	100%	75%	21	21 / 7	4	14	14 / 5	2.4	15	15 / 5	3.5	15	15 / 5	0.9	15	15 / 5	0.6
1500; 125; 169	100%	75%	40	40 / 14	4	24	24 / 8	2.4	27	27 / 9	3.5	29	29 / 10	0.9	29	29 / 10	0.6
2000; 167; 226	100%	75%	40	40 / 14	4.3	33	33 / 11	2.4	28	28 / 10	3.5	29	29 / 10	0.9	29	29 / 10	0.6
2500; 208; 282	100%	75%	55	55 / 19	3.3	40	40 / 14	2	38	38 / 13	3.1	39	39 / 13	0.8	39	39 / 13	0.6
3000; 250; 339	100%	75%	60	60 / 20	3.7	42	42 / 14	2.2	40	40 / 14	3.5	42	42 / 14	0.8	43	43 / 15	0.6

ADC-series electric actuators standard features

Heater/thermostat

The Heater/Thermostat option can be activated by a selection potentiometer on the board. The feature can be set for low-temperature, humidity control, or turned off completely to reduce power consumption.

Auxiliary limit switches

Two additional limit switches are included for position indication or as dry contacts to operate other devices. Single pole, double throw switches rated for 11A 1/2HP 250VAC, CSA certified.

ADC-series electric actuators options

(Order codes I1, I2, I3, and I4) ISO 5211 metric output

The actuator is equipped with an ISO 5211 compliant mounting configuration.

The standard drive output for 150-600 lb-in models is a 3/4" female square. The standard drive output for 1000-3000 lb-in models is a 1" female square. We offer several female metric drive output options, consult the "How to Order" section for available sizes for a given actuator model.

(Order codes Y1, Y2, and Y3) keyed output

The actuator is equipped with an ISO 5211 compliant mounting configuration.

The standard drive output for 150-600 lb-in models is a 3/4" female square. The standard drive output for 1000-3000 lb-in models is a 1" female square. We offer several female keyed drive output options, consult the "How to Order" section for available sizes for a given actuator model.

MODBUS® Communication

(Order code MB)

The Modbus option allows for controlling, and polling the unit for diagnostic information using a Modbus communication signal; RS-485, Two-Wire (Note: a Two-Wire crosscable connection may cause damage).

Handwheel override

(Order code Z)

For manual operation when power is not available. The handwheel is disengaged from the geartrain and does not turn during normal operation. When the handwheel is pushed down, it disengages the motor from the geartrain and allows manual operation.

Hazardous location enclosures

(ADCWX and LADCWX)

The standard enclosures (ADCW and LADCW) are rated for NEMA 4/4X (weather tight and corrosion resistant). The Hazardous Location enclosures (ADCWX and LADCWX) are Certified by CSA to meet NEMA 4/4X/7 & 9, Class I, Div 1, Groups C&D; Class II, Div. 1, Groups E, F, & G; Class III.

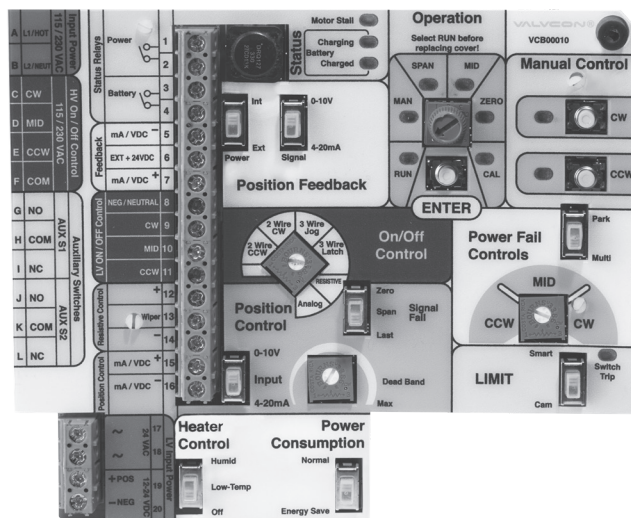

Modbus is registered trademark of Schneider Electric USA, Inc.

On / Off (2 Wire and 3 Wire) Control Wiring

Note: Both High Voltage and Low Voltage Input Power connections shown, **CONNECT ONLY ONE** input voltage

Note: Both High Voltage and Low Voltage Control Inputs are shown, connect for 2 Wire or 3 Wire Control as needed for desired application.

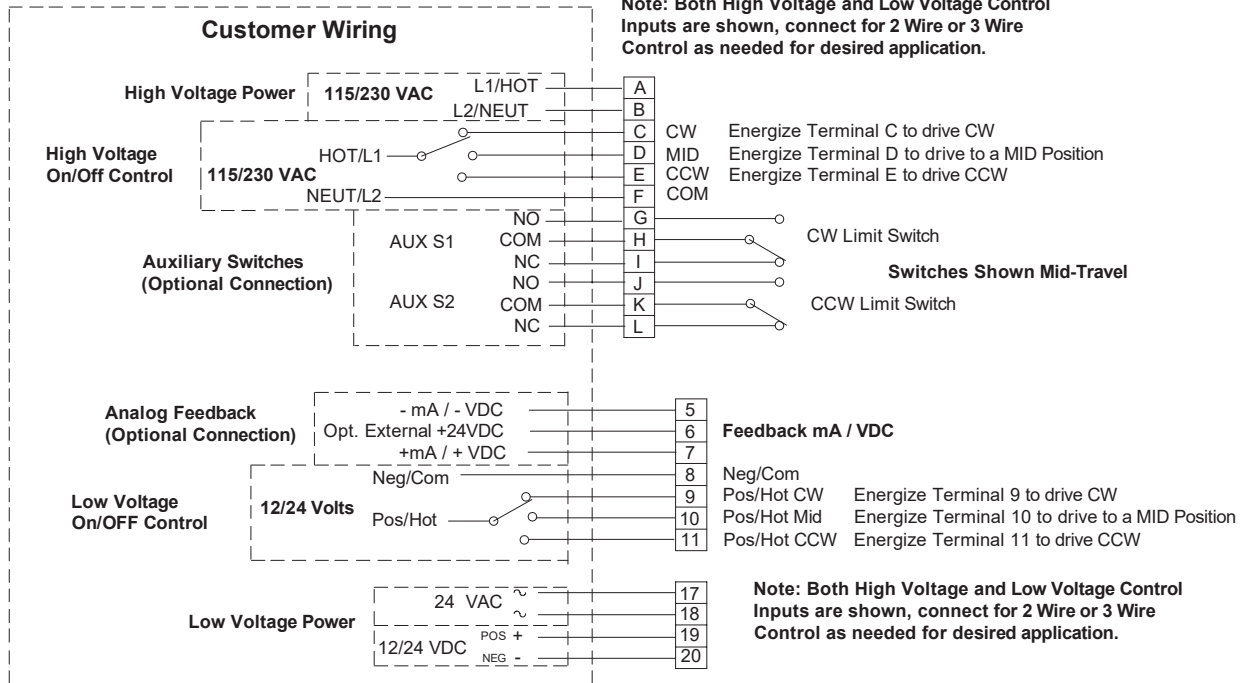

Note: Both High Voltage and Low Voltage Input Power connections shown, **CONNECT ONLY ONE** input voltage

Analog (mA / VDC / Resistive) Position Control Wiring

Note: Both High Voltage and Low Voltage Input Power connections shown, **CONNECT ONLY ONE** input voltage

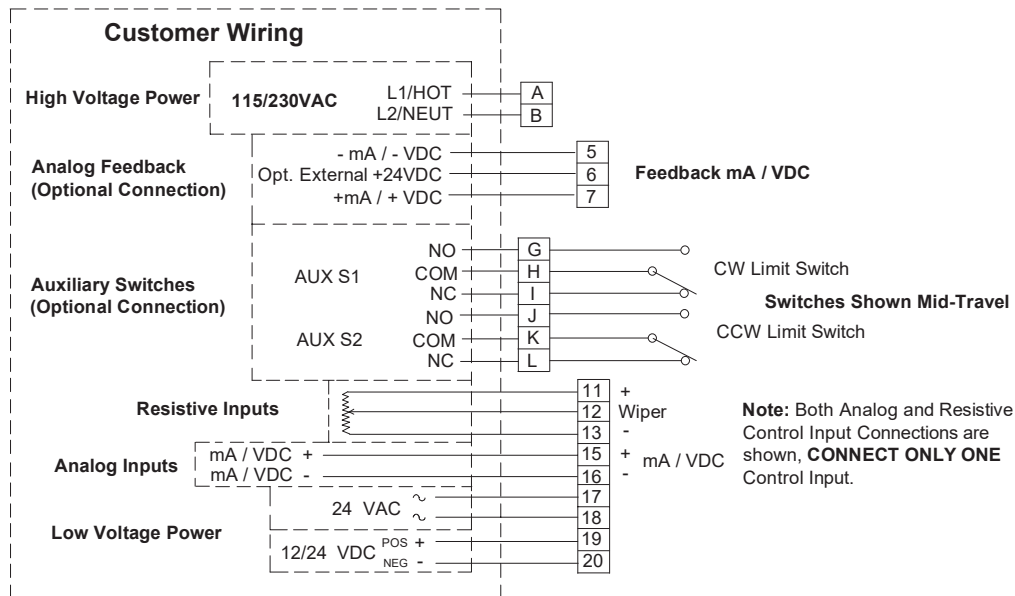

Note: Both High Voltage and Low Voltage Input Power connections shown, **CONNECT ONLY ONE** input voltage

WARNING: As the use of the actuator is application specific, a number of factors should be taken into account when selecting an actuator for a given application. Therefore, some of the applications in which the actuators are used are outside the scope of this document. If you have questions concerning the use, application or compatibility of the actuator with the intended service, contact Valmet for more information.

How to order – ADC-series electric actuators (150-600 lb-in)

Example:

Sample model code: ADCWX150UL2-UP

1	Series ⁽¹⁾
ADC	ADC
2	Enclosure
W	Weathertight (NEMA 4/4X)
WX	Weathertight & Explosion proof (NEMA 4/4X/7&9)
3	Torque
150	150 lb-in (12 lb-ft; 17 Nm)
300	300 lb-in (25 lb-ft; 34 Nm)
600	600 lb-in (50 lb-ft; 68 Nm)
4	Board options ⁽²⁾
UL2	Universal Board with SLA Battery Back-UP
UL4	Universal Board 180-Degrees with SLA Battery Back-UP
UL6	Universal Board 270-Degrees with SLA Battery Back-UP

1	2	3	4	5	6
ADC	WX	150	UL2	-	-UP
5	Other options				
-	No entry if standard				
I1 ⁽³⁾	14mm Female Square Output				
I2 ⁽³⁾	17mm Female Square Output				
MB ⁽⁴⁾	Modbus Communication				
Y1 ⁽³⁾	15mm Female Keyed Output				
Y2 ⁽³⁾	20mm Female Keyed Output				
Z	Handwheel				
6	Operating voltage				
-UP	Universal Power				

When ordering a 600lb Valvcon Electric Actuator to accompany Kimray's Rotary to Linear Adapter (R2L), please use the following 'Q' codes prefixes to ensure the firmware is flashed appropriately:

Q30243 ADCWX600UL2I1-UP Q30228 ADCWX600UL2I1Z-UP
Q30244 ADCWX600UL2I1MB-UP Q30229 ADCWX600UL2I1MBZ-UP

How to order – ADC-series electric actuators (1000-3000 lb-in)

Example:

Sample model code: LADCWX2000UL5Z-UP

1	Series ⁽¹⁾
LADC	LADC
2	Enclosure
W	Weathertight (NEMA 4/4X)
WX	Weathertight & Explosion proof (NEMA 4/4X/7&9)
3	Torque
1000	1000 lb-in (83 lb-ft; 113 Nm)
1500	1500 lb-in (125 lb-ft; 169 Nm)
2000	2000 lb-in (167 lb-ft; 226 Nm)
2500	2500 lb-in (208 lb-ft; 282 Nm)
3000	3000 lb-in (250 lb-ft; 339 Nm)
4	Board options ⁽²⁾
UL3	Universal Board with SLA Battery Back-UP
UL5	Universal Board 180-Degrees with SLA Battery Back-UP
UL7	Universal Board 270-Degrees with SLA Battery Back-UP

1	2	3	4	5	6
LADC	WX	2000	UL5	Z	-UP
5	Other options				
-	No entry if standard				
I2 ⁽³⁾	17mm Female Square Output				
I3 ⁽³⁾	19mm Female Square Output				
I4 ⁽³⁾	22mm Female Square Output				
MB ⁽⁴⁾	Modbus Communication				
Y2 ⁽³⁾	20mm Female Keyed Output				
Y3 ⁽³⁾	25mm Female Keyed Output				
Z	Handwheel				
6	Operating voltage				
-UP	Universal Power				

Notes:

- All ADC-Series actuators accept any of the following input voltages (12VDC, 24VDC, 24VAC, 115VAC and 230VAC), are rated for continuous duty cycle, include a holding brake, two auxiliary limit switches, 4-20mA or 0-10VDC, position feedback, wrench-operated manual override, CSA "C US" certification, and a heater/thermostat that can be user-enabled on the option board.
- Must select only one board option; all board options can be configured for On/Off or Modulating operation.
- The standard drive output for 150 - 600 lb-in actuators is a 3/4" female square; the standard drive output for 1000 - 3000 lb-in actuators is a 1" female square.
- The Modbus Communication option allows for controlling, and polling the unit for diagnostic information using a Modbus communication signal (RS-485; Two-Wire).

Valmet Flow Control Oy

Vanha Porvoontie 229, 01380 Vantaa, Finland.

Tel. +358 10 417 5000.

www.valmet.com/flowcontrol

Kimray Inc

52 NW 42nd St, Oklahoma City, OK 73118

Tel. +1 405 525 6601

kimray.com



Subject to change without prior notice.

Neles, Neles Easyflow, Jamesbury, Stonel, Valvcon and Flowrox, and certain other trademarks, are either registered trademarks or trademarks of Valmet Oyj or its subsidiaries in the United States and/or in other countries.

For more information www.neles.com/trademarks

