

HIGH PRESSURE CONTROL VALVES

CV



KIMRAY
INC.®

‡ Configuration of High Pressure Control Valve is a trademark of Kimray, Inc.

NOTE: We reserve the right to modify or change, without prior notice, any statement or information contained herein.
© Copyright 2020, Kimray, Inc.

STEM GUIDED HIGH PRESSURE CONTROL BOTTOM WORKS:	01:10.1 - 01:10.2
APPLICATIONS: For discharge of liquid or gas from vessels, separators, treaters, knockouts, and similar liquid accumulators. For Back Pressure or Pressure Reducing applications with pressure pilots.	
OPERATING PRESSURE RANGES: 0 psig to 6000 psig	
STEM GUIDED HIGH PRESSURE CONTROL VALVE BODIES & TRIM:	01:10.3
SOFT SEAT:	01:10.4
CAGE GUIDED HIGH PRESSURE CONTROL VALVE BOTTOM WORKS:	01:20.1 - 01:20.2
APPLICATIONS: For discharge of liquid or gas from vessels, separators, treaters, knockouts, and similar liquid accumulators. For Back Pressure or Pressure Reducing applications with pressure pilots.	
OPERATING PRESSURE RANGES: 0 psig to 4000 psig	
CAGE GUIDED HIGH PRESSURE CONTROL VALVE BODIES & TRIM:	01:20.3
NON-FREEZE DUMP VALVE BOTTOM WORKS:	01:30.1 - 01:30.2
APPLICATIONS: For discharge of liquid from vessels where freezing may occur due to high pressure drop	
OPERATING PRESSURE RANGES: 0 psig to 4000 psig	
SPLITTER & 3-WAY HIGH PRESSURE CONTROL VALVE:	01:40.1 - 01:40.3
APPLICATIONS: For splitting flow into two directions	
OPERATING PRESSURE RANGES: 0 psig to 3000 psig	
HIGH PRESSURE CONTROL VALVE STANDARD ACTUATOR:	01:50.1 - 01:50.4
APPLICATIONS: For discharge of liquid or gas from vessels, separators, treaters, knockouts, and similar liquid accumulators. For Back Pressure or Pressure Reducing applications with pressure pilots.	
DIAPHRAGM PRESSURE RANGES: 0 psig to 30 psig	
65 ACTUATOR:	01:60.1 - 01:60.2
APPLICATIONS: Allows a wider spring adjustment range for discharge of liquid or gas from vessels, separators, treaters, knockouts, and similar liquid accumulators. Allows a finer control when used with Back Pressure and Pressure Reducing Controllers. Used as an operator on 1" HPCV, 2" HPCV or 1" SMS.	
OPERATING PRESSURE RANGES: 0 psig to 45 psig	
METERING VALVE:	01:70.1 - 01:70.2
APPLICATIONS: This valve can be used to meter or control flow of liquids and/or gases on meter runs, flow lines or may be used as a choke under low pressure drop conditions where freezing is not a problem.	
Used anytime a reference control point is required in 64 th of an inch opening.	
OPERATING PRESSURE RANGES: 0 psig to 4000 psig	
R2L ACTUATOR / ADAPTOR:	01:80.1 - 01:80.2
APPLICATIONS: Utilizes (any) quarter-turn actuator with ISO-5211 connection in conjunction with Kimray HPCV to control level, flow, pressure, temperature of process fluid.	
MANUAL VALVE POSITIONER:	01:90.1 - 01:90.2
APPLICATIONS: For closing valves manually when supply is not available.	
TRITEX II ACTUATOR:	01:100.1
APPLICATIONS: For Kimray Control Valves with the Kimray TRITEX II: Flow control valve, Pressure control upstream/downstream/differential, Choke valve, Compressor controls, Gas lift valve or Dump valve.	
STEM GUIDED INNER VALVE TRIM CHARACTERISTICS:	01:200.1
STEM GUIDED INNER VALVE TRIM:	01:200.2
STEM GUIDED INNER VALVE TRIM ABRASION RESISTANCE:	01:200.3
CAGE GUIDED INNER VALVE TRIM CHARACTERISTICS:	01:210.1
CAGE GUIDED INNER VALVE TRIM:	01:210.2
COMPLETE VALVE CODES:	01:300.1 - 01:300.4
FLOW COEFFICIENT	01:I
LIQUID CAPACITY CHART	01:II
GAS CAPACITY CHART	01:III
DIMENSIONS 1" CVS SERIES	01:IV
DIMENSIONS 2" CVS & CVC SERIES	01:V
DIMENSIONS FLANGED BODIES CVS & CVC SERIES	01:VI
SEALS	01:VII
MATERIAL SPECIFICATIONS	01:VIII
ACTUATOR CRACK TO FULL OPEN	01:IX - 01:XI

HIGH PRESSURE CONTROL VALVES



CODE BUILDER MODEL CVS (STEM GUIDED)

Series:

CV = Control Valves

Model:

S = Stem Guided

Line Size:

1 = 1 NPS
2 = 2 NPS

End Connection:

Body Type:

A = Angle
T = Thru
D = Dual

Shell Material:

W = WCB Steel
X = Steel (WCB) w/Coating

Inner Valve Size:

Actuator:

0 = No Actuator	7 = - 65 Fail Close
1 = 3 - 15 psi Spring Fail Close	8 = Metering Valve (EP trim only)
2 = 6 - 30 psi Spring Fail Close	J = 2 - 10 psi Spring Fail Close (1" only)
3 = 9 - 45 psi Spring Fail Close	K = 4 - 20 psi Spring Fail Close
4 = 3 - 15 psi Spring Fail Open	L = 2 - 10 psi Spring Fail Open (1" only)
5 = 6 - 30 psi Spring Fail Open	M = 4 - 20 psi Spring Fail Open
6 = 9 - 45 psi Spring Fail Open	

S2 = 2000 psi FNPT
S4 = 4000 psi FNPT
S6 = 6000 psi FNPT
AR = 150 RF
BR = 300 RF
DR = 600 RF
FR = 900/1500 RF
GR = 2500 RF
DJ = 600 RTJ
FJ = 900/1500 RTJ
GJ = 2500 RTJ
P5 = API 5000

	1" Line Size			2" Line Size		
	Linear	Quick Open	E.P.	Linear	Quick Open	E.P.
1/8"	02L	02Q	02E			
3/16"	03L	03Q				
1/4"	04L	04Q	04E	04L	04Q	04E
3/8"	06L	06Q		06L	06Q	
7/16"						07E
1/2"	08L	08Q	08E	08L	08Q	
5/8"						10E
3/4"				12L	12Q	
7/8"						14E
1"		16Q		16L	16Q	
1 1/2"					24Q	

Service Type:	Trim Materials (Stem - Plug - Seat)		
	Linear	Quick Open	E.P.
S = Standard	S3-CR-D2	S3-CB-CB	S3-CR-D2
C = Corrosive	S6-S6-S6	N/A	S6-S6-S6
E = Erosive	S3-CB-ZR	S3-CB-ZR	S3-CB-ZR
M = Mixed Duty	S7-S7-S7	N/A	S7-S7-S7

CV S 2 S2 T W 16L 2 S

Options: Additional cost and lead times will apply
If multiple options required input in sequential order
Leave blank if no options required

1 = NACE Certification (Corrosive Option Only)
2 = Hydrostatic Test Certification
3 = MTR (Shell Components)
A = AFLAS Elastomers (Green)
E = VEE Packing
G = Graphite Vee Packing
H = HSN Elastomers
V = FKM Elastomers (Yellow)
X = Export (Hydrostatic test, MTR & 3.1)

Not all selections available on all products listed.
See product pages 01:10.1 - 01:10.4 for available options

Series: **CV = Control Valves**

Model: **C = Cage Guided**

Line Size:
2 = 2 NPS
 3 = 3 NPS
 4 = 4 NPS
 6 = 6 NPS
 8 = 8 NPS
 0 = 10 NPS

End Connection: **3", 4", 6", 8" & 10"**

Body Type: **T = Thru**

Shell Material:
W = WCB Steel
 X = Steel (WCB) w/Coating

Trim Type: _____

Actuator:
FEP = Equal Percentage
 FQK = Quick Open
 REP = Reduced E.P.

Service Type:	Plug	Cage	Seat
S = Standard	D2	S6	D2
C = Corrosive	S6	S6	S6
E = Erosive	ZR	S6	D2

Options:
 0 = No Actuator
 1 = 3 - 15 psi Spring Fail Close
2 = 6 - 30 psi Spring Fail Close
 3 = 9 - 45 psi Spring Fail Close
 4 = 3 - 15 psi Spring Fail Open
 5 = 6 - 30 psi Spring Fail Open
 6 = 9 - 45 psi Spring Fail Open
 8 = Metering Valve (2"-4" only)

Pressure Ratings:
S1 = 1500 psi FNPT
 S4 = 4000 psi FNPT
 S6 = 6000 psi FNPT
 AR = 150 RF
 BR = 300 RF
 DR = 600 RF
 FR = 900/1500 RF
 GR = 2500 RF
 DJ = 600 RTJ
 FJ = 900/1500 RTJ
 AR = 150 RF
 BR = 300 RF
 DR = 600 RF
 DJ = 600 RTJ

Final Code: **CV C 2 S2 T W FEP 2 S**

Not all selections available on all products listed.
See product pages 01:20.1 - 01:20.3 for available options

Options: Additional cost and lead times will apply
If multiple options required input in sequential order
Leave blank if no options required

- 1 = NACE Certification (Corrosive Option Only)
- 2 = Hydrostatic Test Certification
- 3 = MTR (Shell Components)
- A = AFLAS Elastomers
- E = VEE Packing
- G = Graphite Vee Packing
- H = HSN Elastomers
- V = FKM Elastomers
- X = Export (Hydrostatic test, MTR & 3.1)

* Other materials available upon request

HIGH PRESSURE CONTROL VALVES



CODE BUILDER
MODEL CVN (NON FREEZE)

Series:

CV = Control Valves

Model:

N = Non Freeze

Line Size:

1 = 1 NPS

End Connection:

S4 = 4000 psi NPT

Body Type:

A = Angle

Shell Material:

D = Ductile Iron
E = Ductile Iron w/Coating

Inner Valve Size:

	Linear	Quick Open
1/4"	04L	04Q
3/8"	06L	06Q
1/2"	08L	08Q

Actuator:

2 = 6 - 30 psi Spring Fail Close
7 = - 65 Fail Close

Service Type:

S = Standard
C = Corrosive

Trim Materials
(Stem - Plug - Seat)

	Linear	Snap
S	S3-CR-D2	S3-CB-CB
C	S6-S6-S6	N/A

CV N 1 S4 A D 04L 2 S

Options: Additional cost and lead times will apply
If multiple options required input in sequential order
Leave blank if no options required

- 1 = NACE Certification (Corrosive Option Only)
- 2 = Hydrostatic Test Certification
- 3 = MTR (Shell Components)
- A = AFLAS Elastomers
- V = FKM Elastomers
- X = Export (Hydrostatic test, MTR & 3.1)

Not all selections available on all products listed.
See product pages 01:30.1 - 01:30.2 for available options

Series:

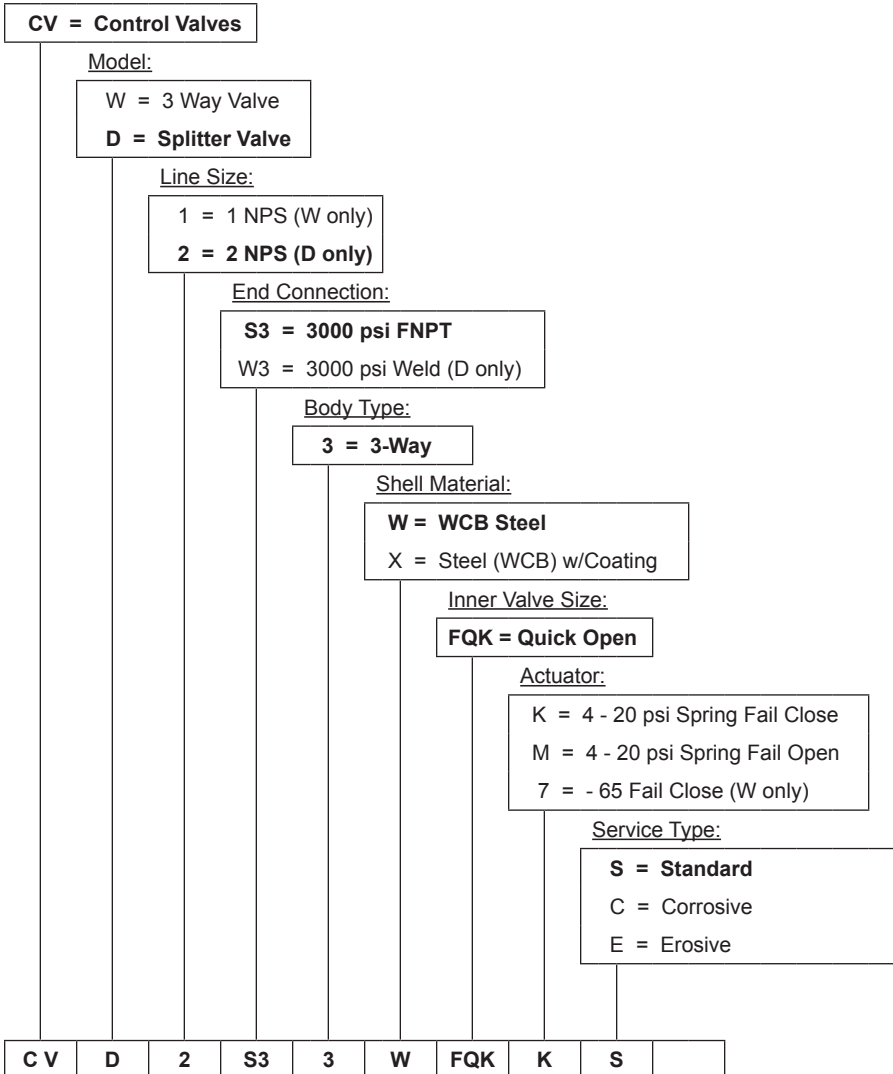

Options: Additional cost and lead times will apply
If multiple options required input in sequential order
Leave blank if no options required

- 1 = NACE Certification (Corrosive Option Only)
- 2 = Hydrostatic Test Certification
- 3 = MTR (Shell Components)
- A = AFLAS Elastomers
- V = FKM Elastomers
- X = Export (Hydrostatic test, MTR & 3.1)

Not all selections available on all products listed.
See product pages 01:40.1 - 01:40.2 for available options

NOTES:



Kimray is an ISO 9001- certified manufacturer.

APPLICATIONS:

For discharge of liquid or gas from vessels, separators, treaters, knockouts and other similar liquid accumulators.

For back pressure or pressure reducing applications with pressure pilots.

FEATURES:

- Compact design
- O-Ring sealed seat
- Valve travel indicator
- Field-reversible topworks
- Teflon-packed stuffing box

CERTIFICATIONS:

Canadian Registration Number (CRN):
0C15021.24567890NTY





Kimray is an ISO 9001- certified manufacturer.

INNER VALVE SPECIFICATIONS:

The 1" HPCV standard valve plugs consist of a carbide ball rigidly connected to a 303 stainless steel stem. Standard seats are made of heat-treated tool steel.

The 2" HPCV standard valve plugs for 1/2" and smaller consist of a carbide ball rigidly connected to a 303 stainless steel stem. Standard valve plugs for 3/4" and 1" consist of a hardened high chrome alloy ball rigidly connected to a 303 stainless steel stem. Standard seats are made of heat-treated tool steel.

Inner valves can be made from a wide selection of materials. Specify when ordering.

-  Control Valve Diaphragm Assembly
-  Control Valve Diaphragm Pressure
-  Upstream Pressure
-  Downstream Pressure

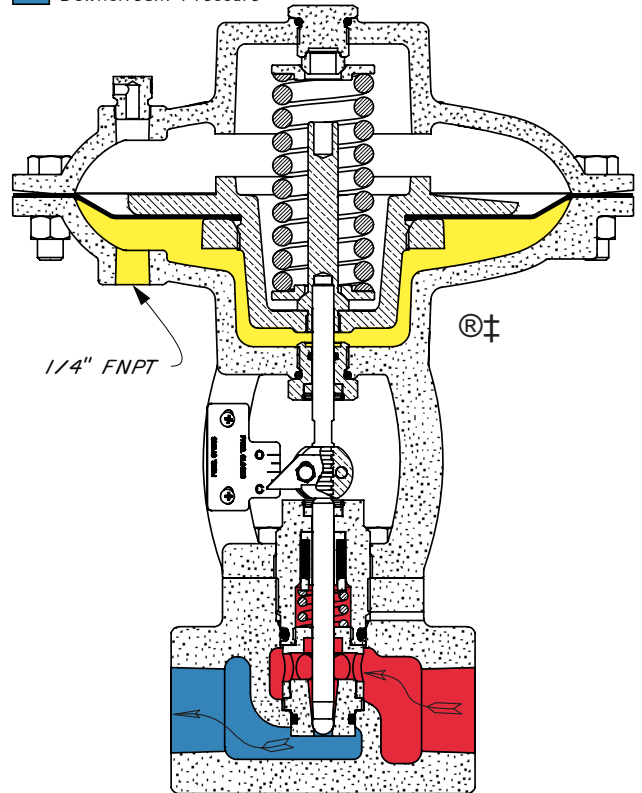

Order Code †	Line Size	Stem Travel	Inner Valve	Linear		Quick Open		Equal Percent	
				Cv	Cf	Cv	Cf	Cv	Cf
See page 01:300.1	1"	1/2"	1/8"	1.10	0.58	0.40	0.73	0.34	0.73
			3/16"	1.50	0.59	0.92	0.74	----	----
			1/4"	2.17	0.78	1.74	0.68	1.99	0.66
			3/8"	3.20	0.91	3.86	0.74	----	----
			1/2"	5.70	0.94	5.93	0.90	6.49	0.78
	2"	3/4"	1/4"	3.00	0.55	1.87	0.65	1.72	0.65
			3/8"	4.00	0.77	3.84	0.76	----	----
			7/16"	----	----	----	----	5.40	0.60
			1/2"	7.20	0.78	6.63	0.80	----	----
			5/8"	----	----	----	----	10.8	0.58
			3/4"	12.0	0.80	10.9	0.78	----	----
	1" Soft Seat	1 1/2"	1"	21.0	0.77	15.8	0.70	----	----
			2"	29.8	0.75	----	----	----	----

NOTES:

For standard & optional seals, metals, Cf Cv values, material specifications & dimensions see technical data on pages 01:1 - 01:X1

† For complete valve codes see page 01:300.1, For code builder see page 01:00.2
Max W.P. values based on -20°F to 100°F.

HIGH PRESSURE CONTROL VALVES



STEM GUIDED BOTTOM WORKS MODEL CVS PARTS DRAWING

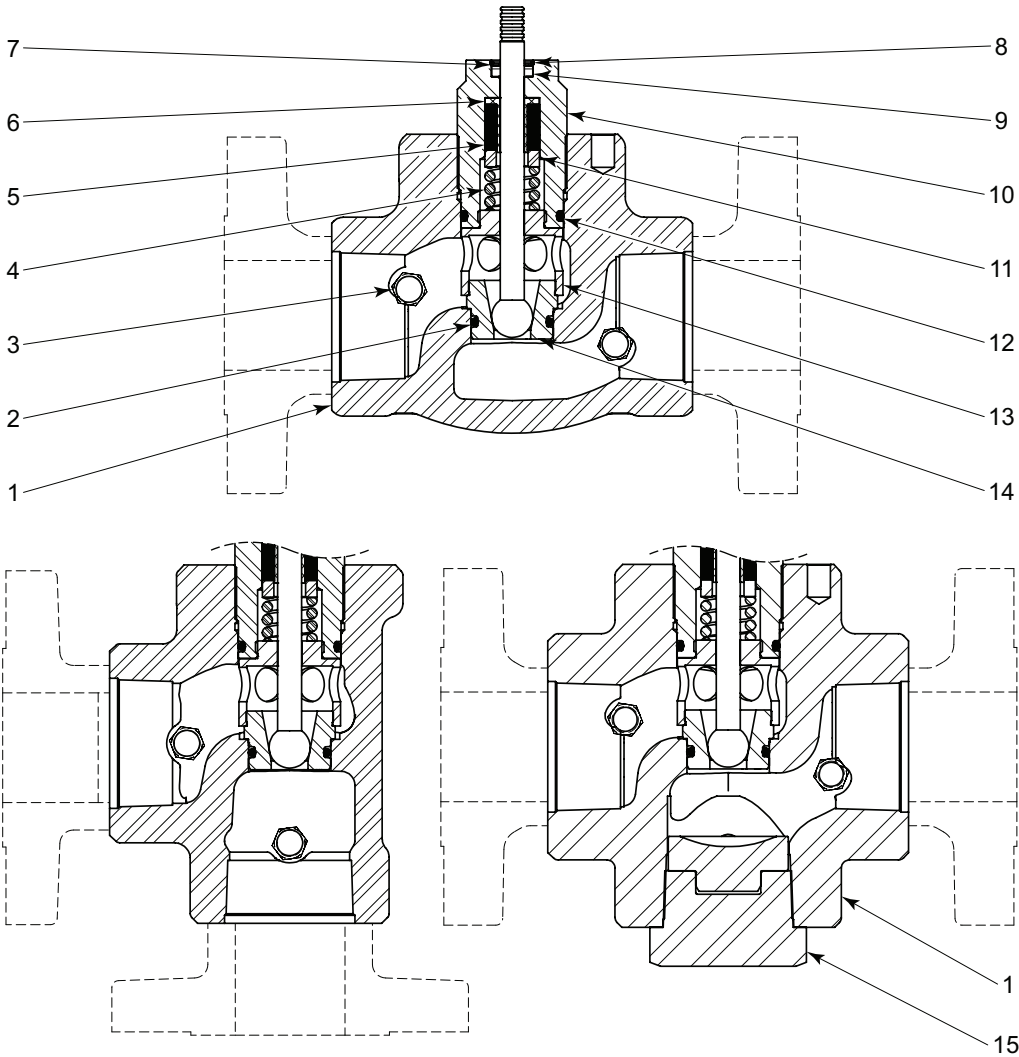

ITEM	QTY.	DESCRIPTION	PART NO.							
			STANDARD		CORROSIVE		EROSIVE		MIXED DUTY	
			1 INCH	2 INCH	1 INCH	2 INCH	1 INCH	2 INCH	1 INCH	2 INCH
1	1	Body	See Table On Page 01:10.3							
2	1	O-Ring *	155	157	155	157	155	157	155	157
3	2	Plug	----	699	----	699SS6	----	699	----	699SS6
4	1	Spring	465	509	465HAC	509HAC	465	509	465HAC	509HAC
5	(QTY)	Packing Ring *	484 (4)	533 (6)	484 (4)	533 (6)	484 (4)	533 (6)	484 (4)	533 (6)
6	1	Packing Sleeve *	485	534	485	534	485	534	485	534
5&6	1	Optional VEE Packing 450°F max	5117	5118	5117	5118	5117	5118	5117	5118
		Optional Grafoil Packing 450°F max	----	5118GF	----	5118GF	----	5118GF	----	5118GF
7	1	Retainer	486	528	486	528	486	528	486	528
8	1	Snap Ring *	938	940	938	940	938	940	938	940
9	1	Felt Wiper *	480	527	480	527	480	527	480	527
10	1	Stuffing Box	479	526	479SS6	526SS6	479	526	479SS6	526SS6
11	1	Packing Follower	482SS6	531SS6	482SS6	531SS6	482SS6	531SS6	482SS6	531SS6
12	1	O-Ring *	156	520	156	520	156	520	156	520
13	1	Cage	2837	2889	2837SS6	2889SS6	2837	2889	2837	2889PH
14	1	Trim Set	See Table On Page 01:10.3							
15	1	2" NPT Hex Plug w/Wear Plug	----	7886ASB	----	7886ASB	----	7886ASB	----	7886ASB
2" NPT Hex Plug for Angle T-Body (not shown)			----	7665R	----	7665R	----	7665R	----	7665R
Repair Kits			RFA	RFE	RFA	RFE	RFA	RFE	RFA	RFE
Stuffing Box Assemblies		Order Code	EAW	EBY	EAWSS6	EBYSS6	EAW	EBY	EAWSS6	EBYSS6
		Max W.P. psig	6000	6170	6000	6170	6000	6170	6000	6170

* These parts are recommended spare parts and are stocked as repair kits.

All Pictures shown are for illustration purpose only. Actual product may vary due to product enhancement.

THRU BODIES AVAILABLE							
ITEM	QTY.	DESCRIPTION	PART NO.				
			1 INCH		2 INCH		
			THRU	ANGLE	THRU	ANGLE	DUAL PORT (T-BODY)
1	1	2000 psig NPT	----	----	493	496	----
		4000 psig NPT	452	453	494	497	7622
		6000 psig NPT	5029	7509	4083	4355	7702
		150RF	2374RF	2772RF	4510	2791	7765
		300RF	5335RF	2773RF	4512	2793	7766
		600RF	1945RF	2133RF	4513	2795	7767
		1500RF	2768RF	----	4516	2442	7768
		600RTJ	2054RTJ	2778RTJ	4514	2816	----
		1500RTJ	2771RTJ	2780RTJ	4515	1742	7769
		2500RTJ	----	----	4230	----	----
		API 5000	----	----	6604	6612	7764
Coated Bodies available with "E" shell material							

TRIM SETS AVAILABLE (Other materials available see page 01:200.2)									
ITEM	QTY.	SIZE	SERVICE	1" LINE SIZE			2" LINE SIZE		
				Linear	Quick Open	E.P.	Linear	Quick Open	E.P.
14	1	1/8"	Standard	T2842	T2856	T6400			
			Corrosive	T2842SS6		T6400SS6			
			Erosive						
			Mixed Duty	T2842PH					
		3/16"	Standard	T2841	T2855				
			Corrosive	T2841SS6					
			Erosive						
			Mixed Duty	T2841PH					
		1/4"	Standard	T2840	T2854	T4730	T2895	T2890	T6404
			Corrosive	T2840SS6		T4730SS6			T6404SS6
			Erosive			T4730ZR			
			Mixed Duty	T2840PH			T2895PH		T6404PH
		3/8"	Standard	T2838	T2853		T2896	T2891	
			Corrosive	T2838SS6			T2896SS6		
			Erosive					T2891ZR	
			Mixed Duty	T2838PH			T2896PH		
		7/16"	Standard						T2993
			Corrosive						T2993SS6
			Erosive						T2993ZR
			Mixed Duty						T2993PH
		1/2"	Standard	T2839	T5307	T4732	T2897	T2892	
			Corrosive	T2839SS6		T4732SS6	T2897SS6		
			Erosive			T4732ZR			
			Mixed Duty	T2839PH			T2897PH		
		5/8"	Standard						T2992
			Corrosive						T2992SS6
			Erosive						T2992ZR
			Mixed Duty						T2992PH
		3/4"	Standard				T2898	T4690	
			Corrosive				T2898SS6		
			Erosive					T4690ZR	
			Mixed Duty				T2898PH		
		7/8"	Standard						T2947
			Corrosive						T2947SS6
			Erosive						T2947ZR
			Mixed Duty						T2947PH
		1"	Standard				T2899	T4691	
			Corrosive				T2899SS6		
			Erosive				T2899ZR		
			Mixed Duty				T2899PH		

NOTES:



**1" & 2" HPCV OVERSIZED SOFT SEATS STUFFING BOX ASSEMBLY
PARTS DRAWING**

For increased flow at low operating pressure. Maximum pressure drop is 300 psig For on - off service only.
Uses standard valve body
Teflon seal

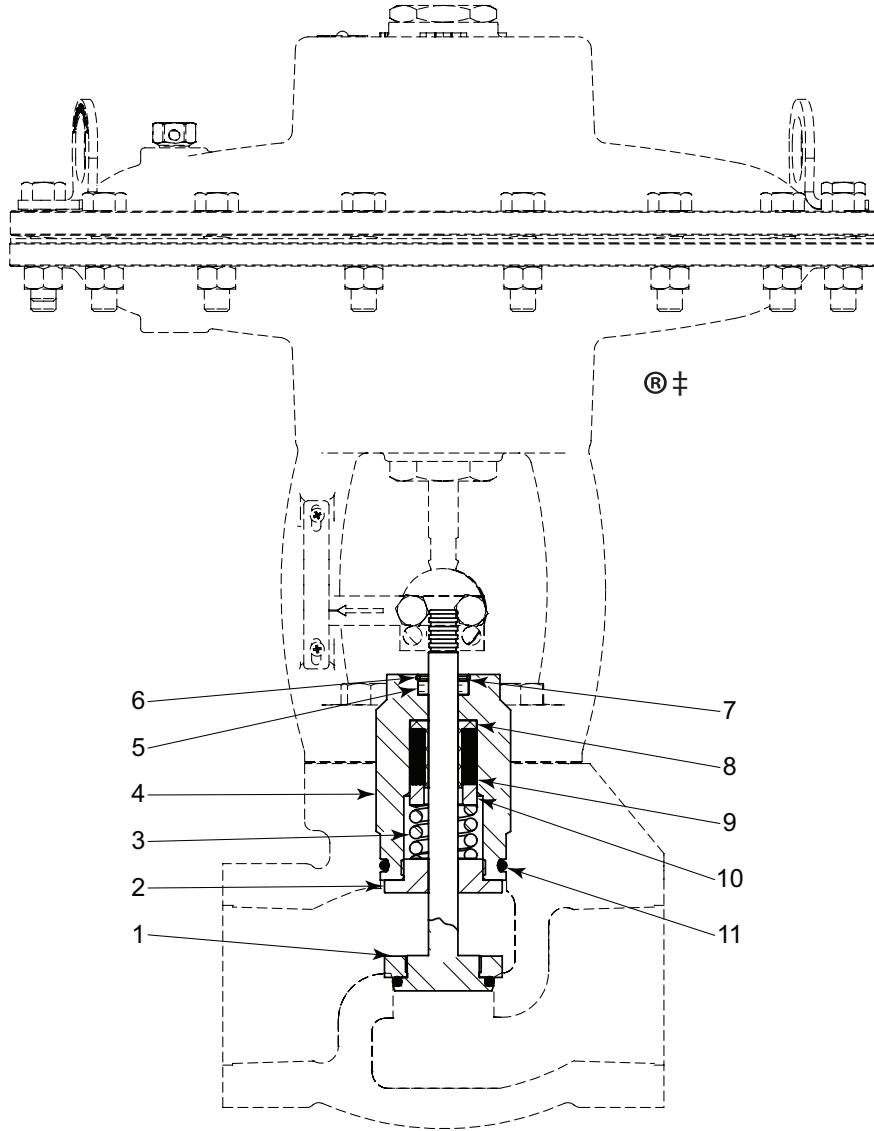

ITEM	QTY.	DESCRIPTION	PART NO.			
			STANDARD		CORROSIVE	
			1 INCH	2 INCH	1 INCH	2 INCH
1	1	Soft Seat	2137	2136	2137SS6	2136SS6
2	1	Nut	1828	1829	1828SS6	1829SS6
3	1	Spring	465	509	465HAC	509HAC
4	1	Stuffing Box	479	526	479SS6	526SS6
5	1	Felt Wiper *	480	527	480	527
6	1	Snap Ring *	938	940	938	940
7	1	Retainer	486	528	486	528
8	1	Packing Sleeve *	485	534	485	534
9	(QTY)	Packing Ring *	484 (4)	533 (6)	484 (4)	533 (6)
10	1	Packing Follower	482SS6	531SS6	482SS6	531SS6
11	1	O-Ring *	156	520	156	520
Repair Kits			RFA	RFE	RFA	RFE
Stuffing Box Assemblies			EAX	EBZ	EAXSS6	EBZSS6

* These parts are recommended spare parts and are stocked as repair kits.

APPLICATIONS:

For discharge of liquid or gas from vessels, separators, treaters, knockouts and other similar liquid accumulators.





For back pressure or pressure reducing applications with pressure pilots.

FEATURES:

- Compact design
- Soft seat with metal-to-metal backup
- Valve travel indicator
- Field-reversible topworks
- Teflon-packed stuffing box
- Bubble-tight shut-off
- Piston balanced seat assembly

CERTIFICATIONS:

Canadian Registration Number (CRN):
0C15019.24567890NTY
Kimray is an ISO 9001- certified manufacturer.

-  Control Valve Piston Assembly
-  Control Valve Diaphragm Assembly
-  Control Valve Diaphragm Pressure
-  Upstream Pressure
-  Downstream Pressure

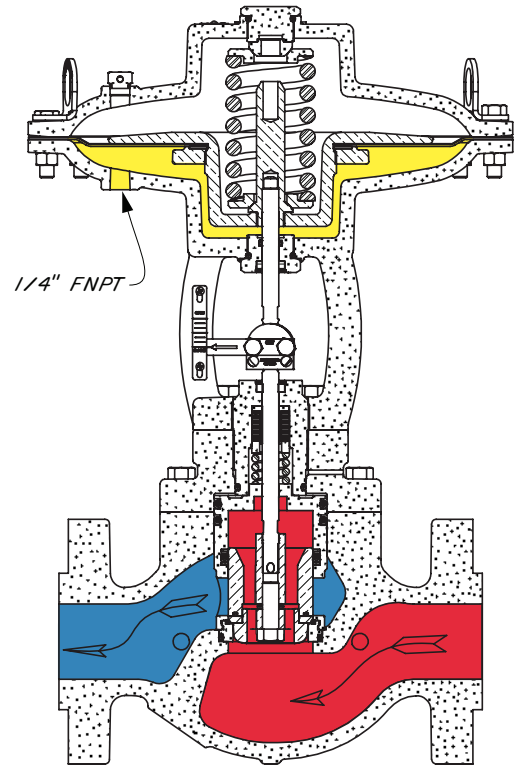

Order Code **	Line Size	Flow Characteristic	Inner Valve	Stem Travel	Max. W.P. psig ***	Cv	Cf	
See page 01:300.2	2"	EP	1 1/2"	3/4"	4000	28.6	0.75	
			2"			57.0	0.76	
			1 1/2"	3/4"		6000	28.6	0.75
			2"				57.0	0.76
	3"		2"	1 3/8"	1480		52.6	0.75
			3"				107	0.76
	4"		3"	1 3/4"		115	0.75	
			4 3/8"			222	0.75	
	6"	4 3/8"	2 1/2"	222	0.75			
		6 3/4"		431	0.75			
	8"	Reduced EP		6"	453	0.75		
		Equal Percentage		8 1/2"	630	0.75		
Modified EP		8 1/2"	810	0.75				
10"	Reduced EP	6"	655	0.75				
	Equal Percentage	8 1/2"	884	0.75				
	Modified EP	8 1/2"	1091	0.75				

NOTES:

For standard & optional seals, metals, Cf Cv values, material specifications & dimensions see technical data on pages 01:1 - 01:XI

** For complete valve codes see pages 01:300.2

*** Max W.P. values based on -20°F to 100°F.

HIGH PRESSURE CONTROL VALVES

PISTON BALANCED / CAGE GUIDED BOTTOM WORKS
MODEL CVC PARTS DRAWING

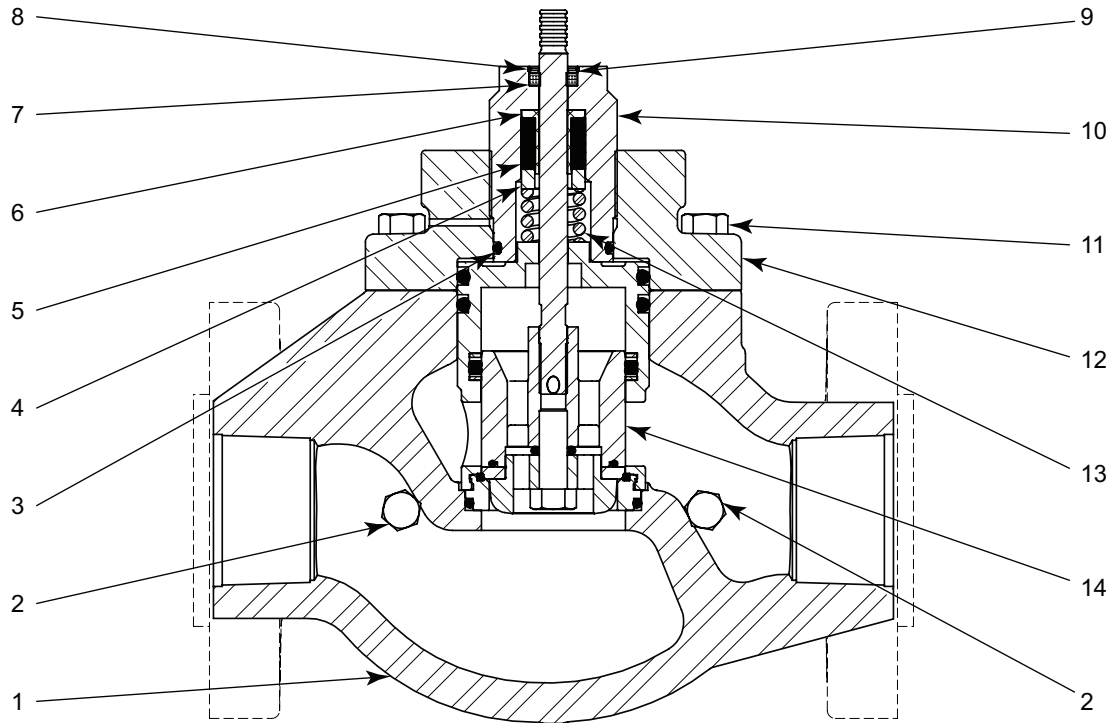

ITEM	QTY.	DESCRIPTION	PART NO.					
			STANDARD					
			2 INCH	3 INCH	4 INCH	6 INCH	8 INCH	10 INCH
1	1	Body	Coated Bodies available with "E" shell material					
		1500 psig NPT Thru	4813	----	----	----	----	----
		4000 psig NPT Thru	4764	----	----	----	----	----
		150RF Thru	5071	6427	6428	6429	7040RF	7173
		300RF Thru	5051	5070	5249	5302	6661RF	6888RF
		600RF Thru	4712	4950	5146	5322	6567RF	6572RF
		600RTJ Thru	4713	4951	----	----	6567RTJ	----
		1500RF Thru	4714	----	----	----	----	----
		1500RTJ Thru	4715	----	----	----	----	----
		3 INCH 600RF Thru	4871	----	----	----	----	----
3 INCH 600RTJ Thru	4872	----	----	----	----	----		
2	2	Plug	699			292SS6		
3	1	O-Ring *	520	2081				
4	1	Packing Follower *	531SS6	4978SS6		5340SS6		
5	(QTY)	Packing Ring *	533 (6)	4977 (8)		5339 (8)		
6	1	Packing Sleeve *	534	4979		5341		
5&6	1	Optional VEE Packing 450°F max	5118	----	----	----	----	----
		Optional Grafoil Packing 450°F max	5118GF	----	----	----	----	----
7	(QTY)	Wiper *	527 (1)	4969 (2)		5337 (2)		
8	1	Snap Ring *	940	4968		5311		
9	1	Retainer	528	4970		5338		
10	1	Stuffing Box	526	4976		5346SS6		
11	(QTY)	Bolt	524 (8)	4991 (8)	5134 (12)	5323 (12)		
12	1	Upper Housing	4724	4958	5133	5301	6637	
13	1	Spring	509	4980		5347		
14	1	Plug Assembly	See Table On Page 01:20.3					
Repair Kits			RUR	RUT	RUU	RWD	RWF	

* These parts are recommended spare parts and are stocked as repair kits.

All Pictures shown are for illustration purpose only. Actual product may vary due to product enhancement.

PISTON BALANCED / CAGE GUIDED PLUG ASSEMBLY MODEL CVC PLUG ASSEMBLY PARTS DRAWING

ITEM	QTY.	DESCRIPTION	PART NO.					
			2 INCH	3 INCH	4 INCH	6 INCH	8 & 10 INCH	
STANDARD								
1	1	Cage	6459SS6	6460SS6	5544SS6	5430SS6	6568SS6	
2	2	O-Ring *	4768	2745	5144	2353	6640	
3	2	Back Up *	4771T	4988T	5145T	5321T	6635T	
4	1	Quad Ring *	4769Q	4992Q	5142Q	5318Q	6634Q	
5	1	Piston Assembly	6466ASS6	6467ASS6	6721ASS6	6723ASS6	6569ASS6	
6	1	O-Ring *	4773	807		1151		
7	1	O-Ring *	4086	2099	6724	6725	6642	
8	1	Seat Disc	6641	6673	6720	6722	6643	
9	1	Seal Ring *	6468P	6469P	5584P	5387P	6571P	
10	1	O-Ring *	2099	4983	5143	5319	6636	
11	1	Seat	6464	6465	5583	5375SS6	6570S6	
12	1	Ratio Plug	Equal Percentage	4720	4985	5139	5313	6609
			Reduced E.P.	4927	5123	5255	6425	6647
			Modified E.P.	----	----	----	----	6648
			Quick Open	6672	7094	----	----	----
13	1	Bolt	4767SS6	4986SS6		5354SS6		
Equal Percentage Plug Assembly			EFB	EFC	EFF	EFQ	EIC	
Reduced E.P. Plug Assembly			EFR	EHZ	EVK	MGE	MGI	
Modified E.P. Assembly			----	----	----	----	MGJ	
Quick Open Plug Assembly			EFBQO	EFCQO	----	----	----	
CORROSIVE								
1	1	Cage	6459SS6	6460SS6	5544SS6	5430SS6	6568SS6	
2	2	O-Ring *	4768	2745	5144	2353	6640	
3	2	Back Up *	4771T	4988T	5145T	5321T	6635T	
4	1	Quad Ring *	4769Q	4992Q	5142Q	5318Q	6634Q	
5	1	Piston Assembly	6466ASS6	6467ASS6	6721ASS6	6723ASS6	6569ASS6	
6	1	O-Ring *	4773	807		1151		
7	1	O-Ring *	4086	2099	6724	6725	6642	
8	1	Seat Disc	6641SS6	6673SS6	6720SS6	6722SS6	6643SS6	
9	1	Seal Ring *	6468P	6469P	5584P	5387P	6571P	
10	1	O-Ring *	2099	4983	5143	5319	6636	
11	1	Seat	6464SS6	6465SS6	5583SS6	5375SS6	6570S6	
12	1	Ratio Plug	Equal Percentage	4720SS6	4985SS6	5139SS6	5313SS6	6609SS6
			Reduced E.P.	4927SS6	5123SS6	5255SS6	6425SS6	6647SS6
			Modified E.P.	----	----	----	----	6648SS6
			Quick Open	6672SS6	7094SS6	----	----	----
13	1	Bolt	4767SS6	4986SS6		5354SS6		
Equal Percentage Plug Assembly			EFBS6	EFC6	EFF6	EFQS6	EICS6	
Reduced E.P. Plug Assembly			EFRS6	EHZS6	EVKS6	MGES6	MGIS6	
Modified E.P. Assembly			----	----	----	----	MGJS6	
Quick Open Plug Assembly			EFBQOS6	EFCQOS6	----	----	----	
EROSIVE								
1	1	Cage	6459SS6	6460SS6	5544SS6	5430SS6	6568SS6	
2	2	O-Ring *	4768	2745	5144	2353	6640	
3	2	Back Up *	4771T	4988T	5145T	5321T	6635T	
4	1	Quad Ring *	4769Q	4992Q	5142Q	5318Q	6634Q	
5	1	Piston Assembly	6466A	6467ASS6	6721ASS6	6723ASS6	6569ASS6	
6	1	O-Ring *	4773	807		1151		
7	1	O-Ring *	4086	2099	6724	6725	6642	
8	1	Seat Disc	6641ZR	6673ZR	6720ZR	6722ZR	6643ZR	
9	1	Seal Ring *	6468P	6469P	5584P	5387P	6571P	
10	1	O-Ring *	2099	4983	5143	5319	6636	
11	1	Seat	6464	6465	5583	5375SS6	6570S6	
12	1	Ratio Plug	Equal Percentage	4720	4985	5139	5313	6648
			Reduced E.P.	4927	5123	5255	6425	6647
			Modified E.P.	----	----	----	----	6609
			Quick Open	6672	7094	----	----	----
13	1	Bolt	4767SS6	4986SS6		5354SS6		
Equal Percentage Plug Assembly			EFBZR	EFCZR	EFFZR	EFQZR	EICZR	
Reduced E.P. Plug Assembly			EFRZR	EHZZR	EVKZR	MGEZR	MGIZR	
Modified E.P. Assembly			----	----	----	----	MGJZR	
Quick Open Plug Assembly			EFBQOZR	EFCQOZR	----	----	----	

* These parts are recommended spare parts and are stocked as repair kits.

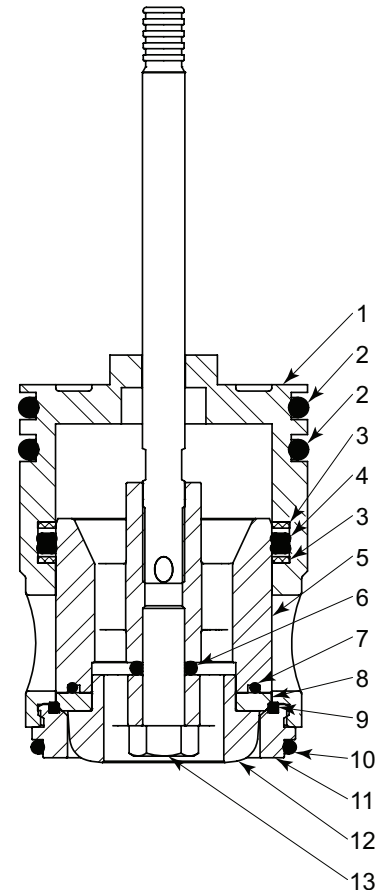

All Pictures shown are for illustration purpose only. Actual product may vary due to product enhancement.

NOTES:



Kimray is an ISO 9001- certified manufacturer.

APPLICATIONS:

For the discharge of liquid from vessels where freezing may occur due to high pressure drop. The inner valve is located to utilize vessel heat to help prevent freezing.

Recommended for use as a fail close valve only in non-freeze applications. Excessive diaphragm pressure would be required for fail open service.

The -65 allows a wider spring adjustment range for the discharge of liquid from vessels where freezing may occur due to high pressure drop.

FEATURES:

- Compact design
- Carboloy valve plug
- O-Ring-sealed seat
- Valve travel indicator
- Teflon-packed stuffing box
- Can be used as a standard 1" angle valve by reversing the direction of flow.
- Easy removal of seat
- 1" NPT inlet and outlet
- 2" NPT vessel mounting

STEM TRAVEL:

- SMS - 1/2" maximum
- 65 SMS - 3/4" maximum

INNER VALVE SPECIFICATIONS:

Standard valve plugs consist of a carbide ball rigidly connected to a 303 stain-less steel stem.

Standard seats are made of heat-treated tool steel.

Inner valves can be made from a wide selection of materials. Specify when ordering.

CERTIFICATIONS:

Kimray is an ISO 9001- certified manufacturer.

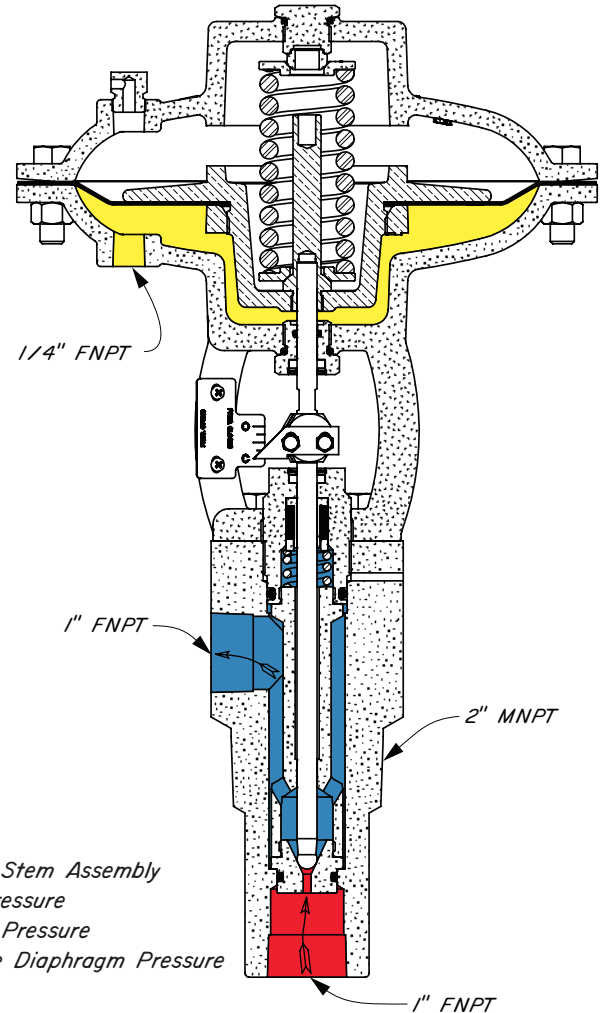

- Motor Valve Stem Assembly
- Upstream Pressure
- Downstream Pressure
- Control Valve Diaphragm Pressure



Order Code †	Body Size & Type	Flow Characteristic	Inner Valve	Max Stem Travel	Max Δ P	Max. W.P. psig ††	Cv	Cf
See page 01:300.4	1" NPT Angle	Quick Opening (Carbide)	1/4"	SMS - 1/2" -65 SMS - 3/4"	2000	4000	1.85	0.76
					4000		1.85	0.76
			3/8"		800		4.15	0.71
					4000		4.15	0.71
			1/2"		450		5.11	0.73
					4000		5.11	0.73
		Linear	1/4"		800		2.11	0.72
					4000		6.34	0.77
			3/8"		800		3.96	0.74
					4000		3.96	0.74
			1/2"		450		6.34	0.77
					4000		6.34	0.77

NOTES:

For standard & optional seals, metals, Cf Cv values, material specifications & dimensions see technical data on pages 01:1 - 01:XI

† For complete valve codes see pages 01:300.4

†† Max W.P. values based on -20°F to 100°F.

HIGH PRESSURE CONTROL VALVES



NON FREEZE DUMP VALVE BOTTOM WORKS
 MODEL CVN BOTTOM WORKS PARTS DRAWING

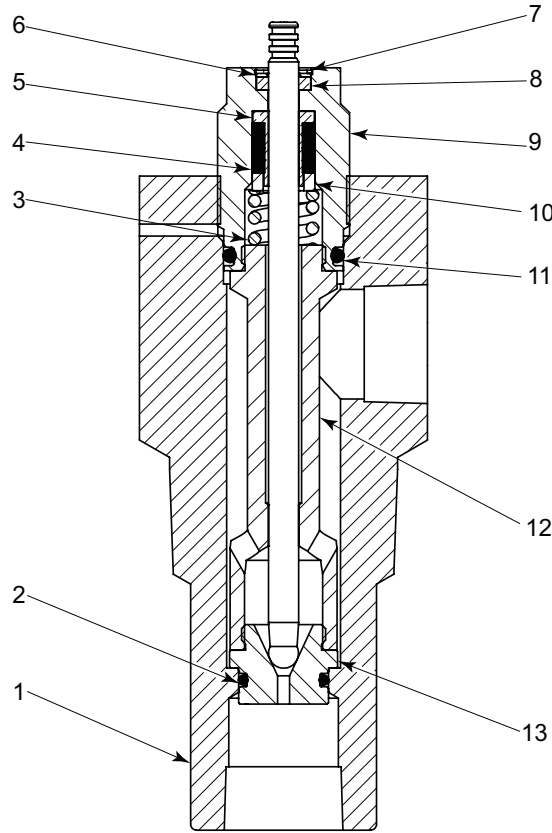

ITEM	QTY.	DESCRIPTION	PART NO.				
			STANDARD	CORROSIVE	EROSIVE		
1	1	Body	1200	1200SS6	1200		
2	1	O-Ring	155	155	155		
3	1	Spring *	465	465HAC	465		
4	(QTY)	Packing Ring	484 (4)	484 (4)	484 (4)		
5	1	Packing Sleeve *	485	485	485		
4&5	1	Optional VEE Packing 450°F max *	5117	5117	5117		
6	1	Retainer	486	486	486		
7	1	Snap Ring *	938	938	938		
8	1	Felt Wiper *	480	480	480		
9	1	Stuffing Box	479	479SS6	479		
10	1	Packing Follower	482SS6	482SS6	482SS6		
11	1	O-Ring *	156	156	156		
12	1	Cage	1981	1981SS6	1981		
13	1	Trim Set	1/4"	Linear	T1202	T1202SS6	----
				Snap	T1463	----	----
			3/8"	Linear	T1234	T1234SS6	----
				Snap	T1462	----	----
			1/2"	Linear	T1977	T1977SS6	----
				Snap	T5325	----	----
Repair Kits			RFA	RFA	RFA		
Stuffing Box Assemblies		Order Code	EAV	EAVSS6	EAV		
		Max W.P. psig	6000	6000	6000		

* These parts are recommended spare parts and are stocked as repair kits.

All Pictures shown are for illustration purpose only. Actual product may vary due to product enhancement.

APPLICATIONS:

Three-Way Valves provide a convenient means for diverting flow from one pipeline to another, for bypass applications where part or all of the fluid passing through the valve is diverted through either or both of the outlets, or as a mixing valve for combining two fluid streams and discharging them through a common outlet port.

FEATURES:

- Compact design
- Valve travel indicator
- Teflon-packed stuffing box

CERTIFICATIONS:

Kimray is an ISO 9001- certified manufacturer.

HPCV 3-WAY Model CVW

For dividing flow into two directions, with the ability to seal off flow in one or the other direction.

SPLITTER VALVE Model CVD

For splitting flow into two directions, but not for sealing off in either direction.

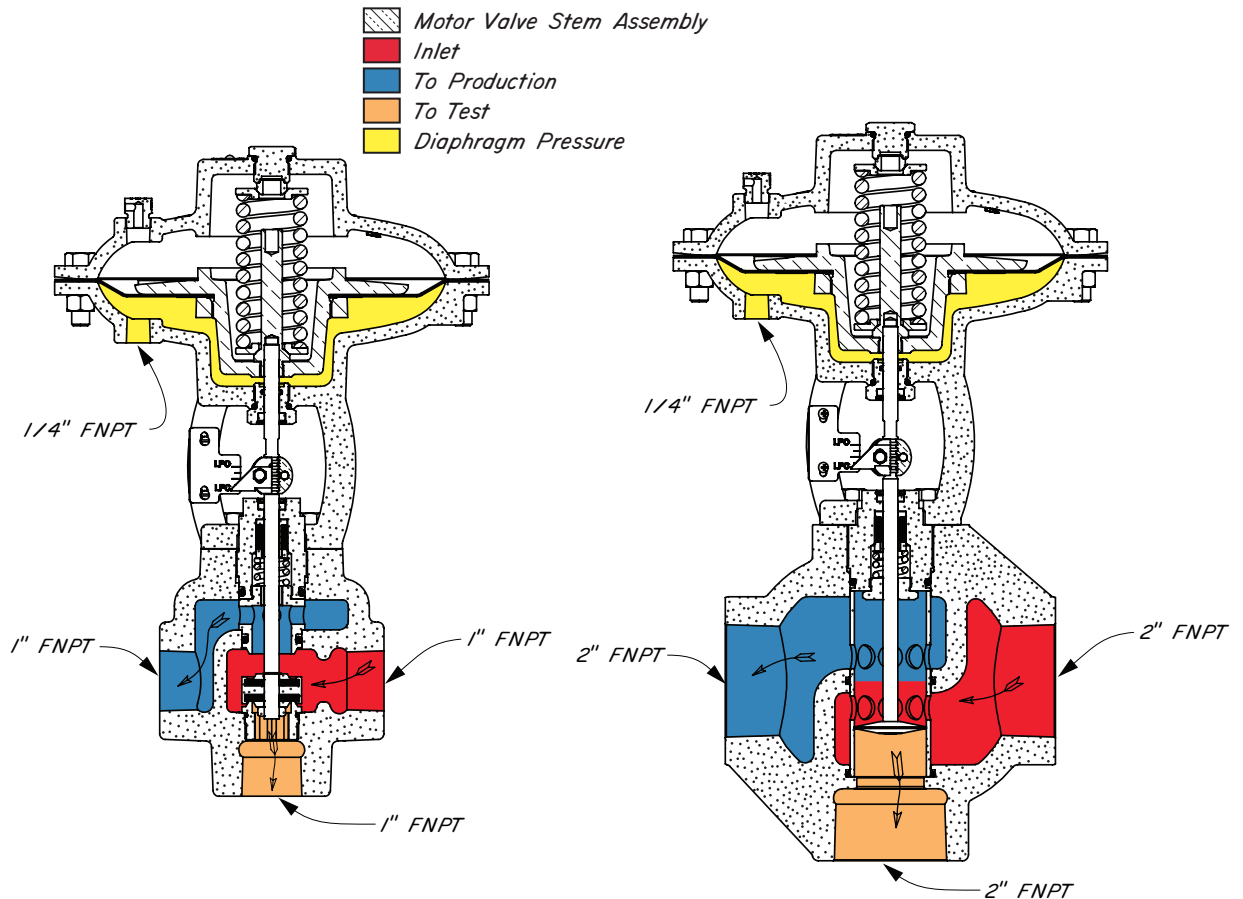

Order Code †	Series	Line Size	Connection Type	Max Δ P	Max. W.P. psig †††	Cv Upper Port	Cv Lower Port	Cf
ESEBW	CVW	1"	NPT	3000	3000	8.3	13.8	0.70
ESIBW	CVD	2"	NPT	3000	3000	27.7	38.1	0.70
ESHBW			WELD					

NOTES:

For standard & optional seals, metals, Cf Cv values & material specification see technical data on pages 01:1 - 01:X1

† Bottom Works only. For complete valve codes see page 01:300.4

††† Max W.P. values based on -20°F to 100°F.

HIGH PRESSURE CONTROL VALVES



HIGH PRESSURE 3 WAY MODEL CVW BOTTOM WORKS DRAWING

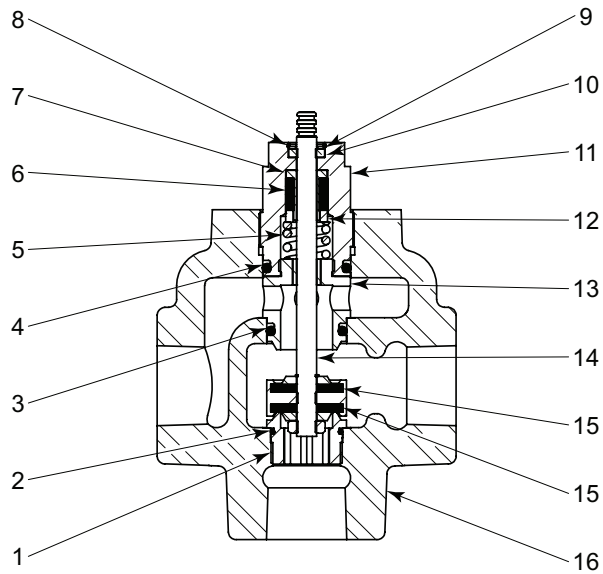

ITEM	QTY.	DESCRIPTION	PART NO
1	1	Lower Seat	2130
2	1	O-Ring *	2131
3	1	O-Ring *	156
4	1	O-Ring *	606
5	1	Spring	465
6	4	Packing Ring *	484
7	1	Packing Sleeve *	485
6&7	1	Optional VEE Packing 450°F max	5117
8	1	Snap Ring *	938
9	1	Retainer	486
10	1	Felt Wiper *	480
11	1	Stuffing Box	2127
12	1	Packing Follower	482SS6
13	1	Cage & Upper Seat	2128
14	1	Stem Assembly *	2129
15	2	Seat	2129B
16	1	Body	2126
Repair Kits			RFC
* These parts are recommended spare parts and are stocked as repair kits.			

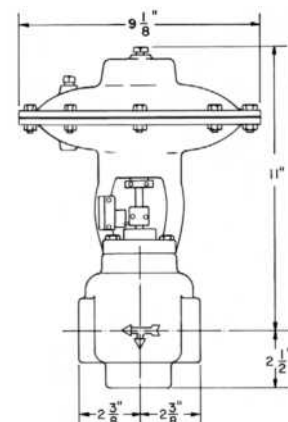

All Pictures shown are for illustration purpose only. Actual product may vary due to product enhancement.

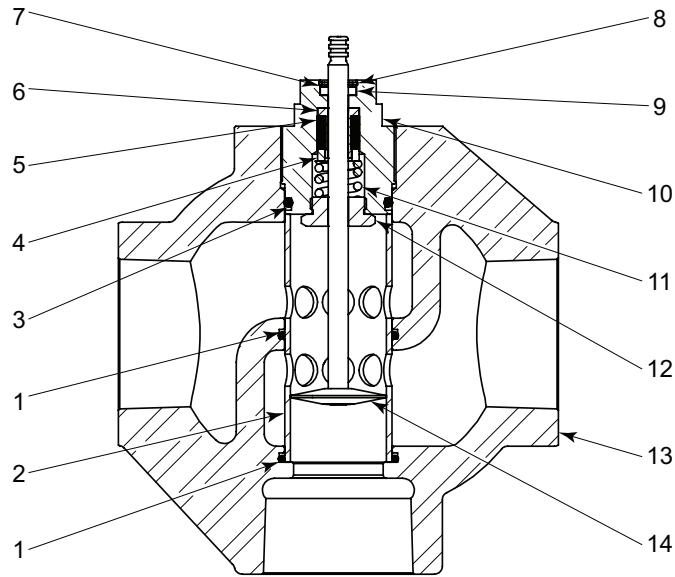

ITEM	QTY.	DESCRIPTION	PART NO
1	2	O-Ring *	2937
2	1	Cage	2933SS6
3	1	O-Ring *	2936
4	1	Follower	482SS6
5	4	Packing Ring *	484
6	1	Packing Sleeve *	485
5&6	1	Optional VEE Packing 450°F max	5118
		Optional Grafoil Packing 450°F max	5118GF
7	1	Retainer	486
8	1	Snap Ring *	938
9	1	Felt Wiper *	480
6	1	Stuffing Box	2934
11	1	Spring	465
12	1	Nut	1828
13	1	Body	
		2" NPT	2939
		2" Socket Weld	2935
		2" 6000 lb. Socket Weld	4330
14	1	Stem	2932
Repair Kits			RRG

* These parts are recommended spare parts and are stocked as repair kits.

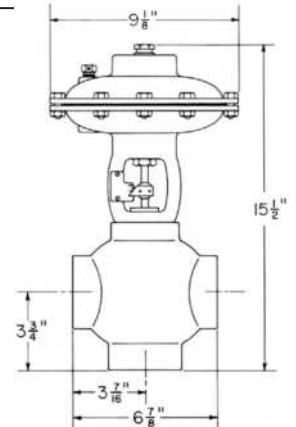

All Pictures shown are for illustration purpose only. Actual product may vary due to product enhancement.

NOTES:



Kimray is an ISO 9001- certified manufacturer.

APPLICATIONS:



Used for actuating HPCV Control Valves.

FEATURES:

- Compact design
- Valve travel indicator
- Field-reversible topworks
- Top Adjusting Screw may be adjusted to vary the spring tension slightly; this affects pressure required to actuate valve.

CERTIFICATIONS:

Kimray is an ISO 9001- certified manufacturer.

 Control Valve Diaphragm Assembly
 Control Valve Diaphragm Pressure

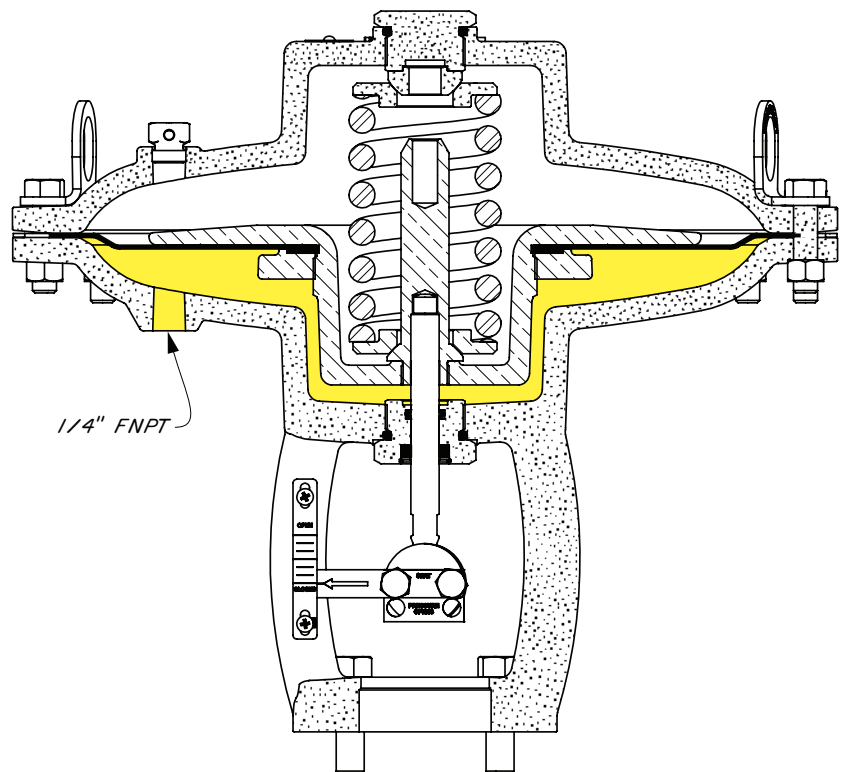

Order Code †	Body Size	Effective Diaphragm Area	Normal Actuator. W.P. psig ††	MAX. Actuator. W.P. psig ††	Stem Travel		
EAT	1"	30 square inches	10 - 30 (see spring ranges)	45	1/2"		
EBT	2"	65 square inches			3/4"		
EFX	3"	100 square inches			1 3/8"		
EEY	4"				1 3/4"		
EEZ	6"	120 square inches					2 1/2"
	8"						
	10"						

NOTES:

For standard & optional seals, metals, Cf Cv values, material specifications & dimensions see technical data on pages 01:1 - 01:XI

† Top Works only. For complete valve codes see pages 01:300.1 - 01:300.4

†† Max W.P. values based on -20°F to 100°F.

HIGH PRESSURE CONTROL VALVES

STANDARD PISTON BALANCED / CAGE GUIDED ACTUATORS PARTS DRAWING

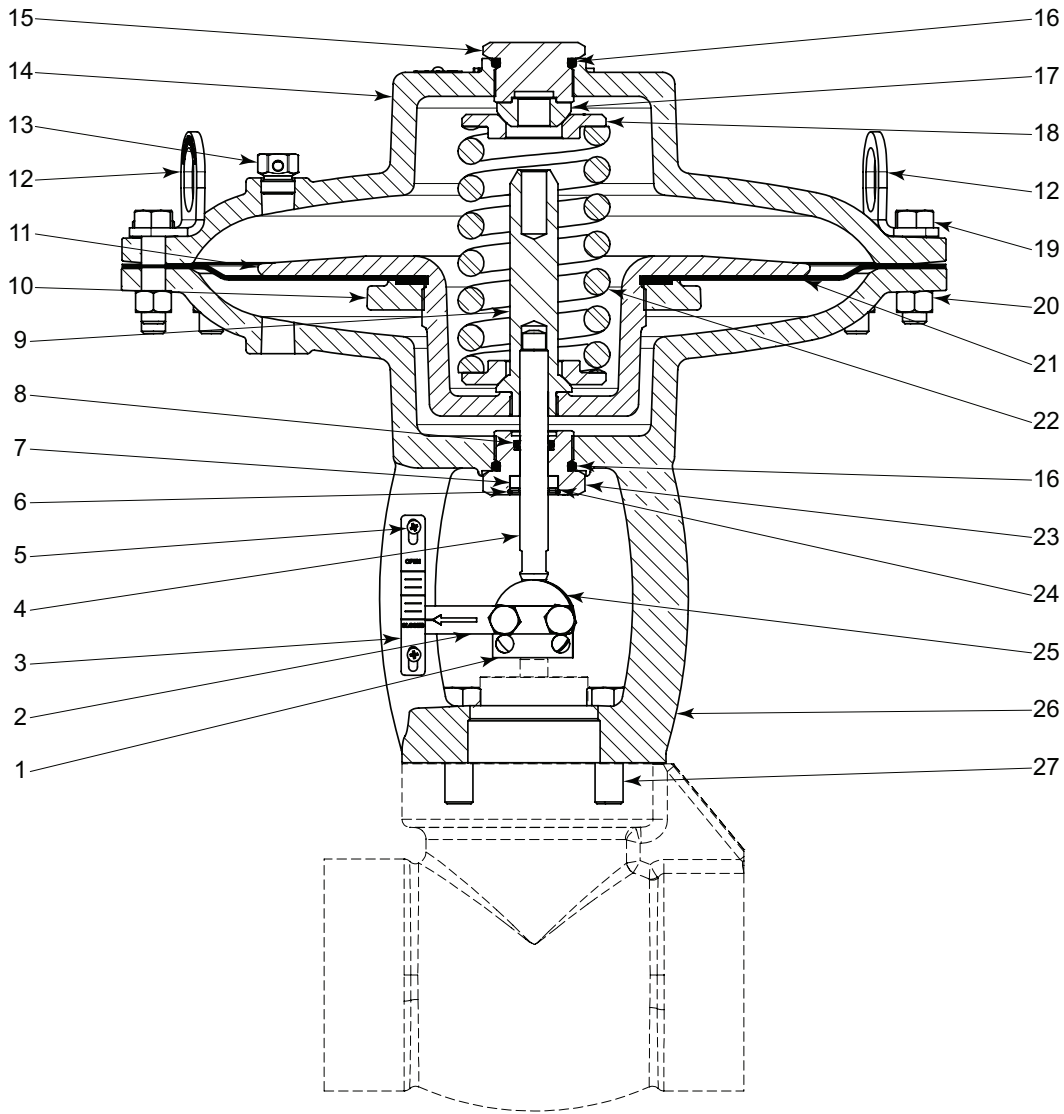



HIGH PRESSURE CONTROL VALVES

STANDARD PISTON BALANCED / CAGE GUIDED ACTUATORS PARTS LIST

ITEM	QTY.	DESCRIPTION	STANDARD PART NO.					
			1 INCH	2 INCH	3 INCH	4 INCH	6 INCH	8 & 10 INCH
1	1	Tag	----	677	4975		5352	
2	1	Travel Indicator	1659A	535	4974		5317	
3	1	Indicator Scale	488	536	4973	5131	5316	
4	1	Upper Stem	1643	522	4971	5171	5310	
5	2	Screw	7534					
6	1	Snap Ring *	938	940	4968		5311	
7	(QTY)	Felt Wiper *	480	527 (1)	4969 (2)		5337 (2)	
8	1	O-Ring *	153	530	155		5355	
9	1	Pivot Sleeve	466	510	4963	5179	5309	
10	1	Retainer Ring	476	4356	4965		5344	
11	1	Diaphragm Plate	469	4357	4964		5343	
12	2	Lifting Ring	----	7559	----			
13	1	Breather Plug	147				5559SS6	
14	1	Bonnet	461	506	4956		5299	
15	1	Upper Adjusting Screw	457	502	4959	6560	5348	
16	2	O-Ring *	491	537	808		2632	
17	1	Pivot	459	504	4960		5349	
18	2	Spring Plate	462	507	4961		5350	
19	(Qty)	Bolt	247 (10)	430 (16)	236 (24)		191 (24)	
20	(Qty)	Nut	241 (10)	241 (16)	241 (24)			
21	1	Diaphragm	475	519	5169		5315	
22	1	Spring 2-10 lb	621 (silver)	----	----	----	----	
		Spring 3-15 lb	7659 (blue)	1245 (silver)	----	----	----	
		Spring 4-20 lb	463 (red)	538 (red)	----	----	----	
		Spring 6-30 lb	464 (green)	508 (yellow)	4962	5130 (red)	5353 / 5314 ‡	
		Spring 9-45 lb	----	6848 (blue)	----	----	----	----
23	1	Lower Adjusting Screw	458	503	4967		5351	
24	1	Retainer	486	528	4970		5338	
25	1	Coupling Block	1659	511	4972		5345	
26	1	Yoke	460	505	4957		5300	
27	4	Bolt	694	524	4991		5406	
Repair Kits			RHV	RHW	RYB		RWDTW	
Actuator Assembly	Fail Close	2-10 lb Spring	EASPO10	----	----	----	----	
		3-15 lb Spring	EASPO15	EBTPO15	----	----	----	
		4-20 lb Spring	EASPO20	EBTPO20	----	----	----	
		6-30 lb Spring	EASPO30	EBTPO30	EFXPO30	EEYPO30	EEZPO30	
		9-45 lb Spring	----	EBTPO45	----	----	----	
	Fail Open	2-10 lb Spring	EASPC10	----	----	----	----	
		3-15 lb Spring	EASPC15	EBTPC15	----	----	----	
		4-20 lb Spring	EASPC20	EBTPC20	----	----	----	
		6-30 lb Spring	EASPC30	EBTPC30	EFXPC30	EEYPC30	EEZPC30	
		9-45 lb Spring	----	EBTPC45	----	----		
			* These parts are recommended spare parts and are stocked as repair kits.					
			‡ 5314 on Pressure Open only					

STANDARD STEM GUIDED / CAGE GUIDED ACTUATOR CONVERSION INSTRUCTIONS

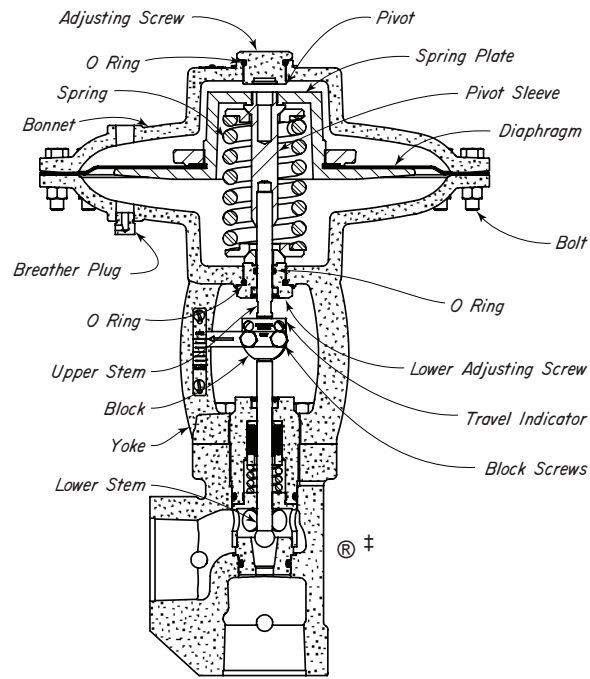
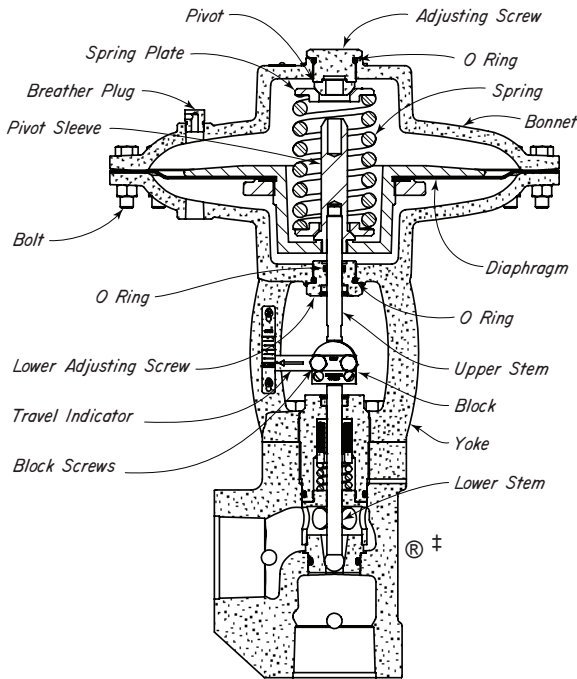

PRESSURE CLOSING to PRESSURE OPENING:

Remove BLOCK SCREWS, TRAVEL INDICATOR and COUPLING BLOCK. Remove UPPER ADJUSTING SCREW, BOLTS, and BONNET. Lift out Diaphragm Assembly (Crosshatched). Remove SPRING, SPRING PLATES and PIVOT. Unscrew UPPER STEM and insert in opposite end of PIVOT SLEEVE.

Replace LOWER ADJUSTING SCREW and tighten against YOKE. O RING 491 - 1", 537 - 2", provides the necessary pressure seal. Invert Diaphragm Assembly and replace. Care should

be taken when threading the UPPER STEM through the LOWER ADJUSTING SCREW so as not to damage O RING, 153Q - 1", 530Q - 2". Replace SPRING with a SPRING PLATE in each end. UPPER ADJUSTING SCREW opening Thread UPPER ADJUSTING SCREW into BONNET until contact is made with the PIVOT, then tighten two turns. The UPPER ADJUSTING SCREW now becomes the SPRING adjustment. With BLOCK SCREWS through INDICATOR, replace COUPLING BLOCK matching match marks. Move BREATHER PLUG to BONNET (upper Diaphragm Housing). Connect Diaphragm Pressure from PILOT to YOKE (Lower Diaphragm Housing).

PRESSURE OPENING to PRESSURE CLOSING:

Remove BLOCK SCREWS, TRAVEL INDICATOR and COUPLING BLOCK. Remove UPPER ADJUSTING SCREW, BOLTS, and BONNET. Lift out Diaphragm Assembly (Crosshatched). Remove SPRING, SPRING PLATES and PIVOT. Rotate Diaphragm Assembly when pulling UPPER STEM through LOWER ADJUSTING SCREW so as not to damage O-Ring, 153Q - 1", and 530Q - 2".

Unscrew UPPER STEM and replace in opposite end of PIVOT SLEEVE.

Using COUPLING BLOCK, pull LOWER STEM up to open position. Thread LOWER ADJUSTING SCREW in YOKE until end is flush with inside surface of YOKE. Set PIVOT on top of LOWER ADJUSTING SCREW with the beveled surface up. Replace SPRING with a SPRING PLATE in each end.

Invert Diaphragm Assembly from its original position and replace. Be sure UPPER STEM and LOWER STEM meet. With BLOCK SCREWS through INDICATOR, replace COUPLING BLOCK matching match marks. Replace BONNET and BOLTS and INDICATOR is in "Open" position, then tighten one turn. Move BREATHER PLUG to YOKE (Lower Diaphragm Housing). Connect Diaphragm Pressure from PILOT to BONNET (Upper Diaphragm Housing).

APPLICATIONS:

Allows a wider spring adjustment range for discharge of liquid or gas from vessels, separators, treaters, knockouts and similar liquid accumulators.

Allows a finer control when used with back pressure and pressure reducing controllers.

Used as an operator on 1" HPCV, 2" HPCV or 1" SMS.

FEATURES:

Compact design

Valve travel indicator

All steel

Adjustable topworks

Top Adjusting Screw may be adjusted to vary the spring tension slightly; this affects pressure required to actuate valve.

CERTIFICATIONS:

Kimray is an ISO 9001- certified manufacturer.

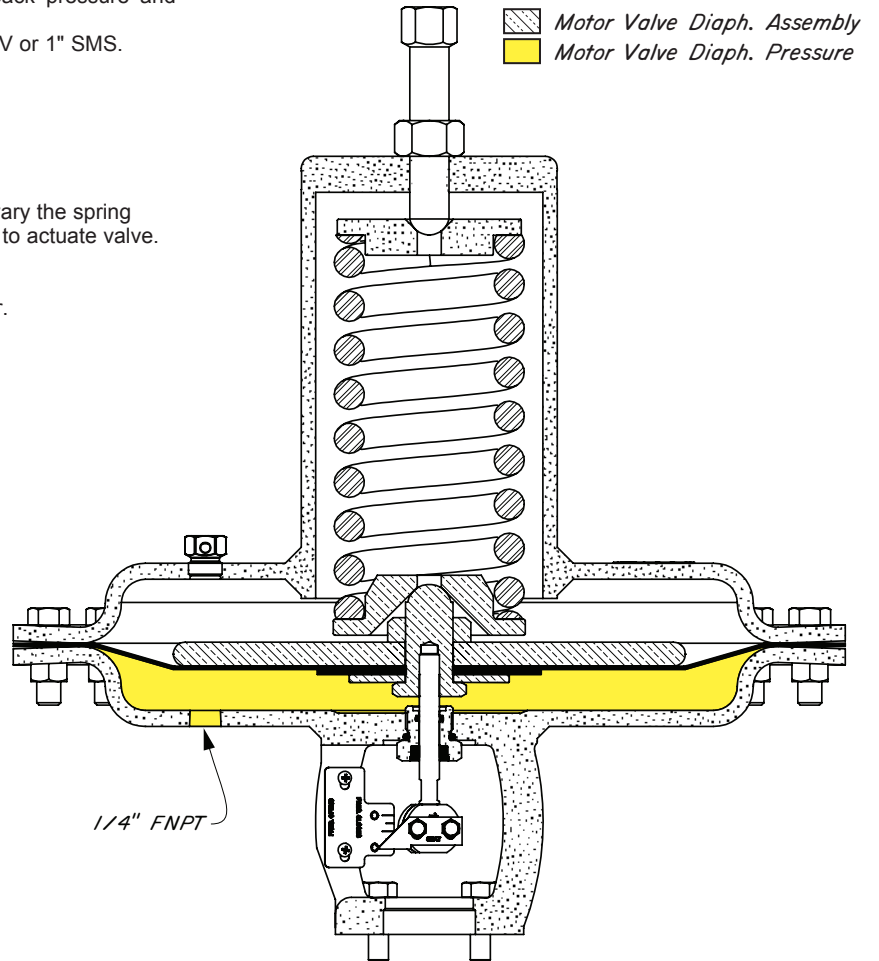

Order Code †	Body Size	Effective Diaphragm Area	Spring Diaphragm Pressure psig ††	Normal Actuator. W.P. psig ††	MAX. Actuator. W.P. psig ††	Stem Travel
EAU	1"	65 square inches	10 - 30	25	45	3/4" MAX
EBW	2"					

NOTES:

For standard & optional seals, metals, Cf Cv values, material specifications & dimensions see technical data on pages 01:I - 01:XI

† Top Works only. For complete valve codes see page 01:300.4

†† Max W.P. values based on -20°F to 100°F.

HIGH PRESSURE CONTROL VALVES



-65 ACTUATORS MODEL CVS PARTS DRAWING

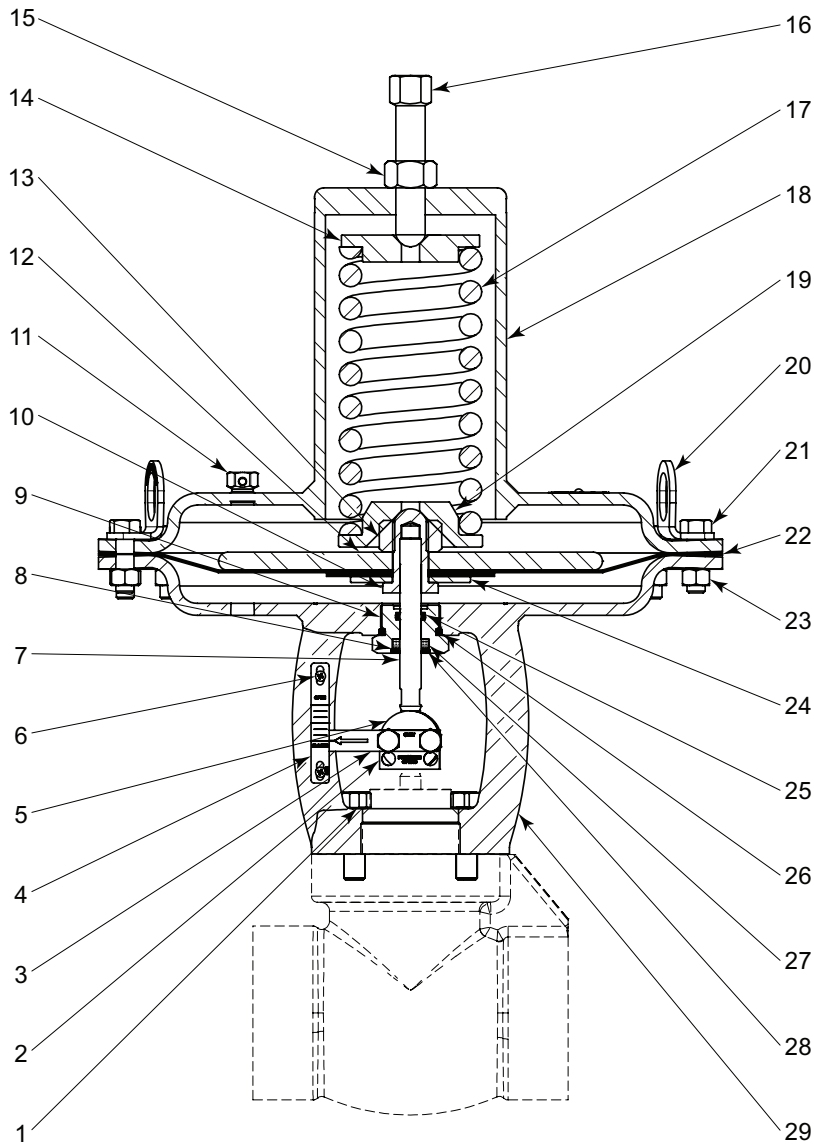

ITEM	QTY.	DESCRIPTION	STANDARD PART NO.	
			1 INCH	2 INCH
1	4	Bolt	845	524
2	1	Tag	----	677
3	1	Travel Indicator	1659A	535
4	1	Indicator Scale	488	536
5	1	Coupling Block	1659	511
6	2	Screw	7534	
7	1	Upper Stem	1643	522
8	1	Retainer	486	528
9	1	Lower Adjusting Screw	458	503
10	1	Pivot Screw	2237	1986
11	1	Breather Plug	147	
12	1	Diaphragm Plate	1890	
13	1	Lock Nut	175	
14	1	Upper Spring Guide	1888	
15	1	Nut	1897	

ITEM	QTY.	DESCRIPTION	STANDARD PART NO.	
			1 INCH	2 INCH
16	1	Adjusting Screw	1987	
17	1	Spring	1848	
18	1	Bonnet	1886	
19	1	Lower Spring Guide	1889	
20	2	Lifting Ring	----	7559
21	16	Bolt	247	
22	1	Diaphragm	1892	
23	16	Nut	241	
24	1	Lower Diaphragm Plate	1893	
25	1	O-Ring	*	153
26	1	O-Ring	*	491
27	(QTY)	Felt Wiper	*	480
28	1	Snap Ring	*	938
29	1	Yoke	1887	1989
Repair Kits			RHV	RHW

* These parts are recommended spare parts and are stocked as repair kits.

All Pictures shown are for illustration purpose only. Actual product may vary due to product enhancement.

METERING VALVE MODEL CVS & CVC

APPLICATIONS:

This valve can be used to meter or control flow of liquids and/or gases on meter runs, flow lines, or may be used as a choke under low pressure drop conditions where freezing is not a problem.

FEATURES:

- Compact design
- O-Ring sealed seat
- Teflon-packed stuffing box
- Easily adjusted
- Large adjusting knob

CERTIFICATIONS:

Canadian Registration Number (CRN):
 0C15021.24567890NTY (1 & 2" HPCV MV)
 0C10903.24567890NTY (2" HPCV PB MV)
 0C15019.24567890NTY (3" HPCV PB MV)
 Kimray is an ISO 9001- certified manufacturer.

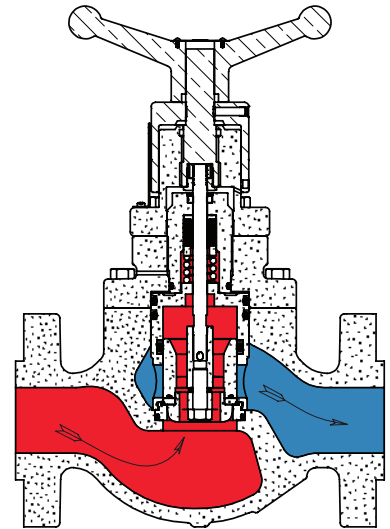
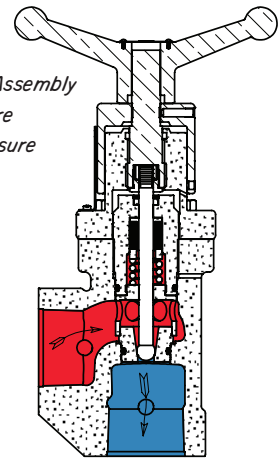
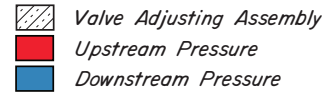

Order Code †	Body Size	Description	Required turns to open	Opening Graduated	Stem Travel
See page 01:300.3	1"	Metering Valve Top Works	6	64ths	1/2"
	2"				3/4"
	3"				1 3/8"

NOTES:

For standard & optional seals, metals, Cf Cv values, material specifications & dimensions see technical data on pages 01:I - 01:X1

† Bottom Works only. For complete valve codes see page 01:300.3

HIGH PRESSURE CONTROL VALVES



METERING VALVE MODEL CVS & CVC PARTS DRAWING

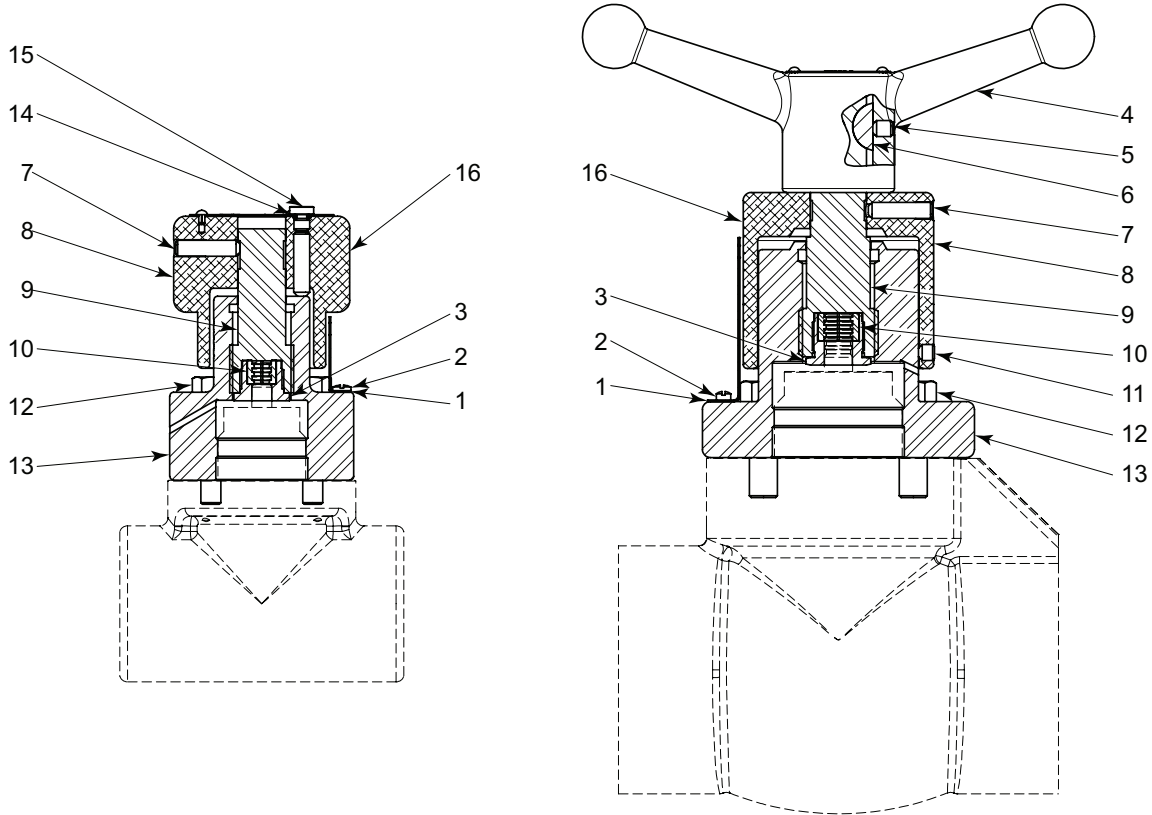

ITEM	QTY.	DESCRIPTION	STANDARD PART NO.			
			1 INCH	2 INCH	3 INCH	
1	1	Indicator Plate	2867	5040		
2	2	Screw	2574			
3	1	Stem Nut	2866	2885	5037	
4	1	Handle	----	5034		
5	1	Set Screw	----	5042		
6	1	Keyway	----	5052		
7	(Qty)	Set Screw	2879 (3)	2879 (1)		
8	1	Adjusting Knob	2862	6863	5038	
9	1	Adjusting Screw	2864	6862	5035	
10	2	Keeper	2865	2884	5036	
11	1	Set Screw	----	6885	----	
12	4	Bolt	2869	524	2142	
13	1	Bonnet	2868	2888	5041	
14	1	O-Ring	2881	----		
15	1	Plug	2880	----		
16	1	Indicator Label	1/4"	4727	----	
			1/2"	4728	----	
			28/64"	----	2876	----
			40/64"	----	2877	----
			54/64"	----	2878	----
			2"	----	4938	----
		3"	----	----	5039	
Repair Kits		Stem Guided	RSH	RSE	----	
		Cage Guided	----	RSN	RSO	

All Pictures shown are for illustration purpose only. Actual product may vary due to product enhancement.

APPLICATIONS:

Utilizes (any) quarter-turn actuator with ISO-5211 connection in conjunction with Kimray HPCV. To control level, flow, pressure, temperature of process fluid.

FEATURES:

- Open-yoke design
- Standard coupling block and mounting hardware to valve
- Weather-tight, maintenance-free design

CERTIFICATIONS:

Kimray is an ISO 9001- certified manufacturer.

CONNECTIONS:

- R2L-1: ISO F05, 14MM SQ
- R2L-2: ISO F07, 14MM SQ

VALVCON ROTARY ACTUATOR (KSRADCWX):

- ON/OFF and Modulating control
- Power input is UNIVERSAL
 - 12/24VDC
 - 24VAC
 - 115/230VAC
- CL I, Div. 1 Explosion Proof Enclosure
- 100% duty cycle
- Battery backup included for fail-safe operation
 - Configurable for fail open, closed or position
 - Park or Continue operation upon power loss
- Inputs
 - 4-20mA
 - 0-10V
 - Resistive control
 - On/off – 2 & 3 wire control
- Feedback
 - Limit switches
 - 0-10V or 4-20mA
 - Battery monitor
- Integral heater for condensation and battery protection
- Options
 - Modbus RS485
 - Handwheel for manual override

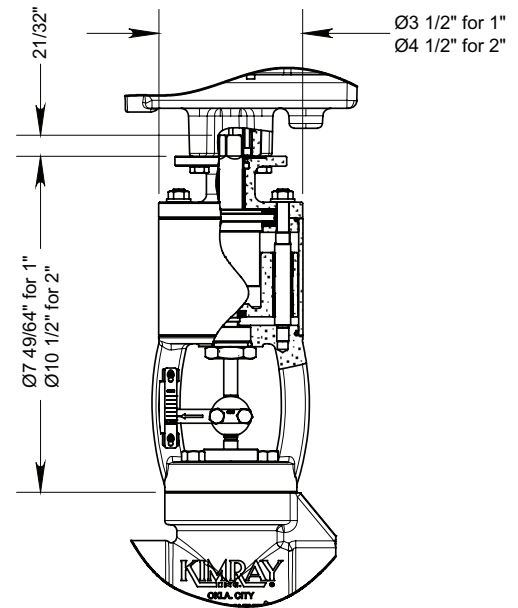

OPERATION:

Spiral rotation of the ROTARY SHAFT by means of a rotary actuator is translated into linear motion, opening and closing the valve. The stroke length is achieved with 90° rotation of the shaft, clockwise to close. As the plug contacts the seat, a series of springs become loaded to ensure valve closure in the event of seat creep or wear.



ADAPTERS						
Order Code	Description	Line Size	ISO 5211	Shaft		
YHN	R2L-1	1"	F05	14mm SQ		
YHO	R2L-2	2"	F07	14mm SQ		
ELECTRIC ACTUATORS AVAILABLE						
Order Code	Description	Voltage	ISO 5211	Torque		
KSRADCWX	VALVCON ADC	MULTI	F05/07	600in lb		
		230VAC	115VAC	24VAC	24VDC	12VDC
	CYCLE TIME (SEC/90°)	14	14	13	13	17
	CURRENT DRAW (AMPS)	0.5	0.6	2.5	1.7	2.8
NOTES:						
For standard & optional seals, metals, Cf Cv values, material specifications & dimensions see technical data on pages 01:I - 01:XI						

All Pictures shown are for illustration purpose only. Actual product may vary due to product enhancement.

HIGH PRESSURE CONTROL VALVES



R2L ACTUATOR / ADAPTOR PARTS DRAWING

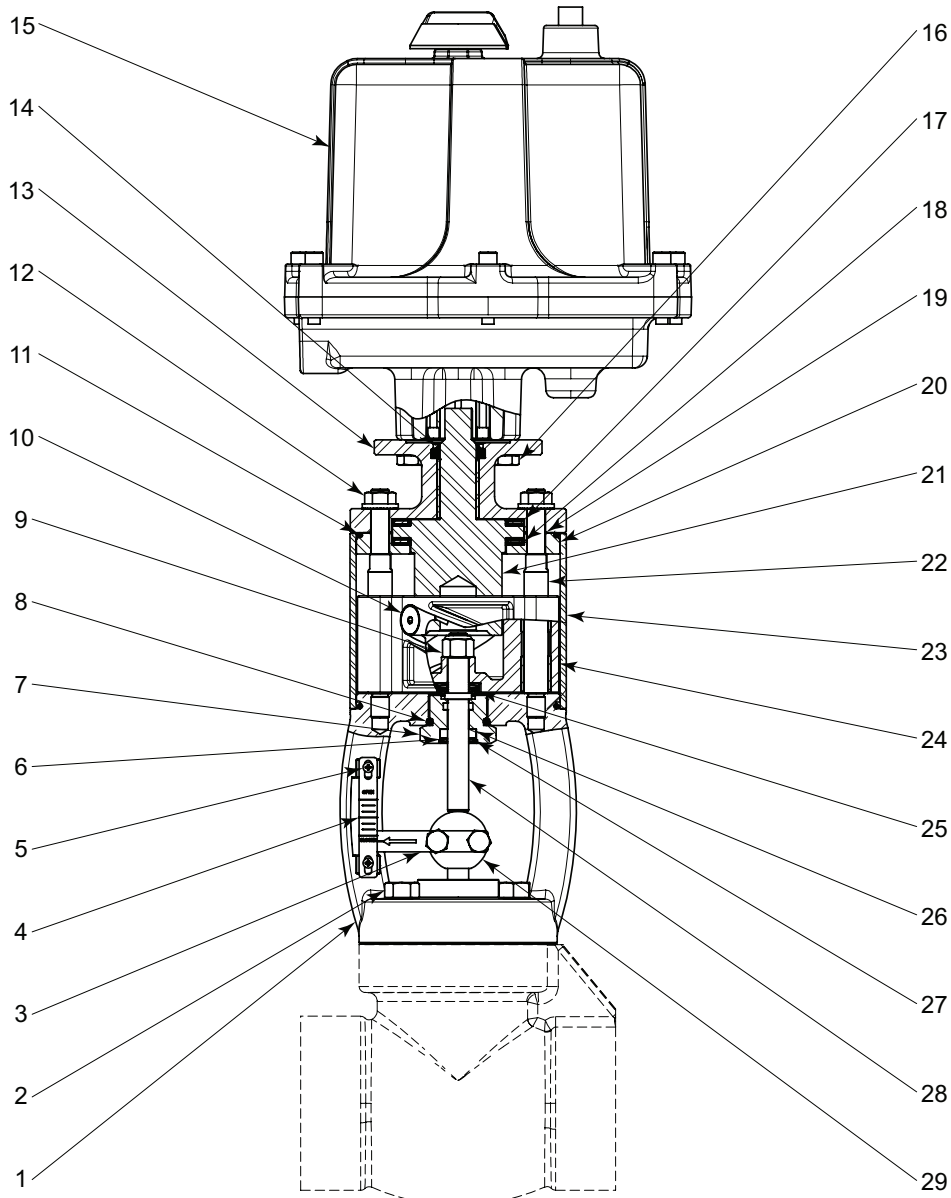

ITEM	QTY.	DESCRIPTION	STANDARD PART NO.	
			1 INCH	2 INCH
1	1	Mounting Yoke	7377	7390
2	4	Bolt	694	524
3	1	Travel Indicator	1659A	535
4	1	Indicator Scale	488	536
5	2	Screw	7534	
6	1	Retainer	486	528
7	1	Lower Adjusting Screw	458	503
8	1	O-Ring *	491	537
9	1	Nylon Lock Nut	7366	7378
10	2	Cam Follower *	7383	7381
11	2	O-Ring *	7425	4238
12	4	Lock Nut	7364	7374
13	1	Flange Adapter	7384	7391
14	1	Rod Wiper *	7370	
15	1	Actuator (Sold Separately)	KSRADCWX	

ITEM	QTY.	DESCRIPTION	STANDARD PART NO.	
			1 INCH	2 INCH
16	4	Screw	7373	7380
17	4	Bearing Race *	7362	7369
18	2	Bearing *	7361	7368
19	4	O-Ring *	7511	7508
20	1	Bearing Support	7388	7395
21	1	Rotary Shaft	7385	7392
22	4	Guide Rod	7387	7394
23	1	Dust Cover	7389	7396
24	1	Stem Carrier	7382	7393
25	(Qty.)	Disc Spring	7363 (3)	7371 (4)
26	1	Wiper *	480	527
27	1	Snap Ring *	938	940
28	1	Stem	7386	7397
29	1	Coupling Block	1659	511
Repair Kits			RXD	RXE

All Pictures shown are for illustration purpose only. Actual product may vary due to product enhancement.

APPLICATIONS:

- Used on 2" HPCV's.
- For closing valves manually when there is pressure on the diaphragm.
- For limiting valve stem travel in the opened or closed direction.

FEATURES:

- Compact design
- Valve travel indicator
- Adjustable topworks
- Sealed bearings

TOPWORKS:

- MVP's are furnished with a spring designed for 30 psig diaphragm pressure.

CERTIFICATIONS:

Kimray is an ISO 9001- certified manufacturer.

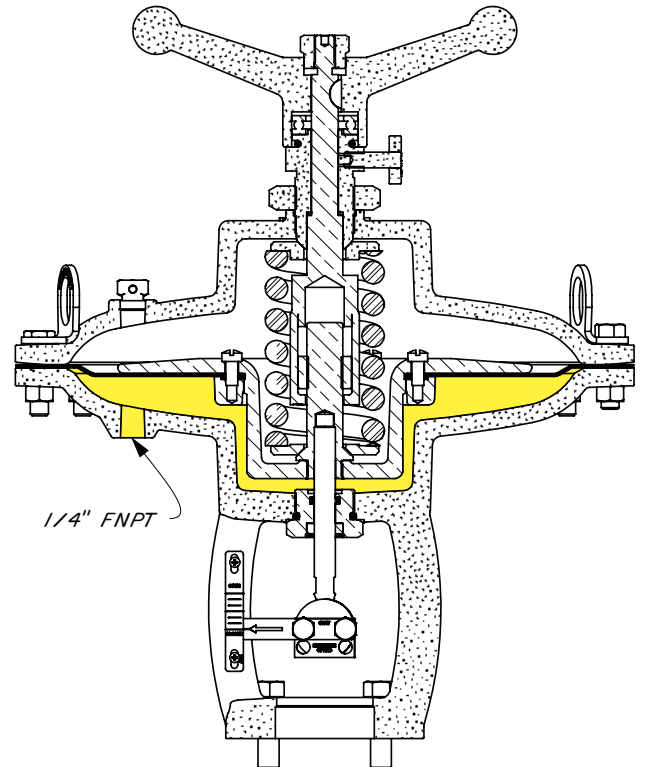

Order Code †	Body Size	Control Range psig	Output Press psig	Max. W.P. psig †
EBX	2 inch	6 - 30	45	45

NOTES:

For standard & optional seals, metals, Cf Cv values, material specifications & dimensions see technical data on pages 01:I - 01:X1

†† Max W.P. values based on -20°F to 100°F.

MANUAL VALVE POSITIONER MANUAL VALVE POSITIONER SERIES PARTS DRAWING

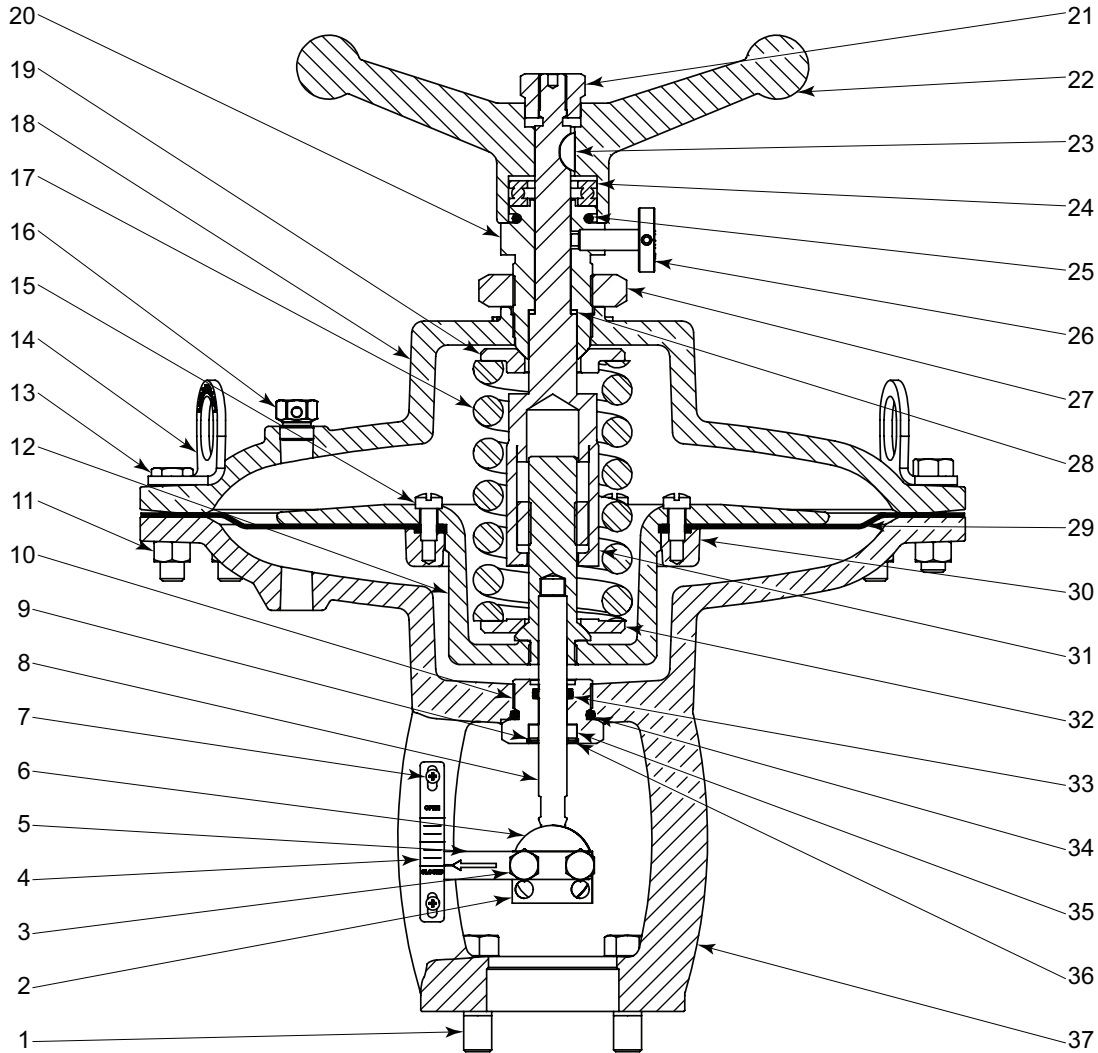

ITEM	QTY.	DESCRIPTION	PART NO. 2 INCH
1	4	Bolt	524
2	1	Tag	677
3	2	Screw	512
4	1	Indicator Scale	536
5	1	Travel Indicator	535
6	1	Coupling Block	511
7	2	Screw	7534
8	1	Stem	522
9	1	Retainer	528
10	1	Lower Adjusting Screw	503
11	16	Nut	241
12	1	Diaphragm Plate	2909
13	16	Bolt	430
14	2	Lifting Ring	7559
15	6	Screw	523
16	1	Breather Plug	147
17	1	Spring	508
18	1	Bonnet	506
19	1	Spring Plate	507

ITEM	QTY.	DESCRIPTION	PART NO. 2 INCH
20	1	Adjusting Screw	1839
21	1	Lock Nut	1838
22	1	Handle	1835
23	1	Key	1845
24	1	Thrust Bearing	1843
25	1	O-Ring	* 156
26	1	Lock Screw w/Nylon Seat	1844
27	1	Lock Nut	1841
28	1	Thrust Washer	* 1846
29	1	Diaphragm	6779
30	1	Ring	521
31	1	Position Shaft Assembly	1842
32	1	Spring Plate	2173
33	1	O-Ring	* 530
34	1	O-Ring	* 537
35	1	Wiper	* 527
36	1	Snap Ring	* 940
37	1	Yoke	505
Repair Kits			RFH

All Pictures shown are for illustration purpose only. Actual product may vary due to product enhancement.

APPLICATIONS:

For Kimray Control Valves with the Kimray TRITEX II:

- Flow control valve
- Pressure control upstream/downstream/differential
- Choke valve
- Compressor controls
- Gas lift valve
- Dump valve

CERTIFICATIONS:

Kimray is an ISO 9001- certified manufacturer.

FEATURES:

Voltage	12-48 VDC
I/O	4/3 isolated digital 1/1 isolated 4-20 mA
Rating	Class 1, Division 2, Groups A,B,C & D
Connection	1/2" NPT
Temp	-40° F to 149° F (-40° C to 65° C)
Force	Continuous to 872 lbf Peak to 1190 lbf
Stroke	3" max
Speed	up to 5 in./sec.
Duty Cycle	100%
Life	100M + strokes

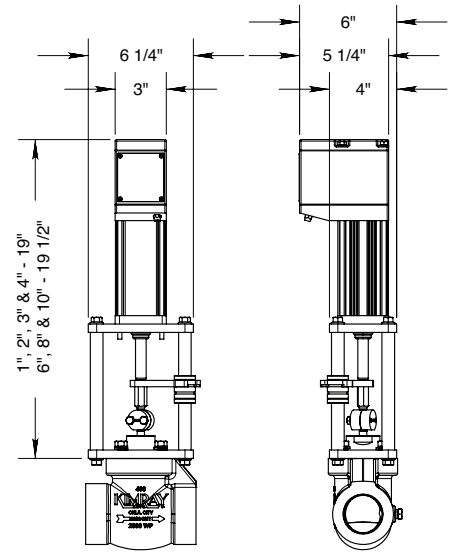

OPERATION:

The TRITEX II DC LINEAR ACTUATOR uses a roller screw attached to a servo motor to convert the rotary motion of the motor directly to a linear force. The control and positioner used in the actuator provide closed-loop feedback, eliminating the need for limit switches, torque switches or any mechanical means of feedback. The electronics provide a 4-20 mA input and output, as well as digital input and output. The result is speed, precision and a long-lasting actuator with little to no maintenance.

ELECTRIC ACTUATORS AVAILABLE		
Order Code	Description	Voltage
KSETDM0750301	TRITEX II ACTUATOR	12V-48V
MOUNTING KITS AVAILABLE		
Order Code	Description	Line Size
KSMK11EX30KITUM	TRITEX II MOUNTING KIT	1"
KSMK12EX30KITUM		2"
KSMK13EX30KITUM		3" - 4"
KSMK16EX30KITUM		6" - 10"
CABLES AVAILABLE		
Order Code	Description	Length
KSET49795	COMMUNICATION CABLE	6 FOOT
KSET49796		15 FOOT
NOTES:		
For standard & optional seals, metals, Cf Cv values, material specifications & dimensions see technical data on pages 01:I - 01:X1		

NOTES:



Kimray is an ISO 9001- certified manufacturer.

Equal Percentage Trim:

A given amount of change in stem position will make the same percent of change in flow whether the flow is low and the valve is nearly closed, or the flow volume is high and the valve is nearly open. In other words: if a 10 psi change in diaphragm pressure is required to fully travel the plug in the valve then with the valve in a specific open position, adding 1 psi to the diaphragm pressure will increase the flow by 154% of the previous value, no matter where you start. This allows for precise control at high pressure drops throughout the valve's range of position.

Application: Throttling service.

Linear "Nominal" Trim:

The characteristic could be described as "quick opening, semi-linear". Application: On / off service where abrasive material is not present in the media stream. May be used for throttling liquid service, though Equal Percentage trim would provide smoother control at higher pressure drops.

Carbide "Quick Opening" Trim:

The seat is designed so that the maximum Cv is reached with a minimal amount of closure member travel. Quick opening will have a carbide ring brazed in the bottom of the seat and the stem ball will have one lapping ring around it.

Applications: On / off service. Highly abrasive service.

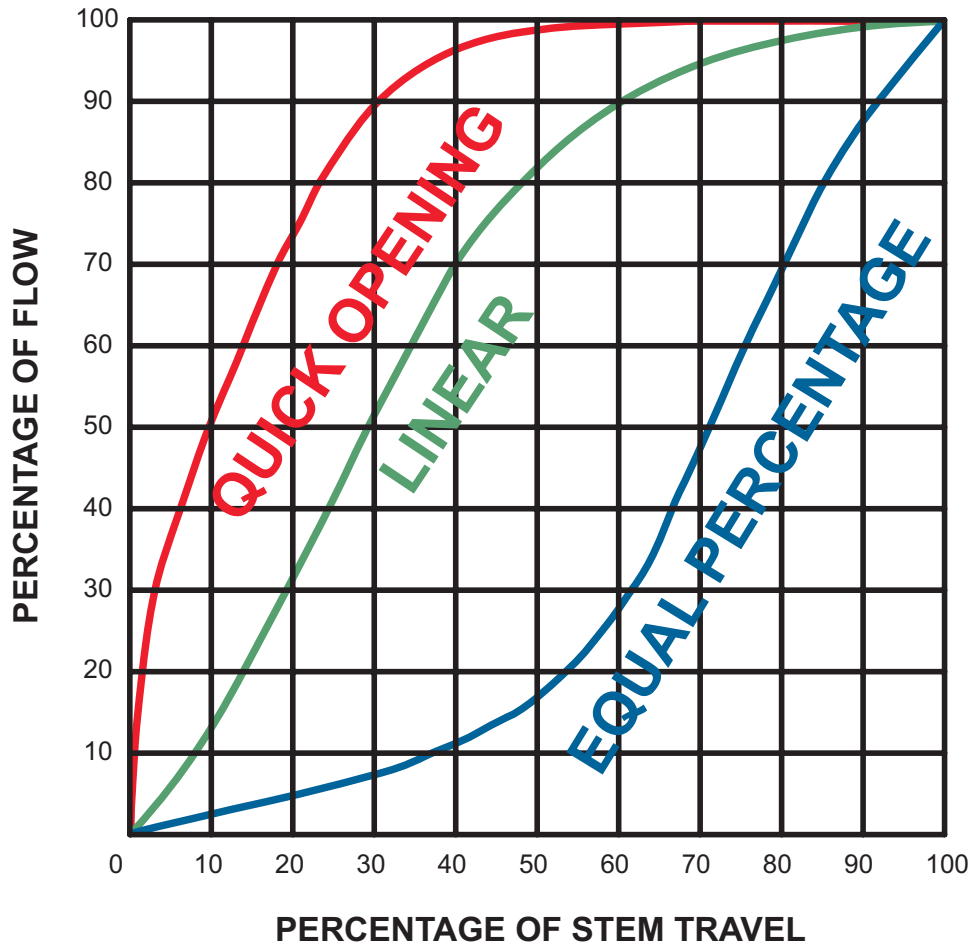
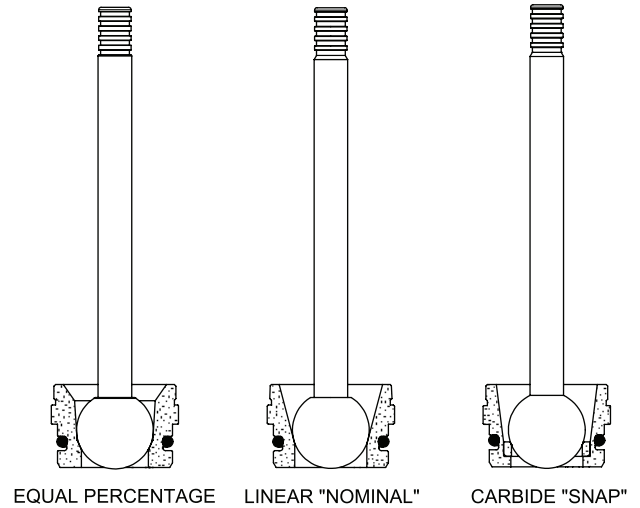

All Pictures shown are for illustration purpose only. Actual product may vary due to product enhancement.

VALVE	FLOW CHARACTERISTIC	MATERIAL	INNER VALVE SIZE					
			1/8"	3/16"	1/4"	3/8"	1/2"	
1" SMA & 1" SMT	LINEAR "NOMINAL" FLOW	TOOL STEEL* ^a	T2842	T2841	T2840	T2838	T2839	
		17-4PH ^d	T2842PH	T2841PH	T2840PH	T2838PH	T2839PH	
		316SS ^c	T2842SS6	T2841SS6	T2840SS6	T2838SS6	T2839SS6	
	EQUAL PERCENTAGE	CARBIDE "QUICK OPENING"	CARB. INSERT	T2856	T2855	T2854	T2853	T5307
			TOOL STEEL*	T6400		T4730 ^a		T4732 ^a
			316SS ^c	T6400SS6		T4730SS6		T4732SS6
		ZIRCONIA			T4730ZR		T4732ZR	
1" SMS	LINEAR "NOMINAL" FLOW	TOOL STEEL* ^a			T1202	T1234	T1977	
		316SS ^c			T1202SS6	T1234SS6	T1977SS6	
	CARBIDE "QUICK OPENING"	CARB. INSERT ^a			T1463	T1462	T5325	
1" MV	EQUAL PERCENTAGE	TOOL STEEL* ^a			T4730MV		T4732MV	
		316SS ^c			T4730SS6MV		T4732SS6MV	
		ZIRCONIA			T4730ZRMV		T4732ZRMV	
VALVE	FLOW CHARACTERISTIC	MATERIAL	INNER VALVE SIZE					
			1/4"	3/8"	1/2"	3/4"	1"	
2" SMA & 2" SMT	LINEAR "NOMINAL" FLOW	TOOL STEEL*	T2895 ^a	T2896 ^a	T2897 ^a	T2898 ^b	T2899 ^b	
		17-4PH ^d	T2895PH	T2896PH	T2897PH	T2898PH	T2899PH	
		316SS ^c		T2896SS6	T2897SS6	T2898SS6	T2899SS6	
		ZIRCONIA					T2899ZR	
	CARBIDE "QUICK OPENING"	CARB INSERT	T2890	T2891	T2892	T4690	T4691	
		ZIRCONIA		T2891ZR		T4690ZR		
VALVE	FLOW CHARACTERISTIC	MATERIAL	INNER VALVE SIZES					
			1/4"	7/16"	5/8"	7/8"	1"	
2" SMA & 2" SMT	EQUAL PERCENTAGE	TOOL STEEL*	T6404	T2993 ^a	T2992 ^b	T2947 ^b		
		17-4PH ^d	T6404PH	T2993PH	T2992PH	T2947PH		
		316SS ^c	T6404SS6	T2993SS6	T2992SS6	T2947SS6		
		ZIRCONIA		T2993ZR	T2992ZR	T2947ZR		
2" MV	EQUAL PERCENTAGE	TOOL STEEL* ^a	T6404MV	T2993MV	T2992MV	T2947MV		
		17-4PH ^d				T2947PHMV		
		316SS ^c	T6404S6MV	T2993S6MV	T2992S6MV	T2947S6MV		
		ZIRCONIA		T2993ZRMV	T2992ZRMV	T2947ZRMV		

^aCarbide ball rigidly connected to a 303SS stem
^bHardened high chrome alloy ball connected to a 303SS stem
^cOne piece 316SS steel stem
^dOne piece 17-4 PH SS steel stem
*Seat and Plug furnished with Standard HPCV

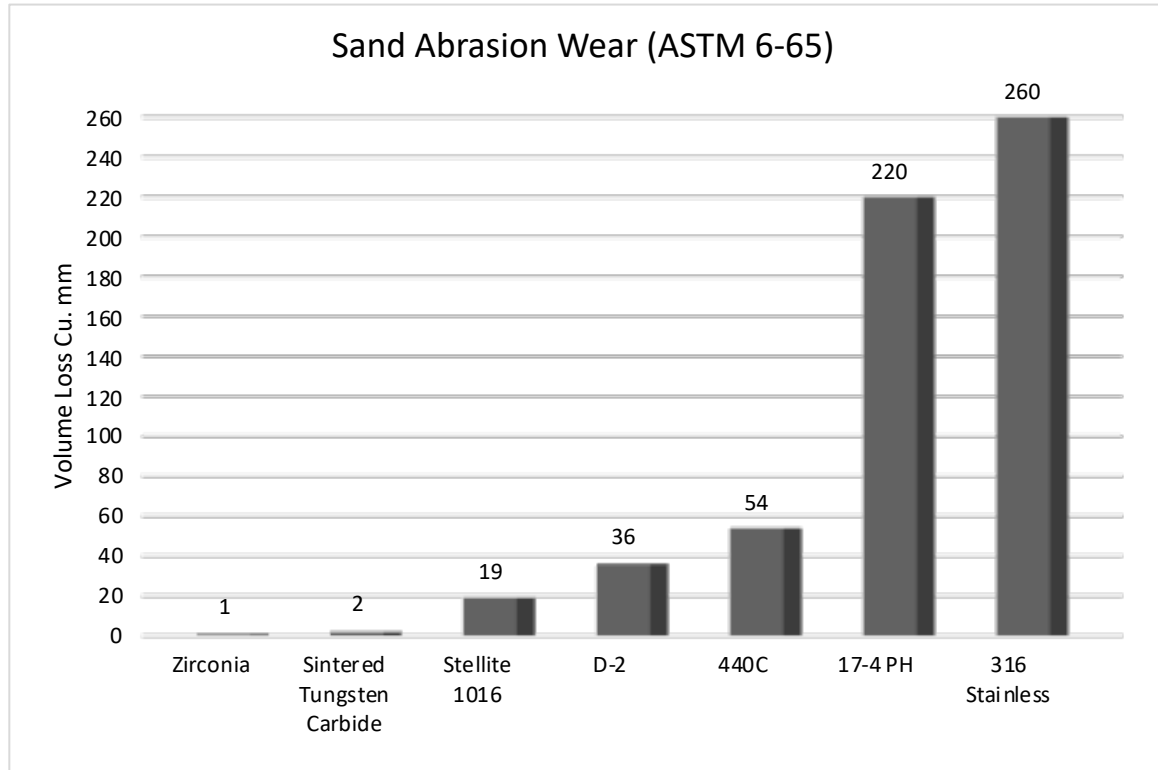

Figure 1

Valve Trim & Inner Valve Material Abrasion Resistance

The abrasion resistance of common inner valve materials varies (seat, ball, trim sets, ratio plug, piston). A standard ASTM G-65 test can be used to compare the abrasion resistance of valve plug materials using silica sand as abrasive.

In the ASTM G-65 procedure A, fine silica sand is introduced at a specified rate between the wear sample and a rubber wheel that is spinning in contact with the wear sample. The rubber wheel carries the sand across the surface of the wear sample for a specified period of time, abrading the surface. Volume loss is then calculated for the wear sample.

References

Budinski, Kenneth G., and Michael K. Budinski. *Engineering Materials: Properties and Selection*. 8th ed. Upper Saddle River, NJ: Prentice Hall, 2005. Print.

*(ASTM G-65, table x1.2 Volume Loss Range) .

NOTES:



Kimray is an ISO 9001- certified manufacturer.

Equal Percentage Trim

The Equal Percentage Trim is designed with a ratio plug shaped to produce an equal percentage of increased flow when the Equal Percentage Trim is moved in equal increments of distance. With equal percentage trim, an equal increment of change in stem position will produce an equal percent of change in Cv. For every 10% increase in valve position, the flow coefficient changes 154%, see Figure 1.

Modified Percentage Trim

Modified percentage trim is designed to achieve maximum flow at full open and precise control at the lower end. This type of characteristic is particularly useful in suction controller applications, see Figure 2.

Reduced Trim

An optional reduced trim can be installed to reduce the flow area. The valve will maintain the line size connection, but keep the flow conditions inside the rangability of the valve. The reduced trim follows the equal percentage trim flow characteristics.

Kimray inherent flow characteristics conform to ANSI/ISA 75.11.01 -1985

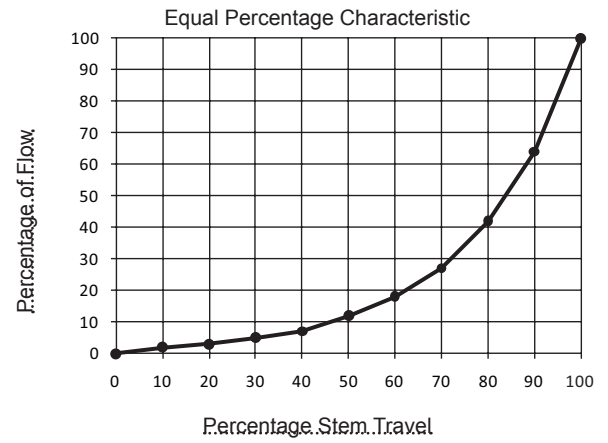

Figure 2

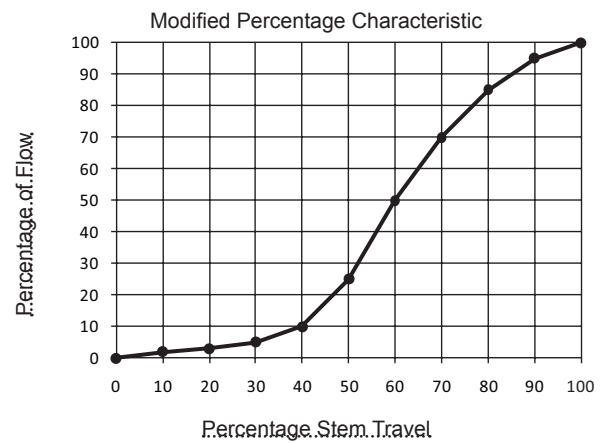

Figure 3

HIGH PRESSURE CONTROL VALVES



CAGE GUIDED INNER VALVES MODEL CVC

VALVE LINE SIZE	INNER VALVE SIZE	MATERIAL	ELASTOMERS	SEAT	RATIO PLUG	CATALOG CODE
2"	2"	D-2 STEEL	BUNA-N	6464	4720	EFB
		D-2 STEEL	AFLAS	6464	4720	EFBAF
		D-2 STEEL	VITON	6464	4720	EFBV
		S6	BUNA-N	6464SS6	4720SS6	EFBSS6
		S6	AFLAS	6464SS6	4720SS6	EFBS6AF
		S6	VITON	6464SS6	4720SS6	EFBS6V
		17-4PH	BUNA-N	6464PH	4720PH	EFBPH
		S6	HSN	6464SS6	4720SS6	EFBS6HSN
	2" QUICK OPENING	D-2 STEEL / S6	BUNA-N	6464	6672SS6	EFBQOV
		D-2 STEEL / ZIRCONIA	BUNA-N	6464	6641ZR	EFBQOZR
	1 1/2"	D-2 STEEL	BUNA-N	6464	4927	EFR
		S6	BUNA-N	6464SS6	4927SS6	EFRSS6
		S6	AFLAS	6464SS6	4927SS6	EFRS6AF
		S6	HSN	6464SS6	4927SS6	EFRS6HSN
		ZIRCONIA	BUNA-N	6464	4927	EFRZR
	3"	3"	D-2 STEEL	BUNA-N	6465	4985
S6			BUNA-N	6465SS6	4985SS6	EFCSS6
S6			VITON	6465SS6	4985SS6	EFC6V
17-4PH			BUNA-N	6465PH	4985PH	EFCPH
S6			AFLAS	6465SS6	4985SS6	EFC6AF
S6			HSN	6465SS6	4985SS6	EFC6HSN
ZIRCONIA			BUNA-N	6465	4985	EFCZR
3" QUICK OPENING		17-4PH / D2	BUNA-N	6465PH	7094	EFCQOPH
2"		D-2 STEEL	BUNA-N	6465	5123	EHZ
		D-2 STEEL	VITON	6465	5123	EHZV
		S6	BUNA-N	6465SS6	5123SS6	EHZS6
		S6	HSN	6465SS6	5123SS6	EHZS6HSN
		S6	VITON	6465SS6	5123SS6	EHZS6V
4"		4"	D-2 STEEL	BUNA-N	5583	5139
	D-2 STEEL		VITON	5583	5139	EFFV
	S6		BUNA-N	5583SS6	5139SS6	EFFSS6
	S6		VITON	5583SS6	5139SS6	EFFS6V
	S6		HSN	5583SS6	5139SS6	EFFS6HSN
	3"	ZIRCONIA	BUNA-N	5583	5139	EFFZR
		D-2 STEEL	BUNA-N	5583	5255	EVK
		D-2 STEEL	VITON	5583	5255	EVKV
		S6	BUNA-N	5583SS6	5255SS6	EVKS6
		S6	VITON	5583SS6	5255SS6	EVKS6V
6"	6"	D-2 STEEL	BUNA-N	5375SS6	5313	EFQ
		S6	BUNA-N	5375SS6	5313	EFQS6
		S6	AFLAS	5375SS6	5313SS6	EFQS6AF
	4"	S6 / D-2 STEEL	BUNA-N	5375SS6	6425	MGE
		S6 / D-2 STEEL	AFLAS	5375SS6	6425	MGEAF
		S6 / D-2 STEEL	HSN	5375SS6	6425	MGEHSN
		S6 / D-2 STEEL	VITON	5375SS6	6425	MGEV
		S6	BUNA-N	5375SS6	6425SS6	MGES6
S6	AFLAS	5375SS6	6425SS6	MGES6AF		
8" & 10"	8"	S6 / D-2 STEEL	BUNA-N	6570S6	6609	EIC
		S6	BUNA-N	6570S6	6609SS6	EICS6
		S6	HSN	6570S6	6609SS6	EICS6HSN
	6"	S6 / D-2 STEEL	BUNA-N	6570S6	6647	MGI
		S6	BUNA-N	6570S6	6647SS6	MGIS6
		S6	HSN	6570S6	6647SS6	HGIS6HSN

Standard Configuration Code †	Order Code ††	Line Size	Connection Type	Body Type	Inner Valve (Linear)	Max. W.P. psig †††	
CVS1S4TW02L2S	EAE	1"		Thru	1/8"	4000	
CVS1S4TW03L2S	EAF				3/16"		
CVS1S4TW04L2S	EAG				1/4"		
CVS1S4TW06L2S	EAH				3/8"		
CVS1S4TW08L2S	EAI				1/2"		
CVS1S4AW04L2S	EAA			Angle	1/4"		
CVS1S4AW06L2S	EAB				3/8"		
CVS1S4AW08L2S	EAC				1/2"		
CVS2S2TW04L2S	EQM				FNPT		Thru
CVS2S2TW06L2S	EDS	3/8"					
CVS2S2TW08L2S	ECN	1/2"					
CVS2S2TW12L2S	ECO	3/4"					
CVS2S2TW16L2S	ECP	1"					
CVS2S2AW04L2S	MBP	Angle	1/4"				
CVS2S2AW06L2S	EQK		3/8"				
CVS2S2AW08L2S	ECK		1/2"				
CVS2S2AW12L2S	ECL		3/4"				
CVS2S2AW16L2S	ECM		1"				
CVS2S4TW04L2S	EXT		2"	Thru		1/4"	4000
CVS2S4TW06L2S	EXZ	3/8"					
CVS2S4TW08L2S	ECR	1/2"					
CVS2S4TW12L2S	ECS	3/4"					
CVS2S4TW16L2S	ECT	1"					
CVS2S4AW08L2S	ETB	Angle				1/2"	
CVS2S4AW12L2S	ECQ			3/4"			
CVS2S4AW16L2S	ECU			1"			
CVS2S6TW04L6S	MGP			Thru	1/4"	6000	
CVS2S6TW06L6S	MGM				3/8"		
CVS2S6TW08L6S	MIF				1/2"		
CVS2S6TW12L6S	MGT	3/4"					
CVS2S6TW16L6S	MGZ	1"					
CVS2S6AW16L6S	MHB	Angle	1"				
CVS2ARTW04L2S	EHR	150RF	Thru	1/4"	285		
CVS2ARTW06L2S	EHS			3/8"			
CVS2ARTW08L2S	EHT			1/2"			
CVS2ARTW12L2S	EHU			3/4"			
CVS2ARTW16L2S	EHV			1"			

Standard Configuration Code †	Order Code ††	Line Size	Connection Type	Body Type	Inner Valve (Linear)	Max. W.P. psig †††			
CVS2ARAW04L2S	EPS	2"		150RF	1/4"	285			
CVS2ARAW06L2S	EPT				3/8"				
CVS2ARAW08L2S	EPW				1/2"				
CVS2ARAW12L2S	EPX				3/4"				
CVS2ARAW16L2S	EPY				1"				
CVS2BRTW04L2S	EPA				300RF		Thru	1/4"	740
CVS2BRTW06L2S	EPB							3/8"	
CVS2BRTW08L2S	EPC							1/2"	
CVS2BRTW12L2S	EPD							3/4"	
CVS2BRTW16L2S	EPE			1"					
CVS2BRAW04L2S	EZF			Angle		1/4"			
CVS2BRAW06L2S	EZG				3/8"				
CVS2BRAW08L2S	EZH				1/2"				
CVS2BRAW12L2S	EZI				3/4"				
CVS2BRAW16L2S	EDT				1"				
CVS2DRTW04L2S	EPJ				600RF	Thru	1/4"	1480	
CVS2DRTW06L2S	EDP			3/8"					
CVS2DRTW08L2S	EIE			1/2"					
CVS2DRTW12L2S	EGO	3/4"							
CVS2DRTW16L2S	EGP	1"							
CVS2DRAW04L2S	MFO	Angle	1/4"						
CVS2DRAW06L2S	MGK		3/8"						
CVS2DRAW08L2S	MCO		1/2"						
CVS2DRAW12L2S	MBT		3/4"						
CVS2DRAW16L2S	EVM		1"						
CVS2FRTW04L2S	EPK		1500RF	Thru		1/4"	3705		
CVS2FRTW06L2S	EPM	3/8"							
CVS2FRTW08L2S	EPN	1/2"							
CVS2FRTW12L2S	EGQ	3/4"							
CVS2FRTW16L2S	EGR	1"							
CVS2FRAW04L2S	MJF	Angle			1/4"				
CVS2FRAW16L2S	MIP		1"						
CVS2GJTW04L6S	MCV		2500RTJ	Thru	1/4"	6170			
CVS2GJTW06L6S	MFI				3/8"				
CVS2GJTW12L6S	MJG				3/4"				
CVS2GJTW16L6S	EVP				1"				
CVS2GJAW06L6S	MGR	Angle			3/8"				
CVS2GJAW16L6S	MBV	1"							
CVS2P5TW16L6S	MID	API5000	Thru	1"	5000				

NOTES:

Other options available. See authorized Kimray representative for details.

For standard & optional seals, metals, Cf Cv values, material specifications & dimensions see technical data on pages 01:I - 01:XI

† For Corrosive service remove last "S" & replace with "C"

† For Erosive option remove last "S" & replace with "E"

††† Max W.P. values based on -20°F to 100°F.

HIGH PRESSURE CONTROL VALVES



ITEM CODES MODEL CVC

Standard Configuration Code †	Order Code ††	Line Size	Connection Type	Inner Valve (EP)	Max. W.P. psig †††	
CVC2S1TWFEF2S	EFG	2"	FNPT	2"	1500	
CVC2S1TWREP2S	EQH		FNPT	1.5"		
CVC2S4TWFEF2S	EFH		FNPT	2"	4000	
CVC2S4TWREP2S	EQI		FNPT	1.5"		
CVC2ARTWFEP2S	EOQ		150RF	2"	285	
CVC2ARTWREP2S	EOR		150RF	1.5"		
CVC2BRTWFEP2S	EOS		300RF	2"	740	
CVC2BRTWREP2S	EOT		300RF	1.5"		
CVC2DRTWFEP2S	EFI		600RF	2"	1480	
CVC2DRTWREP2S	EQJ		600RF	1.5"		
CVC2FRTWFEP2S	EFK		1500RF	2"	3705	
CVC2FRTWREP2S	EOY		1500RF	1.5"		
CVC2DJTWFEF2S	EFJ		600RTJ	2"	1480	
CVC2DJTWREP2S	EOX		600RTJ	1.5"		
CVC2FJTWFEF2S	EFL		1500RTJ	2"	3705	
CVC2FJTWREP2S	EOZ		1500RTJ	1.5"		
CVC3ARTWFEP2S	EZO		3"	150RF	3"	285
CVC3ARTWREP2S	EZP			150RF	2"	
CVC3BRTWFEP2S	EZQ			300RF	3"	740
CVC3BRTWREP2S	EZR			300RF	2"	
CVC3DRTWFEP2S	EFU	600RF		3"	1480	
CVC3DRTWREP2S	EZU	600RF		2"		
CVC3DJTWFEF2S	EFV	600RTJ		3"		
CVC3DJTWREP2S	EZV	600RTJ		2"		
CVC4ARTWFEP2S	EQA	4"		150RF	4"	285
CVC4ARTWREP2S	EQB			150RF	3"	
CVC4BRTWFEP2S	EQC		300RF	4"	740	
CVC4BRTWREP2S	EQD		300RF	3"		
CVC4DRTWFEP2S	EGU		600RF	4"	1480	
CVC4DRTWREP2S	EQE		600RF	3"		
CVC4DJTWFEF2S	EQF		600RTJ	4"		
CVC4DJTWREP2S	EQG		600RTJ	3"		

Standard Configuration Code †	Order Code ††	Line Size	Connection Type	Inner Valve (EP)	Max. W.P. psig †††	
CVC6ARTWFEP2S	EIG	6"	150RF	6"	285	
CVC6ARTWREP2S	EIH		150RF	4"		
CVC6BRTWFEP2S	EIA		300RF	6"	740	
CVC6BRTWREP2S	EII		300RF	4"		
CVC6DRTWFEP2S	EIB		600RF	6"	1480	
CVC6DRTWREP2S	EIJ		600RF	4"		
CVC6DJTWFEF2S	EIK		600RTJ	6"		
CVC6DJTWREP2S	EIL		600RTJ	4"		
CVC8ARTWFEP2S	MFT		8"	150RF	8"	285
CVC8ARTWREP2S	MFU			150RF	6"	
CVC8BRTWFEP2S	EIN	300RF		8"	740	
CVC8BRTWREP2S	EIQ	300RF		6"		
CVC8DRTWFEP2S	EIM	600RF		8"	1480	
CVC8DRTWREP2S	EIR	600RF		6"		
CVC8DJTWFEF2S	EIS	600RTJ		8"		
CVC8DJTWREP2S	EIU	600RTJ		6"		
CVC0ARTWFEP2S	MGG	10"		150RF	8"	285
CVC0ARTWREP2S	MHC			150RF	6"	
CVC0BRTWFEP2S	EIX		300RF	8"	740	
CVC0BRTWREP2S	MFV		300RF	6"		
CVC0DRTWFEP2S	EIT		600RF	8"	1480	
CVC0DRTWREP2S	EIZ		600RF	6"		
CVC0DJTWFEF2S	ESK		600RTJ	8"		
CVC0DJTWREP2S	ESL		600RTJ	6"		

NOTES:

Other options available. See authorized Kimray representative for details.
 For standard & optional seals, metals, Cf Cv values, material specifications & dimensions see technical data on pages 01:I - 01:XI
 † For Corrosive service remove last "S" & replace with "C"
 † For Erosive option remove last "S" & replace with "E"
 ††† Max W.P. values based on -20°F to 100°F.

Standard Configuration Code †	Order Code ††	Line Size	Connection Type	Body Type	Inner Valve (EP)	Max. W.P. psig †††	
CVS SERIES							
CVS1S4TW04E8S	EGA	1"	FNPT	Thru	1/4"	4000	
CVS1S4TW08E8S	EGB		FNPT		1/2"		
CVS1S4AW04E8S	EEA		FNPT	Angle	1/4"		
CVS1S4AW08E8S	EEB		FNPT		1/2"		
CVS1S6TW08E8S	EIY		FNPT	Thru	1/2"	6000	
CVS1S6AW08E8S	MDT		FNPT		1/2"		
CVS1BRTW08E8S	MAY		2"	300RF	Thru	1/2"	740
CVS1DRTW08E8S	MHX			600RF		1/2"	1480
CVS1FJTW04E8S	MAO			1500RTJ		1/4"	3705
CVS2S2TW04E8S	EEJ			FNPT		Thru	1/4"
CVS2S2TW07E8S	EEL		FNPT	7/16"			
CVS2S2TW10E8S	EEN		FNPT	5/8"			
CVS2S2TW14E8S	EEO	FNPT	7/8"				
CVS2S2AW04E8S	MFL	FNPT	Angle	1/4"			
CVS2S2AW07E8S	EEK	FNPT		7/16"			
CVS2S2AW10E8S	EEM	FNPT	5/8"				
CVS2S2AW14E8S	EEO	FNPT	7/8"				
CVS2S4TW04E8S	MFR	2"	FNPT	Thru	1/4"	4000	
CVS2S4TW07E8S	MFA		FNPT		7/16"		
CVS2S4TW10E8S	EET		FNPT	5/8"			
CVS2S4TW14E8S	EEW		FNPT	7/8"			
CVS2S4AW10E8S	EES		FNPT	Angle	5/8"		
CVS2S4AW14E8S	EEV		FNPT		7/8"		

Standard Configuration Code †	Order Code ††	Line Size	Connection Type	Body Type	Inner Valve (EP)	Max. W.P. psig †††
CVC SERIES						
CVC2S1TWFEF8S	EFE	2"	FNPT	Thru	2"	1500
CVC2S1TWREP8S	MJN		FNPT		1.5"	1500
CVC2S4TWFEF8S	EGF		FNPT		2"	400
CVC2ARTWFEP8S	EDQ		150RF		285	
CVC2BRTWFEP8S	MDF		300RF		1.5"	740
CVC2DRTWFEP8S	EGE		600RF		2"	1480
CVC2DRTWREP8S	MDS		600RF		1.5"	3705
CVC2FRTWFEP8S	MBK		1500RF		2"	
CVC2FRTWREP8S	MHI		1500RF		1.5"	

NOTES:

Other options available. See authorized Kimray representative for details.

For standard & optional seals, metals, Cf Cv values, material specifications & dimensions see technical data on pages 01:I - 01:XI

† For Corrosive service remove last "S" & replace with "C"

† For Erosive option remove last "S" & replace with "E"

††† Max W.P. values based on -20°F to 100°F.

Standard Configuration Code †	Order Code ††	Line Size	Connection Type	Body Type	Inner Valve (EP)	Max. W.P. psig †††
CVS SERIES						
CVS2S6TW07E8S	EJP	2"	FNPT	Thru	7/16"	6000
CVS2S6TW14E8S	MIR		FNPT		7/8"	
CVS2ARTW04E8S	MDY		150RF	Angle	1/4"	285
CVS2ARTW07E8S	MDD		150RF		7/16"	
CVS2ARTW10E8S	MDC		150RF		5/8"	
CVS2ARTW14E8S	MCP		150RF		7/8"	
CVS2BRTW07E8S	MDB		300RF	Thru	7/16"	740
CVS2BRTW10E8S	MDA		300RF		5/8"	
CVS2BRTW14E8S	MCC		300RF	Angle	7/8"	1480
CVS2DRTW10E8S	EED		600RF		5/8"	
CVS2DRTW14E8S	EER		600RF	7/8"		
CVS2DRAW04E8S	MCK		600RF	Thru	1/4"	
CVS2DRAW07E8S	MCB	600RF	7/16"			
CVS2DRAW10E8S	MDG	600RF	Angle	5/8"		
CVS2DRAW14E8S	MCT	600RF		7/8"		
CVS2DJTW10E8S	EEU	600RTJ	Thru	5/8"	6170	
CVS2DJTW14E8S	EEX	600RTJ		7/8"		
CVS2DJAW04E8S	MCL	600RTJ	Angle	1/4"	3705	
CVS2FRTW14E8S	EZX	1500RF		7/8"		
CVS2FRAW14E8S	MGC	1500RF	Thru	7/8"		
CVS2FJTW10E8S	MDK	1500RTJ		5/8"		
CVS2FJTW14E8S	MBB	1500RTJ	Angle	7/8"		
CVS2GJTW07E8S	MAQ	2500RTJ		7/16"		
CVS2GJTW10E8S	MIC	2500RTJ	5/8"			

Standard Configuration Code †	Order Code ††	Line Size	Connection Type	Body Type	Inner Valve (EP)	Max. W.P. psig †††
CVC SERIES						
CVC2DJTWFEF8S	MDL	2"	600RTJ	Thru	2"	1480
CVC2FJTWFEF8S	MFP		1500RTJ		3705	
CVC3ARTWFEP8S	EIP	3"	150RF	Thru	3"	285
CVC3BRTWREP8S	MDQ		300RF		2"	740
CVC3BRTWFEP8S	MDE		300RF	3"	1480	
CVC3DRTWFEP8S	EGL		600RF			
CVC3DRTWREP8S	MCS		600RF	2"		
CVC3DJTWFEF8S	EGM		600RTJ	3"		

HIGH PRESSURE CONTROL VALVES



ITEM CODES

MODEL CVN, CVW, CVD & -65 TOPWORKS SERIES

Standard Configuration Code †	Order Code ††	Line Size	Connection Type	Body Type	Inner Valve (EP)	Max. W.P. psig †††
CVN SERIES						
CVN1S4AD04L2S	EBA	1"	FNPT	Angle	1/4"	4000
CVN1S4AD06L2S	EBB				3/8"	
CVN1S4AD08L2S	EBF				1/2"	
CVW SERIES FAIL CLOSE						
CVW1S33WFQK4S	ESE	1"	FNPT	3way	13/16"	3000
CVW2S33WFQK4S	ESW	2"				
CVW SERIES FAIL OPEN						
CVW1S33WFQKKS	ESD	1"	FNPT	3way	13/16"	3000
CVD SERIES FAIL CLOSE						
CVD2W33WFQKMS	ESZ	2"	Weld	3way	1 1/2"	3000
CVD SERIES FAIL OPEN						
CVD2S33WFQK2S	ESI	2"	FNPT	3way	1 1/2"	3000
CVD2W33WFQK4S	ESH		Weld			
CVN SERIES WITH -65						
CVN1S4AD04L7S	EBC	1"	FNPT	Angle	1/4"	4000
CVN1S4AD06L7S	EBD				3/8"	
CVN1S4AD08L7S	EBE				1/2"	
CVW SERIES WITH -65						
CVW1S33WFQK7S	ESF	1"	FNPT	3way	13/16"	3000

Standard Configuration Code †	Order Code ††	Line Size	Connection Type	Body Type	Inner Valve (EP)	Max. W.P. psig †††		
CVS SERIES WITH -65								
CVS1S4TW04L7S	EBI	1"	FNPT	Thru	1/4"	4000		
CVS1S4TW06L7S	MDM				3/8"			
CVS1S4TW08L7S	EBJ				1/2"			
CVS1S6TW02L7S	MGS				6000	1/8"		
CVS1S6TW04L7S	MAG						1/4"	
CVS1S6TW06L7S	MDI						3/8"	
CVS1S6TW08L7S	ESV			1/2"				
CVS1S4AW06L7S	EBH			150RF	Angle	3/8"	4000	
CVS1ARTW08L7S	EVI					1/2"	285	
CVS2S2TW12L7S	EVT			2"	FNPT	Thru	3/4"	2000
CVS2S2TW16L7S	EVS						1"	
CVS2S4TW08L7S	MGA						4000	
CVS2S4TW12L7S	ESQ	3/4"						
CVS2S4TW16L7S	EWE	1"						
CVS2S6TW04L7S	MHT	6000	1/4"					
CVS2S6TW06L7S	MGN					3/8"		
CVS2S6TW08L7S	EVN					1/2"		
CVS2S6TW12L7S	MBD	2000	3/4"					
CVS2S6TW16L7S	ETE					1"		
CVS2S2AW12L7S	MDX					Angle	6000	3/4"
CVS2S6AW04L7S	MFJ	1/4"						
CVS2S6AW06L7S	MBH	3/8"						
CVS2S6AW08L7S	ESX	1/2"						
CVS2S6AW12L7S	MBG	3/4"						
CVS2S6AW16L7S	MCG	1"						
CVS2ARTW12L7S	MJU	150RF	Thru	3/4"	285			
CVS2ARTW16L7S	MJT			1"				
CVS2DRTW08L7S	MHR	600RF	Thru	1/2"	1480			
CVS2DRTW12L7S	EVG			3/4"				
CVS2DRTW16L7S	EZY			1"				
CVS2DJTW16L7S	MIM	600RTJ	2500RTJ	3705	3705			
CVS2FJTW06L7S	MBI	1500RTJ				3/8"		
CVS2FJTW16L7S	MAP					1"		
CVS2GJTW04L7S	MBM	2500RTJ				1/4"		
CVS2GJTW12L7S	MGH					3/4"		
CVS2GJTW16L7S	EZW	API5000				Angle	1"	5000
CVS2GJAW16L7S	MBW							
CVS2P5TW16L7S	MCH							
CVS2P5AW16L7S	MHQ	Thru	Angle					

NOTES:

Other options available. See authorized Kimray representative for details.

For standard & optional seals, metals, Cf Cv values, material specifications & dimensions see technical data on pages 01:I - 01:XI

† For Corrosive service remove last "S" & replace with "C"

†† For Erosive option remove last "S" & replace with "E"

††† Max W.P. values based on -20°F to 100°F.

VOLUME-MILLIONS CU. FT. PER 24 HOURS - 65 SP. GR. AT 14.4 & 60°

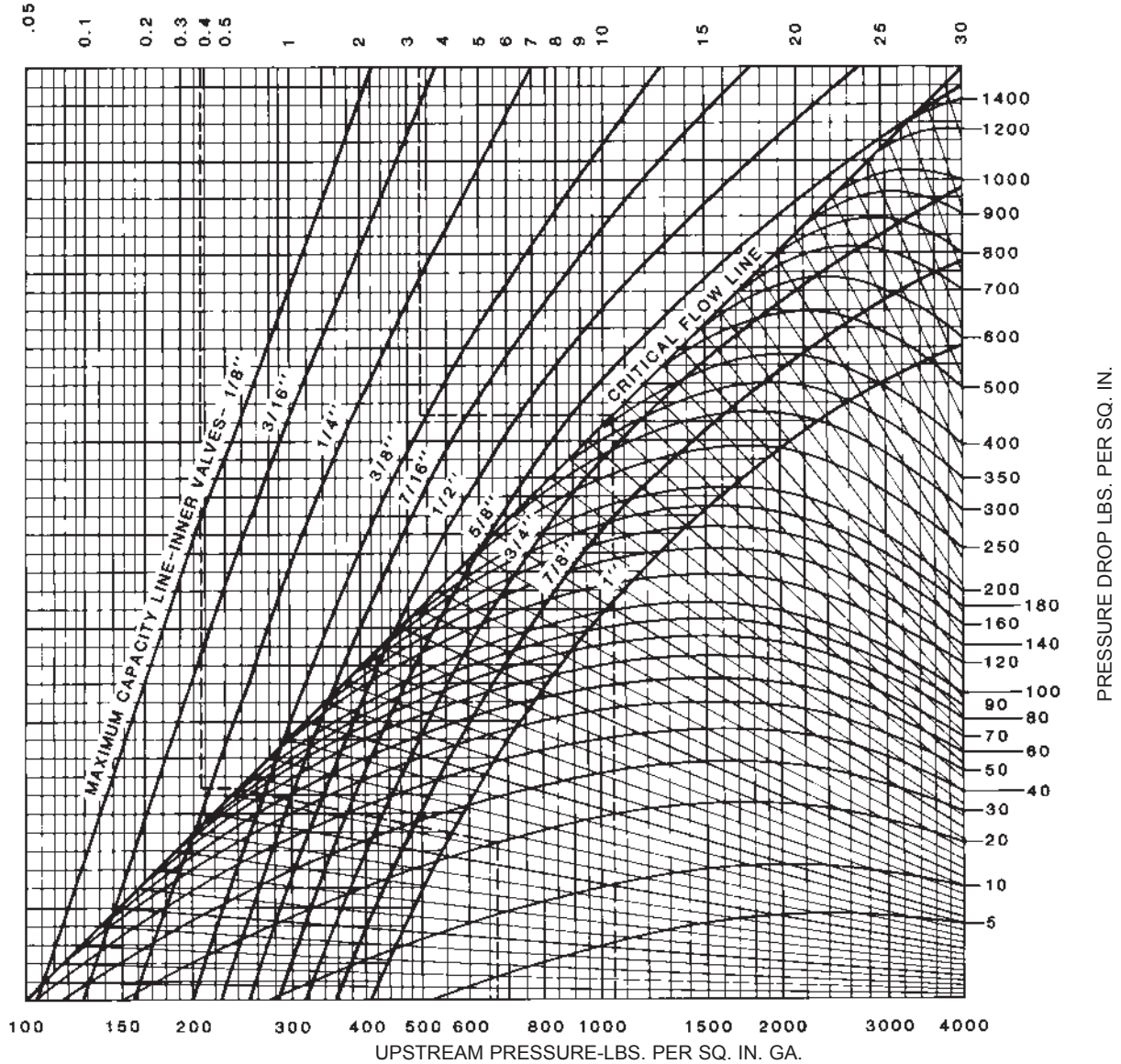

Gas capacities are based on pressures taken immediately upstream from the valve in a wide open position. Indicated volumes have been corrected for supercompressibility.

HOW TO USE CHART: PRESSURE DROP LESS THAN CRITICAL FLOW with: UPSTREAM PRESSURE 670 pounds gauge; PRESSURE DROP 20 pounds; VOLUME 380,000 Cu. Ft. per 24 hours.

Locate 670 at bottom of chart. Project a vertical line to intersect the 20 pound PRESSURE DROP line, and using sloping GUIDE LINES, project this point to the CRITICAL FLOWLINE. A horizontal line drawn through this point intersects all INNER VALVE lines at the maximum capacity is 0.43 millions of 430,000 Std. Cu. Ft. per 24 hours. A 3/8" is 0.78 and a 1/2" is 1.43. Select the inner valve size for the desired over-capacity.

CRITICAL FLOW with: UPSTREAM PRESSURE 1050 pounds gauge. PRESSURE DROP 600 pounds. VOLUME 3.3 millions per 24 hours.

Locate 1050 at bottom of chart. Project a vertical line to intersect the CRITICAL FLOW LINE. A horizontal line drawn through this point intersects all INNER VALVE LINES at the maximum capacity of each for the above conditions. A 3/8" inner valve maximum capacity is 3.4 millions and a 1/2" is 6.4 millions. Select the inner valve size for the desired over-capacity.

*For Gravity correction multiply above capacities by $\sqrt{.65/G}$; where G equals specific gravity of gas.

See Liquid Capacity Chart for maximum pressure drops on large inner valves.

Flow rates are for steady flow conditions over a 24-hour period. Corrections should be made to deal with intermittent flow conditions.

STEADY FLOW RATE - BARRELS WATER PER 24 HOURS

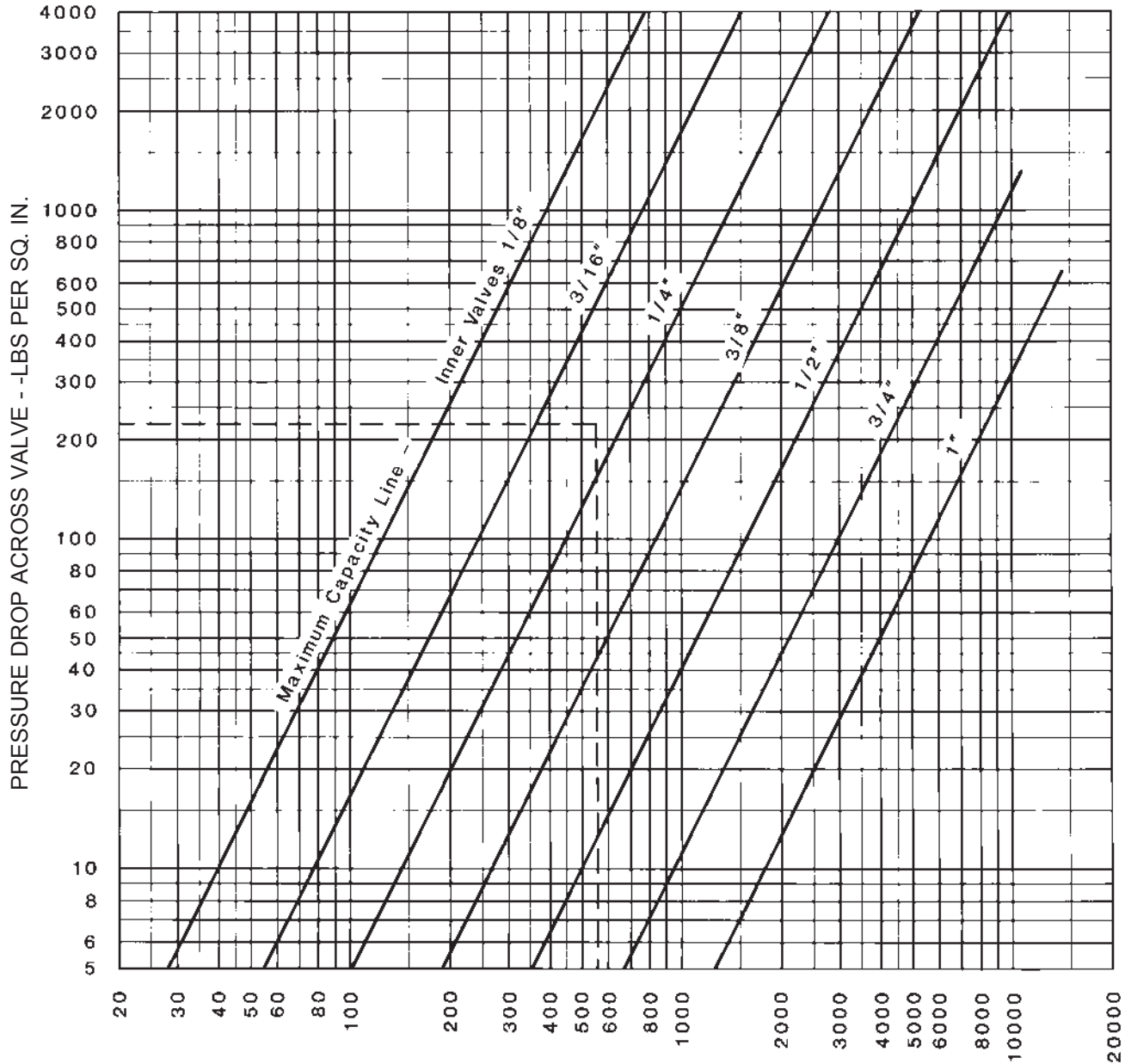

A good rule to follow when sizing liquid valves discharging from any kind of accumulator is to assume a volume at least twice than expected under steady flow conditions.

HOW TO USE CHART: Assume that it is desired to handle 275 barrels of water per day under steady flow conditions with a 225 psig pressure drop across the valve. Using the rule above we will use a volume of 550 barrels. The intersection of the 550 barrel line and the 225 psig pressure drop line lies between the 3/16" and 1/4" inner valve lines. Since the inner valve lines indicated maximum capacities, we must therefore select the 1/4" inner valve size to handle this volume.

*For gravity correction multiply above capacities by $1/\sqrt{G}$; where G equals specific gravity of flowing liquid.

MAXIMUM PRESSURE DROP for LARGE INNER VALVES

1" CONTROL VALVES			2" CONTROL VALVES		
I.V.	THROTTLE	RELIEF	I.V.	THROTTLE	RELIEF
1/2"	1200	2400	1"	650	1300
3/8"	1850	3700	3/4"	1350	2700

Above values are for valves furnished with standard springs for 20 psig diaphragm pressure.

NOTE: Flow rates are for steady flow conditions over a 24-hour period. Corrections should be made to deal with intermittent flow conditions.

Table 1 - Flow Coefficient(Cv)														
Line Size	Trim Size in. (mm)	Trim Type	Cf	Valve Opening Percentage										
				10	20	30	40	50	60	70	80	90	100	
Stem Guided														
1"	1/8 in (3.17 mm)	Linear (Nominal)	0.58	0.10	0.40	0.50	0.70	0.90	1.00	1.00	1.00	1.10	1.10	
	3/16 in (4.74 mm)		0.59	0.20	0.50	0.77	1.00	1.30	1.40	1.50	1.50	1.50	1.50	
	1/4 in (6.35 mm)		0.78	0.28	0.72	1.11	1.50	1.80	1.95	2.08	2.13	2.15	2.17	
	3/8 in (9.52 mm)		0.91	0.40	1.10	1.60	2.20	2.70	2.90	3.10	3.20	3.20	3.20	
	1/2 in (12.7 mm)		0.94	0.70	1.90	2.90	4.00	4.80	5.20	5.50	5.60	5.70	5.70	
2"	1/4 in (6.35 mm)		0.55	0.40	1.00	1.50	2.00	2.50	2.70	2.80	2.90	2.90	3.00	
	3/8 in (9.52 mm)		0.77	0.53	1.33	2.06	2.80	3.40	3.60	3.90	4.00	4.00	4.00	
	1/2 in (12.7 mm)		0.78	0.94	2.38	3.67	4.97	5.98	6.48	6.91	7.06	7.13	7.20	
	3/4 in (19.0 mm)		0.80	1.60	4.00	6.20	8.40	10.10	11.00	12.00	12.00	12.00	12.00	
	1 in (25.4 mm)		0.77	2.80	7.00	11.00	15.00	18.00	19.00	20.00	21.00	21.00	21.00	
1"	1/8 in (3.17 mm)		Quick Opening (Carbide)	0.73	0.39	0.40	0.40	0.40	0.40	0.40	0.40	0.40	0.40	0.40
	3/16 in (4.74 mm)			0.74	0.77	0.90	0.92	0.92	0.92	0.92	0.92	0.92	0.92	0.92
	1/4 in (6.35 mm)			0.68	0.88	1.51	1.67	1.71	1.73	1.73	1.74	1.74	1.74	1.74
	3/8 in (9.52 mm)	0.74		1.02	2.40	3.36	3.64	3.73	3.78	3.82	3.83	3.83	3.86	
	1/2 in (12.7 mm)	0.90		1.09	2.46	4.17	5.03	5.27	5.45	5.60	5.72	5.85	5.93	
2"	1/4 in (6.35 mm)	0.65		1.23	1.82	1.87	1.87	1.87	1.87	1.87	1.87	1.87	1.87	
	3/8 in (9.52 mm)	0.76		1.65	3.41	3.77	3.83	3.84	3.84	3.84	3.84	3.84	3.84	
	1/2 in (12.7 mm)	0.80		2.26	4.35	5.87	6.36	6.51	6.58	6.61	6.63	6.63	6.63	
	3/4 in (19.0 mm)	0.78		2.16	4.61	7.23	9.19	10.2	10.6	10.9	10.9	10.9	10.9	
	1 in (25.4 mm)	0.70		2.54	5.58	9.30	12.3	14.2	15.1	15.5	15.6	15.6	15.8	
1"	1/8 in (3.17 mm)	Equal Percentage		0.73	0.01	0.02	0.03	0.04	0.06	0.09	0.15	0.26	0.32	0.34
	1/4 in (6.35 mm)			0.66	0.05	0.10	0.14	0.19	0.29	0.58	0.93	1.27	1.63	1.99
	1/2 in (12.7 mm)			0.78	0.16	0.32	0.47	0.60	0.93	1.74	2.99	4.41	5.65	6.49
2"	1/4 in (6.35 mm)		0.65	0.10	0.14	0.19	0.23	0.27	0.55	0.82	1.12	1.62	1.72	
	7/16 in (11.1 mm)		0.60	0.10	0.30	0.50	0.70	1.00	1.50	2.60	3.80	4.80	5.40	
	5/8 in (15.8 mm)		0.58	0.30	0.50	0.90	1.10	1.40	2.30	3.90	6.40	8.70	10.80	
	7/8 in (22.2 mm)		0.66	0.40	0.90	1.57	2.10	3.00	4.20	6.30	9.60	13.00	17.00	
Cage Guided														
2"	1 1/2 in (38mm)		Equal Percentage	0.75	0.60	1.30	2.20	3.40	5.00	8.60	14.0	21.0	26.0	28.6
	2 in (51 mm)	0.76		2.00	4.00	6.00	8.00	11.0	20.0	33.0	45.0	51.0	57.0	
3"	2 in (51 mm)	0.75		2.90	4.90	7.40	9.50	12.0	17.4	28.9	40.8	48.1	52.6	
	3 in (76 mm)	0.76		4.00	6.00	10.0	13.0	16.0	26.0	54.0	83.0	97.0	107	
4"	3 in (76 mm)	0.75		4.00	6.00	9.00	12.0	16.0	25.0	52.0	81.0	95.0	115	
	4 in (102 mm)	0.75		9.00	13.0	18.0	26.0	36.0	64.0	104	148	197	222	
6"	4 in (102 mm)	0.75		9.00	13.0	18.0	26.0	36.0	64.0	104	148	197	222	
	6 in (152 mm)	0.75		7.00	20.0	45.0	78.0	108	140	222	318	399	431	
8"	6 in (152 mm)	0.75		47.0	60.0	90.0	106	119	139	173	243	294	453	
	8 in (203 mm)	0.75		51.0	53.0	235	362	485	584	665	699	745	810	
10"	6 in (152 mm)	0.75		26.0	37.0	46.0	53.0	56.0	58.0	104	146	655	655	
	8.5 in (216 mm)	0.75		28.0	72.0	420	509	632	678	769	814	832	1091	
8"	8 in (203 mm)	Modified E.P.		0.75	51.0	55.0	64.0	134	162	330	452	527	571	630
10"	8.5 in (216 mm)		0.75	21.0	22.0	27.0	103	209	429	596	663	695	884	
2"	2 in (51 mm)	Quick Open	0.76	0.80	1.50	6.10	13.0	20.2	27.6	35.6	42.4	48.8	53.0	
3"	3 in (76 mm)		0.76	5.10	21.3	42.4	63.8	83.0	97.7	105	111	113	115	
4"	4 in (102 mm)		0.75	8.20	43.8	80.0	119	170	211	237	247	252	253	

HIGH PRESSURE CONTROL VALVES



DIMENSIONS 1" MODEL CVS

1" HPCV

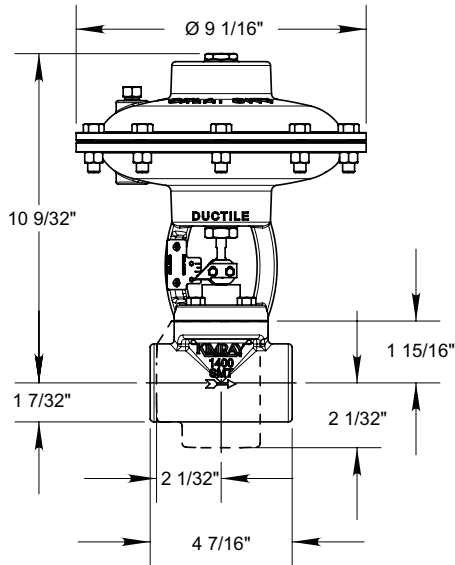

1" HPCV -65 TOPWORKS

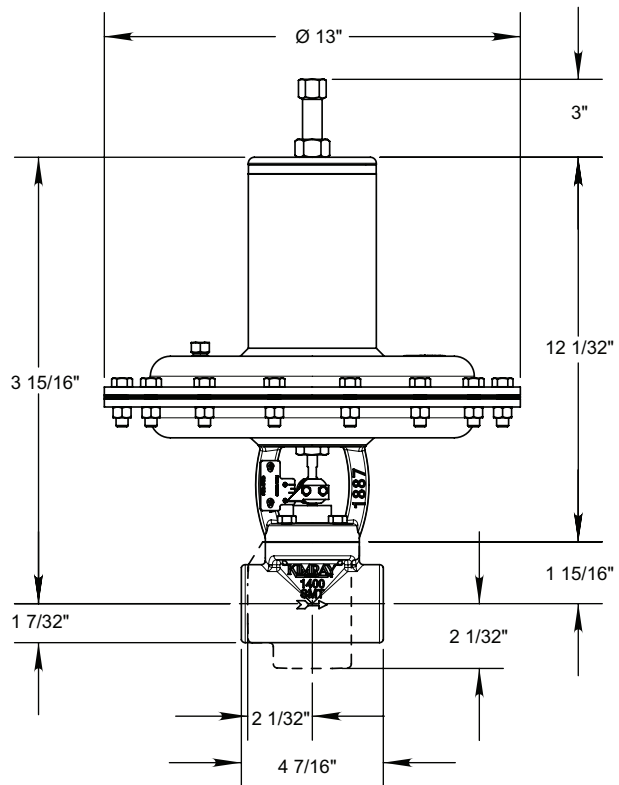

1" SMS

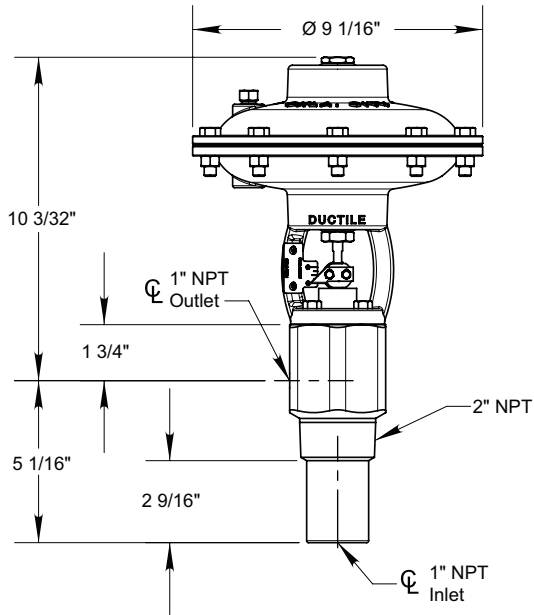

1" SMS -65 TOPWORKS

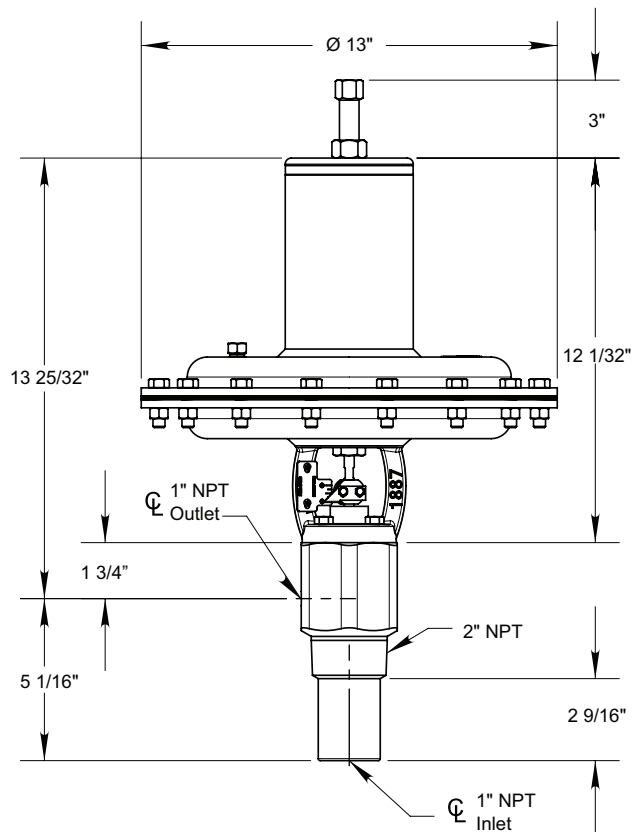

1" SMVA/T

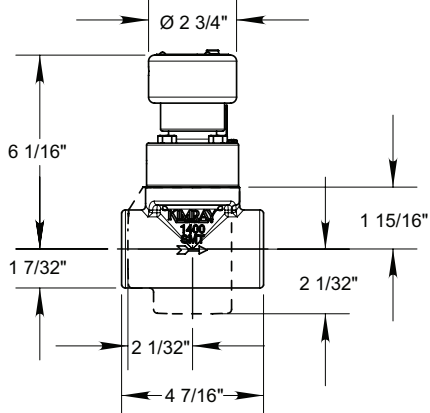

All Pictures shown are for illustration purpose only. Actual product may vary due to product enhancement.

2" HPCV PB

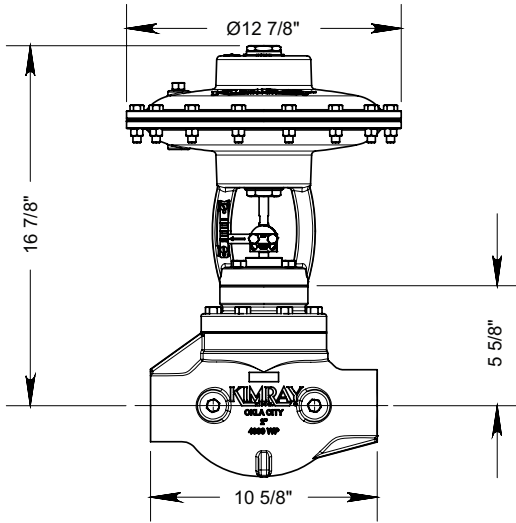

2" SMD

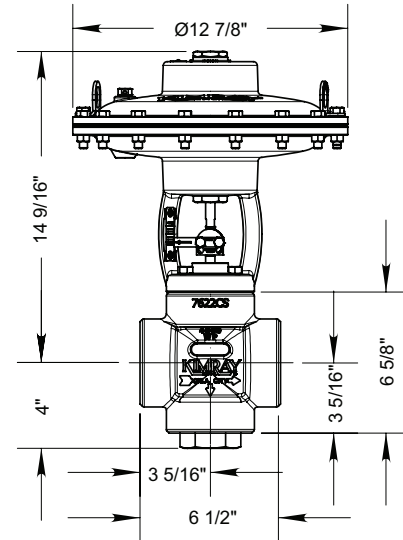

2" HPCV

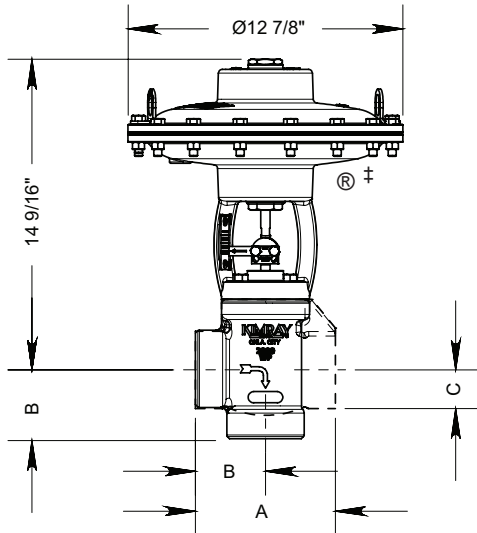

2" -65 TOPWORKS

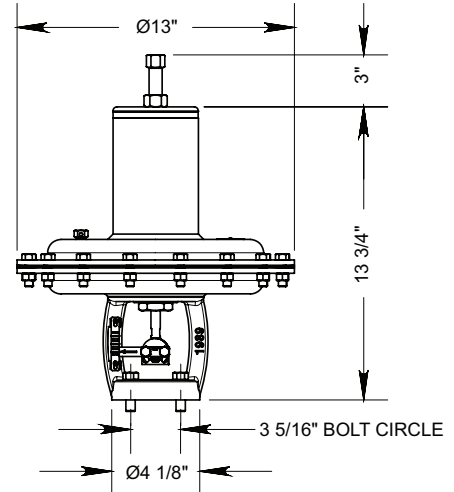

2" SMVA/T TOPWORKS

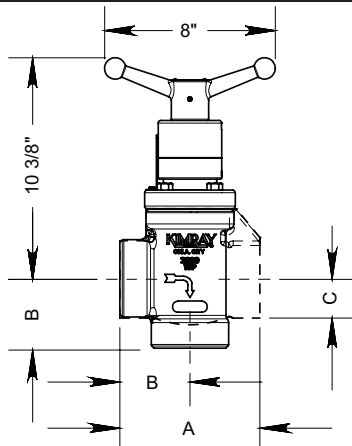

2" MVP TOPWORKS

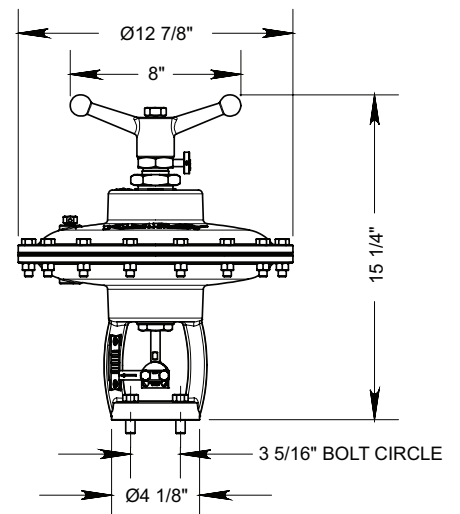

MODEL NO.	A	B	C
2200	6 9/16"	3 9/32"	1 13/16"
2400	6 9/16"	3 9/32"	2 1/16"

All dimensions are in inches
Flanged body dimensions available on request.

All Pictures shown are for illustration purpose only. Actual product may vary due to product enhancement.
‡ Configuration of High Pressure Control Valve is a trademark of Kimray, Inc.
www.kimray.com

HIGH PRESSURE CONTROL VALVES



DIMENSIONS

FLANGED BODY MODEL CVS & CVC

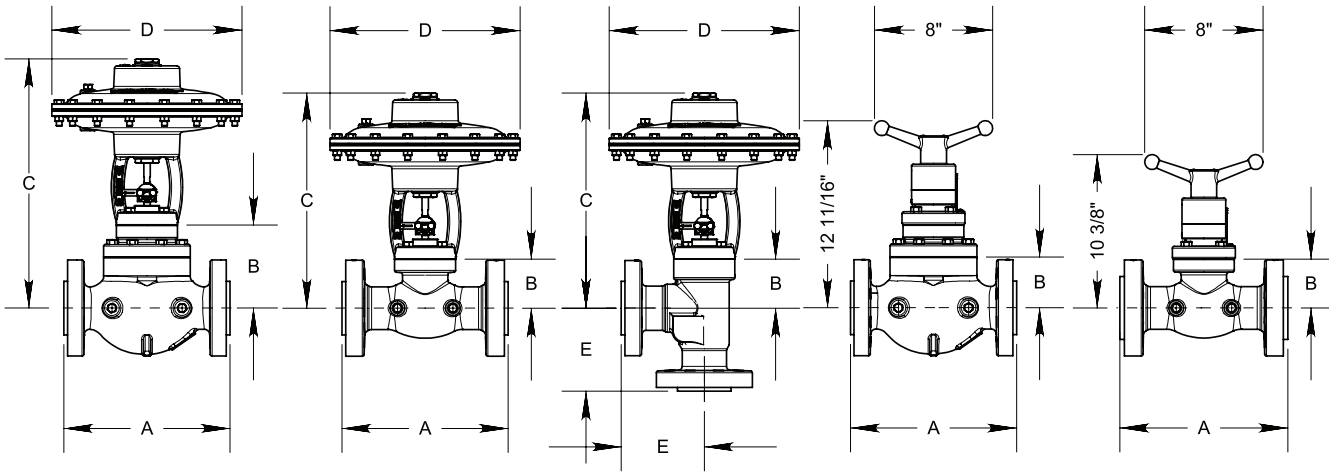

	SIZE	BODY STYLE	A	B	C	D	E
STEM GUIDED	1"	150RF	7 1/4"	1 15/16"	10 1/2"	9 1/8"	
		150RTJ	7 5/8"	1 15/16"	10 1/2"	9 1/8"	
		300RF	7 3/4"	1 15/16"	10 1/2"	9 1/8"	
		300RTJ	8 1/8"	1 15/16"	10 1/2"	9 1/8"	
		600RF	8 1/4"	1 15/16"	10 1/2"	9 1/8"	
		600RTJ	8 1/4"	1 15/16"	10 1/2"	9 1/8"	
		1500RF	10 3/4"	1 15/16"	10 1/2"	9 1/8"	
	1500RTJ	10 3/4"	1 15/16"	10 1/2"	9 1/8"		
	2"	150RF	10"	3 3/16"	14 1/2"	12 7/8"	5"
		150RTJ	10 3/8"	3 3/16"	14 1/2"	12 7/8"	5"
		300RF	10 1/2"	3 3/16"	14 1/2"	12 7/8"	5 1/2"
		300RTJ	11"	3 3/16"	14 1/2"	12 7/8"	5 1/4"
		600RF	11 1/4"	3 3/16"	14 1/2"	12 7/8"	5 5/8"
		600RTJ	11 3/8"	3 3/16"	14 1/2"	12 7/8"	5 5/8"
		1500RF	13 3/8"	3 3/16"	14 1/2"	12 7/8"	7 13/32"
	1500RTJ	13 1/2"	3 3/16"	14 1/2"	12 7/8"	7 13/32"	
	2500RTJ	16 3/8"	3 3/16"	14 1/2"	12 7/8"		
2-1/16 API 5000	14 3/4"	4 1/4"	14 1/2"	12 7/8"	7 3/8"		
CAGE GUIDED	2"	150RF	10"	5 5/8"	17"	12 7/8"	
		300RF	10 1/2"	5 5/8"	17"	12 7/8"	
		600RF	11 1/4"	5 5/8"	17"	12 7/8"	
		1500RF	13 3/8"	5 5/8"	17"	12 7/8"	
		1500RTJ	13 1/2"	5 5/8"	17"	12 7/8"	
	3"	150RF	11 3/4"	7 1/4"	27"	15 3/4"	
		300RF	12 1/2"	7 1/4"	27"	15 3/4"	
		600RF	13 1/4"	7 1/4"	27"	15 3/4"	
		600RTJ	13 3/8"	7 1/4"	27"	15 3/4"	
	4"	150RF	13 7/8"	11"	30"	15 3/4"	
		300RF	14 1/2"	11"	30"	15 3/4"	
		600RF	15 1/2"	11"	30"	15 3/4"	
	6"	150RF	17 3/4"	11 3/16"	34 1/2"	20 7/16"	
		300RF	18 5/8"	11 3/16"	34 1/2"	20 7/16"	
		600RF	20 1/16"	11 3/16"	34 1/2"	20 7/16"	
	8"	150RF	21 3/8"	11 5/16"	34 1/2"	20 1/2"	
		300RF	22 3/8"	11 5/16"	34 1/2"	20 1/2"	
600RF		24"	11 5/16"	34 1/2"	20 1/2"		
10"	150RF	26 1/2"	11 5/16"	34 1/2"	20 1/2"		
	300RF	27 7/8"	11 5/16"	34 1/2"	20 1/2"		
	600RF	29 9/16"	11 5/16"	34 1/2"	20 1/2"		

All Pictures shown are for illustration purpose only. Actual product may vary due to product enhancement.

Table 2 - Seal Options		
Part	Standard Material	Optional Material
Diaphragm	Nitrile	FKM
Packing Rings	Nitrile	FKM, Aflas, HSN, Graphite
Packing Sleeve	Teflon	
O-rings	Nitrile	FKM, Aflas, HSN
Seal Ring	Polyurethane	Aflas

Table 3 - Seal Specifications							
		NITRILE	HIGHLY SATURATED NITRILE	FKM	AFLAS®	TEFLON	GRAPHITE PACKING
	Kimray Suffix	-	HSN	V	AF	T	G
Resistance	Abrasion	G	G-E	G	G	E	PF
	Acid	F	G-E	G-E	E	E	G
	Chemical	F	F	E	E	E	E
	Cold	G	G	P	P	E	E
	Flame	P	P	E	E	P	E
	Heat	G	E	E	E	E	E
	Oil	G-E	E	E	E	E	E
	Ozone	P	G	G-E	E	E	F
	Set	G	G	G-E	P	P	G
	Tear	F	F	F	P	E	P
	Water/Steam	F	E	P	G	E	E
	Weather	F	G	E	E	E	E
	CO2	F-G	G	G	G	E	E
	H2S	P	F	P	E	E	E
Methanol	F	E	P	P	E	E	
Properties	Dynamic	G	G	G	G	P	E
	Electrical	F	F	F	G-E	E	Conductive
	Impermeability	G	G	G	G	E	G
	Tensile Strength	G	G-E	G	F	E	P
Temp. Range		-20° to +250°F	-20° to +300°F	-15° to +400°F	+15° to +450°F	-450° to +500°F	-328° to +850°F
		-29° to +121°C	-29° to +149°C	-26° to +204°C	-9° to +232°C	-268° to +260°C	-200° to +455°C
RATINGS: P-POOR, F-FAIR, G-GOOD, E-EXCELLENT							

Table 5 - Material Options Stem Guided			
Part Description	Standard Material	Erosive Material	Corrosive Material
Body	WCB (ASTM A216)		WCB (ASTM A216) ‡
Actuator	Ductile (ASTM A395)		
Stuffing Box	Carbon Steel (ASTM A105)		316SS (ASTM A479)
Cage	Alloy Steel (ASTM A108)		316SS (ASTM A479)
Stem	303SS (ASTM A582)		316SS (ASTM A479)
Plug*	Chrome Alloy	Tungsten Carbide	316SS (ASTM A479)
Seat	D-2 (ASTM A681)	Zirconia	316SS (ASTM A479)
Cover Bonnet (Metering Valve)	WCB (ASTM A216)		

*Material can vary by trim size. See Page 01:200.2

‡ Coated Parts available with "K" service type

Table 6 - Material Options Cage Guided			
Part Description	Standard Material	Erosive Material	Corrosive Material
Body	WCB (ASTM A216)		WCB (ASTM A216) ‡
Actuator	Ductile (ASTM A395)		
Stuffing Box	2" - 4"	Carbon Steel (ASTM A105)	316SS (ASTM A479)
	6" - 10"	316SS (ASTM A479)	
Cover Bonnet (Upper Housing)	WCB (ASTM A216)		WCB (ASTM A216) ‡
Cage	2 & 3 inch 316SS (ASTM A479)	4-10 inch 316SS (ASTM A351 CF8M)	
Stem	316SS (ASTM A479)	303SS (ASTM A582)	316SS (ASTM A479)
Piston	316SS (ASTM A479)	D-2 (ASTM A597)	316SS (ASTM A479)
Seat Disc	D2 (ASTM A681)	Zirconia	316SS (ASTM A479)
Ratio Plug	D-2 (ASTM A597)		316SS (ASTM A351 CF8M)
Seat	D-2 (ASTM A681)		316SS (ASTM A479)
Bonnet (Metering Valve)	WCB (ASTM A216)		

‡ Coated Parts available with "K" service type

Table 6 - 1" Stem Guided HPCV

Valve Description	ΔP	0 psig (0 bar)		100 psig (6.8 bar)		500 psig (34.4 bar)		1000 psig (68.9 bar)		1500 psig (103.4 bar)	
	Spring	Crack	Full	Crack	Full	Crack	Full	Crack	Full	Crack	Full
1400 SMT PO 1/8" IV	621 (10 lbs)	3 psig (0.21 bar)	9.5 psig (0.66 bar)	3 psig (0.21 bar)	9 psig (0.62 bar)	3 psig (0.21 bar)	8.5 psig (0.59 bar)	2 psig (0.13 bar)	7 psig (0.48 bar)	2 psig (0.13 bar)	6 psig (0.41 bar)
	463 (20 lbs)	6.5 psig (0.44 bar)	20.5 psig (1.41 bar)	6 psig (0.41 bar)	20 psig (1.37 bar)	6 psig (0.41 bar)	19.5 psig (1.34 bar)	5.5 psig (0.37 bar)	18 psig (1.24 bar)	5.5 psig (0.37 bar)	17.5 psig (1.20 bar)
	464 (30 lbs)	9.5 psig (0.65 bar)	34 psig (2.34 bar)	9.5 psig (0.65 bar)	34 psig (2.34 bar)	9 psig (0.62 bar)	33 psig (2.27 bar)	9 psig (0.62 bar)	32 psig (2.20 bar)	8.5 psig (0.58 bar)	31 psig (2.13 bar)
1400 SMT PO 1/8" IV EP	621 (10 lbs)	3.5 psig (0.23 bar)	10 psig (0.68 bar)	3.5 psig (0.23 bar)	10 psig (0.68 bar)	3 psig (0.21 bar)	8.5 psig (0.58 bar)	2.5 psig (0.17 bar)	7.5 psig (0.51 bar)	2 psig (0.13 bar)	6 psig (0.41 bar)
	463 (20 lbs)	7 psig (0.48 bar)	21.5 psig (1.48 bar)	7 psig (0.48 bar)	21 psig (0.44 bar)	6.5 psig (0.44 bar)	19.5 psig (1.34 bar)	6 psig (0.41 bar)	18.5 psig (1.27 bar)	6 psig (0.41 bar)	17.5 psig (1.20 bar)
	464 (30 lbs)	12.5 psig (0.86 bar)	38 psig (2.61 bar)	12.5 psig (0.86 bar)	38 psig (2.61 bar)	11 psig (0.75 bar)	35.5 psig (2.44 bar)	10.5 psig (0.72 bar)	34.5 psig (2.37 bar)	10 psig (0.68 bar)	33 psig (2.27 bar)
1400 SMT PO 3/16" IV	621 (10 lbs)	3.5 psig (0.23 bar)	10.5 psig (0.72 bar)	3.5 psig (0.23 bar)	10 psig (0.68 bar)	3.5 psig (0.23 bar)	9 psig (0.62 bar)	3.5 psig (0.23 bar)	7.5 psig (0.51 bar)	3 psig (0.21 bar)	6.5 psig (0.44 bar)
	463 (20 lbs)	6.5 psig (0.44 bar)	21.5 psig (1.48 bar)	6.5 psig (0.44 bar)	21 psig (1.44 bar)	7.5 psig (0.51 bar)	21 psig (1.44 bar)	7 psig (0.48 bar)	19.5 psig (1.34 bar)	7 psig (0.48 bar)	18.5 psig (1.27 bar)
	464 (30 lbs)	11 psig (0.75 bar)	36 psig (2.48 bar)	10.5 psig (0.72 bar)	36 psig (2.48 bar)	11 psig (0.75 bar)	35 psig (2.41 bar)	11 psig (0.75 bar)	34 psig (2.34 bar)	10.5 psig (0.72 bar)	32.5 psig (2.23 bar)
1400 SMT PO 1/4" IV	621 (10 lbs)	3 psig (0.21 bar)	9.5 psig (0.65 bar)	3 psig (0.21 bar)	9 psig (0.62 bar)	3 psig (0.21 bar)	8.5 psig (0.58 bar)	2.5 psig (0.17 bar)	7.5 psig (0.51 bar)	2.5 psig (0.17 bar)	6.5 psig (0.44 bar)
	463 (20 lbs)	6 psig (0.41 bar)	20.5 psig (1.41 bar)	6 psig (0.41 bar)	20 psig (1.37 bar)	6 psig (0.41 bar)	19.5 psig (1.34 bar)	5.5 psig (0.37 bar)	18 psig (1.24 bar)	5.5 psig (0.37 bar)	17 psig (1.20 bar)
	464 (30 lbs)	10 psig (0.68 bar)	35 psig (2.41 bar)	10 psig (0.68 bar)	35 psig (2.42 bar)	10 psig (0.68 bar)	34 psig (2.34 bar)	9.5 psig (0.65 bar)	33 psig (2.27 bar)	9 psig (0.62 bar)	32 psig (2.20 bar)
1400 SMT PO 1/4" IV EP	621 (10 lbs)	3 psig (0.20 bar)	10 psig (0.68 bar)	3 psig (0.20 bar)	9.5 psig (0.65 bar)	2.5 psig (0.17 bar)	8 psig (0.55 bar)	2.5 psig (0.17 bar)	7 psig (0.48 bar)	2 psig (0.13 bar)	6 psig (0.41 bar)
	463 (20 lbs)	6.5 psig (0.44 bar)	21.5 psig (1.48 bar)	6.5 psig (0.44 bar)	20 psig (1.37 bar)	6 psig (0.41 bar)	20 psig (1.37 bar)	6 psig (0.41 bar)	18.5 psig (1.27 bar)	6 psig (0.41 bar)	17.5 psig (1.20 bar)
	464 (30 lbs)	12 psig (0.83 bar)	40 psig (2.75 bar)	11.5 psig (0.79 bar)	39 psig (2.68 bar)	9.5 psig (0.66 bar)	35 psig (2.42 bar)	9 psig (0.62 bar)	33 psig (2.27 bar)	9 psig (0.62 bar)	32 psig (2.20 bar)
1400 SMT PO 3/8" IV SNAP	621 (10 lbs)	4.5 psig (0.31 bar)	10.5 psig (0.72 bar)	4.5 psig (0.31 bar)	10.5 psig (0.72 bar)	5.5 psig (0.38 bar)	9.5 psig (0.66 bar)	6.5 psig (0.44 bar)	8 psig (0.55 bar)	7.5 psig (0.51 bar)	7 psig (0.48 bar)
	463 (20 lbs)	7 psig (0.48 bar)	21.5 psig (1.48 bar)	7 psig (0.48 bar)	21 psig (1.44 bar)	9.5 psig (0.65 bar)	21 psig (0.44 bar)	10.5 psig (0.72 bar)	20 psig (1.37 bar)	11 psig (0.75 bar)	19 psig (1.31 bar)
	464 (30 lbs)	11 psig (0.75 bar)	35 psig (2.41 bar)	11 psig (0.75 bar)	35 psig (2.41 bar)	13 psig (0.89 bar)	35 psig (2.42 bar)	14 psig (0.97 bar)	33 psig (2.27 bar)	15.5 psig (1.06 bar)	32 psig (2.20 bar)
1400 SMT PO 3/8" IV	621 (10 lbs)	3 psig (0.20 bar)	9 psig (0.62 bar)	3 psig (0.20 bar)	9 psig (0.62 bar)	5 psig (0.34 bar)	9 psig (0.62 bar)	6.5 psig (0.44 bar)	7.5 psig (0.51 bar)	7.5 psig (0.51 bar)	6.5 psig (0.44 bar)
	463 (20 lbs)	6 psig (0.41 bar)	20.5 psig (1.41 bar)	6 psig (0.41 bar)	20 psig (1.37 bar)	8.5 psig (0.58 bar)	21 psig (0.44 bar)	9.5 psig (0.65 bar)	20 psig (1.37 bar)	10.5 psig (0.72 bar)	18.5 psig (1.27 bar)
	464 (30 lbs)	9.5 psig (0.66 bar)	34 psig (2.34 bar)	9.5 psig (0.66 bar)	34 psig (2.34 bar)	11.5 psig (0.79 bar)	33 psig (2.27 bar)	12.5 psig (0.85 bar)	32 psig (2.20 bar)	13.5 psig (0.93 bar)	31 psig (2.14 bar)
1400 SMT PO 1/2" IV	621 (10 lbs)	3 psig (0.20 bar)	10.5 psig (0.72 bar)	3 psig (0.20 bar)	10 psig (0.68 bar)	5.5 psig (0.38 bar)	8.5 psig (0.58 bar)	7 psig (0.48 bar)	7.5 psig (0.51 bar)	9 psig (0.62 bar)	6.5 psig (0.44 bar)
	463 (20 lbs)	6.5 psig (0.44 bar)	21 psig (0.44 bar)	6 psig (0.41 bar)	20.5 psig (1.41 bar)	8.5 psig (0.58 bar)	19.5 psig (1.34 bar)	10 psig (0.68 bar)	18.5 psig (1.27 bar)	12 psig (0.83 bar)	17.5 psig (1.20 bar)
	464 (30 lbs)	11.5 psig (0.79 bar)	37 psig (2.54 bar)	11 psig (0.75 bar)	36 psig (2.48 bar)	13.5 psig (0.93 bar)	35 psig (2.41 bar)	15 psig (1.03 bar)	34 psig (2.34 bar)	17 psig (1.20 bar)	33 psig (2.27 bar)
1400 SMT PO 1/2" IV EP	621 (10 lbs)	3.5 psig (0.24 bar)	10 psig (0.68 bar)	3.5 psig (0.24 bar)	9.5 psig (0.66 bar)	7 psig (0.48 bar)	10 psig (0.68 bar)	7.5 psig (0.52 bar)	7.5 psig (0.51 bar)	9.5 psig (0.65 bar)	6 psig (0.41 bar)
	463 (20 lbs)	7 psig (0.48 bar)	21.5 psig (1.48 bar)	7.5 psig (0.51 bar)	21.5 psig (1.48 bar)	10.5 psig (0.72 bar)	21 psig (0.44 bar)	12.5 psig (0.86 bar)	20.5 psig (1.41 bar)	14 psig (0.97 bar)	19 psig (1.31 bar)
	464 (30 lbs)	11 psig (0.75 bar)	37 psig (2.54 bar)	11 psig (0.75 bar)	37 psig (2.54 bar)	14 psig (0.97 bar)	35 psig (2.41 bar)	16 psig (1.10 bar)	34 psig (2.34 bar)	18 psig (1.24 bar)	33 psig (2.27 bar)

Table 7 - 2" Stem Guided HPCV

Valve Description	ΔP	0 psig (0 bar)		100 psig (6.8 bar)		500 psig (34.4 bar)		1000 psig (68.9 bar)		1500 psig (103.4 bar)	
	Spring	Crack	Full	Crack	Full	Crack	Full	Crack	Full	Crack	Full
2400 SMT PO 1/4" EP IV	1245 (15 lbs)	3.5 psig (0.24 bar)	15.5 psig (1.06 bar)	3 psig (0.20 bar)	15 psig (1.03 bar)	2.5 psig (0.17 bar)	15 psig (1.03 bar)	2 psig (0.13 bar)	14.5 psig (1.00 bar)	1.5 psig (0.10 bar)	13 psig (0.89 bar)
	538 (20 lbs)	3.5 psig (0.24 bar)	18 psig (1.24 bar)	3.5 psig (0.24 bar)	17.5 psig (1.20 bar)	3.5 psig (0.24 bar)	17.5 psig (1.20 bar)	2.5 psig (0.17 bar)	16.5 psig (1.13 bar)	1.5 psig (0.10 bar)	15 psig (1.03 bar)
	508 (30 lbs)	7.5 psig (0.52 bar)	32 psig (2.20 bar)	7 psig (0.48 bar)	32 psig (2.20 bar)	6.5 psig (0.44 bar)	31 psig (2.14 bar)	6 psig (0.41 bar)	30 psig (2.07 bar)	5.5 psig (0.38 br)	29 psig (2.00 bar)
2400 SMT PO 1/4" IV	1245 (15 lbs)	3.5 psig (0.24 bar)	16 psig (1.10 bar)	3.5 psig (0.24 bar)	16 psig (1.10 bar)	3 psig (0.20 bar)	14.5 psig (1.00 bar)	3 psig (0.20 bar)	13 psig (0.89 bar)	3 psig (0.20 bar)	12.5 psig (0.85 bar)
	538 (20 lbs)	4 psig (0.27 bar)	18.5 psig (1.27 bar)	3.5 psig (0.24 bar)	18.5 psig (1.27 bar)	3.5 psig (0.24 bar)	18 psig (1.24 bar)	3 psig (0.20 bar)	17.5 psig (1.20 bar)	3 psig (0.20 bar)	16.5 psig (1.13 bar)
	508 (30 lbs)	6.5 psig (0.44 bar)	32 psig (2.20 bar)	6.5 psig (0.44 bar)	33 psig (2.27 bar)	7 psig (0.48 bar)	31 psig (2.14 bar)	6.5 psig (0.44 bar)	30 psig (2.07 bar)	6.5 psig (0.44 bar)	29 psig (2.00 bar)
2400 SMT PO 1/4" IV SNAP	1245 (15 lbs)	3.5 psig (0.23 bar)	15.5 psig (1.06 bar)	4 psig (0.27 bar)	15.5 psig (1.06 bar)	3 psig (0.20 bar)	15 psig (1.03 bar)	2.5 psig (0.17 bar)	14.5 psig (1.00 bar)	2 psig (0.13 bar)	14 psig (0.97 bar)
	538 (20 lbs)	4 psig (0.27 bar)	18 psig (1.24 bar)	4 psig (0.27 bar)	18 psig (1.24 bar)	3 psig (0.20 bar)	17 psig (1.22 bar)	2.5 psig (0.17 bar)	17 psig (1.22 bar)	2 psig (0.13 bar)	16.5 psig (1.13 bar)
	508 (30 lbs)	6.5 psig (0.44 bar)	32 psig (2.20 bar)	7 psig (0.48 bar)	32 psig (2.20 bar)	6 psig (0.41 bar)	31 psig (2.14 bar)	5 psig (0.34 bar)	30 psig (2.07 bar)	4 psig (0.27 bar)	29 psig (2.00 bar)
2400 SMT PO 3/8" IV	1245 (15 lbs)	4 psig (0.27 bar)	16.5 psig (1.13 bar)	4 psig (0.27 bar)	16 psig (1.10 bar)	3.5 psig (0.23 bar)	16 psig (1.10 bar)	3.5 psig (0.23 bar)	15.5 psig (1.06 bar)	3.5 psig (0.23 bar)	15 psig (1.03 bar)
	538 (20 lbs)	4.5 psig (0.31 bar)	18 psig (1.24 bar)	4 psig (0.27 bar)	18 psig (1.24 bar)	4 psig (0.27 bar)	17 psig (1.22 bar)	4 psig (0.27 bar)	16.5 psig (1.13 bar)	4 psig (0.27 bar)	16.5 psig (1.13 bar)
	508 (30 lbs)	8 psig (0.55 bar)	32 psig (2.20 bar)	8 psig (0.55 bar)	32 psig (2.20 bar)	7.5 psig (0.51 bar)	32 psig (2.20 bar)	7.5 psig (0.51 bar)	31 psig (2.13 bar)	7.5 psig (0.51 bar)	30 psig (2.07 bar)
2400 SMT PO 3/8" IV SNAP	1245 (15 lbs)	4 psig (0.27 bar)	14.5 psig (1.00 bar)	3.5 psig (0.23 bar)	14.5 psig (1.00 bar)	4.5 psig (0.31 bar)	14 psig (0.97 bar)	4.5 psig (0.31 bar)	14 psig (0.97 bar)	4.5 psig (0.31 bar)	13.5 psig (0.93 bar)
	538 (20 lbs)	4 psig (0.27 bar)	17.5 psig (1.20 bar)	4 psig (0.27 bar)	17 psig (1.22 bar)	5 psig (0.34 bar)	17 psig (1.22 bar)	5 psig (0.34 bar)	16.5 psig (1.13 bar)	5 psig (0.34 bar)	16 psig (1.10 bar)
	508 (30 lbs)	7.5 psig (0.51 bar)	32 psig (2.20 bar)	7 psig (0.48 bar)	32 psig (2.20 bar)	8 psig (0.55 bar)	31 psig (2.13 bar)	8.5 psig (0.58 bar)	30 psig (2.07 bar)	8.5 psig (0.58 bar)	29 psig (2.00 bar)
2400 SMT PO 7/16" EP IV	1245 (15 lbs)	4 psig (0.27 bar)	15.5 psig (1.06 bar)	4 psig (0.27 bar)	15.5 psig (1.06 bar)	3.5 psig (0.23 bar)	15 psig (1.03 bar)	3.5 psig (0.23 bar)	14.5 psig (1.00 bar)	3.5 psig (0.23 bar)	14 psig (0.97 bar)
	538 (20 lbs)	4.5 psig (0.31 bar)	18.5 psig (1.31 bar)	4.5 psig (0.31 bar)	18.5 psig (1.27 bar)	4.5 psig (0.31 bar)	17.5 psig (1.20 bar)	4 psig (0.27 bar)	16 psig (1.10 bar)	4 psig (0.27 bar)	15 psig (1.03 bar)
	508 (30 lbs)	8 psig (0.55 bar)	32 psig (2.20 bar)	8 psig (0.55 bar)	31 psig (2.13 bar)	7.5 psig (0.51 bar)	30 psig (2.07 bar)	7.5 psig (0.51 bar)	29 psig (2.00 bar)	7.5 psig (0.51 bar)	28 psig (1.93 bar)
2400 SMT PO 1/2" IV	1245 (15 lbs)	4 psig (0.27 bar)	15 psig (1.03 bar)	4 psig (0.27 bar)	15 psig (1.03 bar)	4.5 psig (0.31 bar)	14.5 psig (1.00 bar)	5 psig (0.34 bar)	13.5 psig (0.93 bar)	5 psig (0.34 bar)	12 psig (0.83 bar)
	538 (20 lbs)	4 psig (0.27 bar)	17 psig (1.22 bar)	3.5 psig (0.23 bar)	16.5 psig (1.13 bar)	4.5 psig (0.31 bar)	16.5 psig (1.13 bar)	4.5 psig (0.31 bar)	15.5 psig (1.06 bar)	5 psig (0.34 bar)	14 psig (0.97 bar)
	508 (30 lbs)	7 psig (0.48 bar)	30 psig (2.07 bar)	7 psig (0.48 bar)	30 psig (2.07 bar)	8 psig (0.58 bar)	30 psig (2.07 bar)	8 psig (0.55 bar)	28 psig (1.93 bar)	8.5 psig (0.58 bar)	27 psig (1.86 bar)
2400 SMT 1/2" IV SNAP	1245 (15 lbs)	3 psig (0.20 bar)	16 psig (1.10 bar)	3 psig (0.20 bar)	15 psig (1.03 bar)	4.5 psig (0.31 bar)	14.5 psig (1.00 bar)	5 psig (0.34 bar)	14 psig (0.97 bar)	5 psig (0.34 bar)	13.5 psig (0.93 bar)
	538 (20 lbs)	3.5 psig (0.23 bar)	17 psig (1.22 bar)	3 psig (0.20 bar)	16.5 psig (1.13 bar)	4.5 psig (0.31 bar)	16 psig (1.10 bar)	5 psig (0.34 bar)	15 psig (1.03 bar)	5 psig (0.34 bar)	14.5 psig (1.00 bar)
	508 (30 lbs)	7 psig (0.48 bar)	32 psig (2.20 bar)	7.5 psig (0.51 bar)	32 psig (2.20 bar)	7.5 psig (0.51 bar)	31 psig (2.14 bar)	7.5 psig (0.51 bar)	30 psig (2.07 bar)	8 psig (0.55 bar)	29 psig (2.00 bar)
2400 SMT PO 5/8" EP IV	1245 (15 lbs)	4 psig (0.27 bar)	16 psig (1.10 bar)	4 psig (0.27 bar)	16 psig (1.10 bar)	6 psig (0.41 bar)	16.5 psig (1.13 bar)	7.5 psig (0.51 bar)	16 psig (1.10 bar)	8.5 psig (0.58 bar)	15.5 psig (1.06 bar)
	538 (20 lbs)	4 psig (0.27 bar)	19 psig (1.31 bar)	4 psig (0.27 bar)	19 psig (1.31 bar)	6.5 psig (0.44 bar)	18.5 psig (1.27 bar)	7.5 psig (0.51 bar)	17.5 psig (1.20 bar)	9 psig (0.62 bar)	17 psig (1.22 bar)
	508 (30 lbs)	8 psig (0.55 bar)	32 psig (2.20 bar)	8.5 psig (0.58 bar)	32 psig (2.20 bar)	10 psig (0.68 bar)	31 psig (2.14 bar)	11.5 psig (0.79 bar)	30 psig (2.06 bar)	12.5 psig (1.48 bar)	29 psig (2.00 bar)

2400 SMT PO 3/4" IV	1245 (15 lbs)	5 psig (0.34 bar)	17 psig (1.72 bar)	5 psig (0.34 bar)	17 psig (1.72 bar)	7.5 psig (0.51 bar)	14.5 psig (1.00 bar)	8.5 psig (0.58 bar)	13 psig (0.89 bar)	10 psig (0.68 bar)	12 psig (0.83 bar)
	538 (20 lbs)	5.5 psig (0.37 bar)	19 psig (1.31 bar)	5.5 psig (0.37 bar)	19 psig (1.31 bar)	7 psig (0.48 bar)	17 psig (1.72 bar)	9 psig (0.62 bar)	16 psig (1.10 bar)	11 psig (0.75 bar)	14 psig (0.97 bar)
	508 (30 lbs)	9 psig (0.62 bar)	34 psig (2.34 bar)	9 psig (0.62 bar)	34 psig (2.34 bar)	11 psig (0.75 bar)	33 psig (2.27 bar)	13 psig (0.89 bar)	32 psig (2.20 bar)	15 psig (1.03 bar)	30 psig (2.07 bar)
2400 SMT PO 3/4" IV SNAP	1245 (15 lbs)	4 psig (0.27 bar)	15 psig (1.03 bar)	4 psig (0.27 bar)	15 psig (1.03 bar)	6.5 psig (0.44 bar)	14.5 psig (0.96 bar)	8 psig (0.55 bar)	13.5 psig (0.93 bar)	9 psig (0.62 bar)	12 psig (0.83 bar)
	538 (20 lbs)	5 psig (0.34 bar)	18.5 psig (1.27 bar)	5 psig (0.34 bar)	18.5 psig (1.27 bar)	6.5 psig (0.44 bar)	16.5 psig (1.13 bar)	8 psig (0.55 bar)	15.5 psig (1.06 bar)	9.5 psig (0.66 bar)	14 psig (0.97 bar)
	508 (30 lbs)	9 psig (0.62 bar)	32 psig (2.20 bar)	9 psig (0.62 bar)	32 psig (2.20 bar)	10 psig (0.68 bar)	31 psig (2.14 bar)	11 psig (0.75 bar)	30 psig (2.07 bar)	12.5 psig (0.86 bar)	29 psig (2.00 bar)
2400 SMT PO 7/8" EP IV	1245 (15 lbs)	3.5 psig (0.23 bar)	15 psig (1.03 bar)	4 psig (0.27 bar)	15 psig (1.03 bar)	7 psig (0.48 bar)	14.5 psig (1.00 bar)	11 psig (0.75 bar)	14 psig (0.97 bar)	13.5 psig (0.93 bar)	13.5 psig (0.93 bar)
	538 (20 lbs)	3.5 psig (0.23 bar)	17.5 psig (1.20 bar)	4 psig (0.27 bar)	17.5 psig (1.20 bar)	7.5 psig (0.51 bar)	17 psig (1.72 bar)	10.5 psig (0.72 bar)	16.5 psig (1.13 bar)	13.5 psig (0.93 bar)	16 psig (1.10 bar)
	508 (30 lbs)	7 psig (0.48 bar)	30 psig (2.07 bar)	7.5 psig (0.51 bar)	30 psig (2.07 bar)	10.5 psig (0.72 bar)	29 psig (2.00 bar)	14 psig (0.97 bar)	28 psig (1.93 bar)	17 psig (1.72 bar)	27 psig (1.86 bar)
2400 SMT PO 1" IV	1245 (15 lbs)	4.5 psig (0.31 bar)	14.5 psig (1.00 bar)	5 psig (0.34 bar)	14 psig (0.97 bar)	8.5 psig (0.58 bar)	13 psig (0.89 bar)	12.5 psig (0.86 bar)	11.5 psig (0.79 bar)	16 psig (1.10 bar)	11 psig (0.75 bar)
	538 (20 lbs)	4.5 psig (0.31 bar)	17 psig (1.72 bar)	5 psig (0.34 bar)	17 psig (1.72 bar)	8.5 psig (0.58 bar)	16 psig (1.10 bar)	12.5 psig (0.86 bar)	15 psig (1.03 bar)	17 psig (1.72 bar)	14 psig (0.97 bar)
	508 (30 lbs)	7 psig (0.48 bar)	31 psig (2.14 bar)	7.5 psig (0.51 bar)	31 psig (2.14 bar)	12 psig (0.83 bar)	30 psig (2.07 bar)	16 psig (1.10 bar)	29 psig (2.00 bar)	19.5 psig (1.34 bar)	28 psig (1.93 bar)
2400 SMT PO 1" IV SNAP	1245 (15 lbs)	4.5 psig (0.31 bar)	16.5 psig (1.13 bar)	4.5 psig (0.31 bar)	16.5 psig (1.13 bar)	8.5 psig (0.58 bar)	15.5 psig (1.06 bar)	11.5 psig (0.79 bar)	15 psig (1.03 bar)	15 psig (1.03 bar)	15 psig (1.03 bar)
	538 (20 lbs)	4.5 psig (0.31 bar)	19 psig (1.31 bar)	4.5 psig (0.31 bar)	19 psig (1.31 bar)	8.5 psig (0.58 bar)	16 psig (1.10 bar)	11.5 psig (0.79 bar)	15.5 psig (1.06 bar)	15 psig (1.03 bar)	15 psig (1.03 bar)
	508 (30 lbs)	8 psig (0.55 bar)	32 psig (2.20 bar)	8 psig (0.55 bar)	32 psig (2.20 bar)	12 psig (0.83 bar)	31 psig (2.14 bar)	16 psig (1.10 bar)	30 psig (2.07 bar)	19.5 psig (1.34 bar)	29 psig (2.00 bar)

Table 8 - 2", 3", 4", 6", 8" & 10" Cage Guided HPCV											
Valve Description	ΔP	0 psig (0 bar)		100 psig (6.8 bar)		500 psig (34.4 bar)		1000 psig (68.9 bar)		1500 psig (103.4 bar)	
	Spring	Crack	Full	Crack	Full	Crack	Full	Crack	Full	Crack	Full
2150 SMT PB 2 IN IV	15 lbs	3 psig (0.21bar)	16 psig (1.1bar)	3.5 psig (0.24bar)	16 psig (1.1bar)	5.5 psig (0.38bar)	15 psig (1.03bar)	7.5 psig (0.52bar)	14 psig (0.97bar)	9.5 psig (0.66bar)	12 psig (0.83bar)
	20 lbs	3 psig (0.21bar)	19 psig (1.31bar)	3 psig (0.21bar)	18 psig (1.24bar)	5.5 psig (0.38bar)	17 psig (1.17bar)	8 psig (0.55bar)	16 psig (1.1bar)	8.5 psig (0.59bar)	15 psig (1.03bar)
	30 lbs	6 psig (0.41bar)	32 psig (2.21bar)	7 psig (0.48bar)	31 psig (2.14bar)	8 psig (0.55bar)	30 psig (2.07bar)	10.5 psig (0.72bar)	29 psig (2bar)	12.5 psig (0.86bar)	28 psig (1.93bar)
3150 FMT PB 3" IV	30 lbs	6 psig (0.41bar)	30 psig (2.07bar)	6.5 psig (0.45bar)	27.5 psig (1.9bar)	10.5 psig (0.72bar)	27 psig (1.86bar)	13.5 psig (0.93bar)	25 psig (1.72bar)	17 psig (1.17bar)	22 psig (1.52bar)
3150 FMT PB 3" IV- PC	30 lbs	Shut	27 psig (1.86bar)	Shut	28 psig (1.93bar)	Shut	30.5 psig (2.1bar)	Shut	33 psig (2.28bar)	Shut	36.5 psig (2.52bar)
4150 FMT PB	30 lbs	8.5 psig (0.59bar)	32 psig (2.21bar)	8.5 psig (0.59bar)	32 psig (2.21bar)	8 psig (0.55bar)	29.5 psig (2.03bar)	7.5 psig (0.52bar)	27 psig (1.86bar)	6 psig (0.41bar)	24.5 psig (1.69bar)
4150 FMT PB 4 IN IV PC	30 lbs	Shut	31 psig (2.14bar)	Shut	32.5 psig (2.24bar)	Shut	34.5 psig (2.38bar)	Shut	37 psig (2.55bar)	Shut	39.5 psig (2.72bar)
6150 FMT PB 6 IN IV	30 lbs	8 psig (0.55bar)	29 psig (2bar)	9.5 psig (0.66bar)	28 psig (1.93bar)	10.5 psig (0.72bar)	27 psig (1.86bar)	11 psig (0.76bar)	25 psig (1.72bar)	11.5 psig (0.79bar)	22 psig (1.52bar)
8150 FMT PB 8 IN IV	30 lbs	8 psig (0.55bar)	29 psig (2bar)	8.5 psig (0.59bar)	27.5 psig (1.9bar)	10 psig (0.69bar)	26.5 psig (1.83bar)	10.5 psig (0.72bar)	24 psig (1.65bar)	10.5 psig (0.72bar)	21.5 psig (1.48bar)
10150 FMT PB 8 IN IV	30 lbs	7.5 psig (0.52bar)	28.5 psig (1.97bar)	8.5 psig (0.59bar)	27.5 psig (1.9bar)	9.5 psig (0.66bar)	26 psig (1.79bar)	10 psig (0.69bar)	24 psig (1.65bar)	10.5 psig (0.72bar)	21.5 psig (1.48bar)

NOTES:



Kimray is an ISO 9001- certified manufacturer.