

DUMP VALVES

WEIGHT OPERATED



‡®

KIMRAY
INC.®

‡ Configuration of Water Valve is a trademark of Kimray, Inc..

NOTE: We reserve the right to modify or change, without prior notice, any statement or information contained herein.
© Copyright 2020, Kimray, Inc.



TREATER VALVE: **·05:10.1 - 05:10.3**
APPLICATIONS: As oil or water valve for emulsion treaters, water knockouts and
free water knockouts. Can be used for pressure, atmospheric, or vacuum operation.
Ideal for discharging salt water to disposal systems.
OPERATING PRESSURE RANGES: 0 psig to 125 psig

REMOVABLE HARD SEAT: **·05:10.4**

DIAPHRAGM BALANCED TRUNNION: **·05:20.1**
APPLICATIONS: Regulation of inlet pressure to gas compressors. Control of supply or distribution
systems pressures.
OPERATING PRESSURE RANGES: 0 psig to 125 psig

FLOW COEFFICIENT **·05:I**
DIMENSIONS· **·05:II**
SEALS· **·05:III**
MATERIAL SPECIFICATIONS **·05:IV**

WEIGHT OPERATED DUMP VALVES



CODE BUILDER W SERIES

Series:

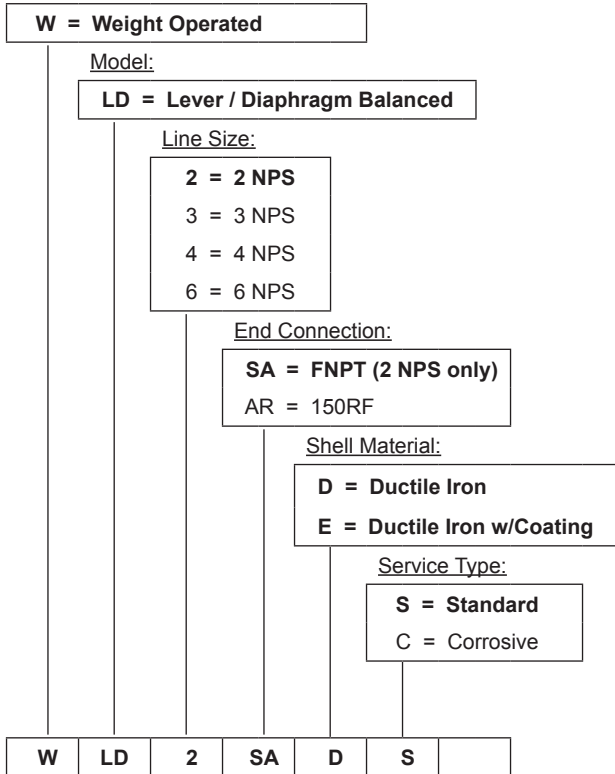

Options: Additional cost and lead times will apply
If multiple options required input in sequential order
Leave blank if no options required

- 1 = NACE Certification (Corrosive Option Only)
- 2 = Hydrostatic Test Certification
- 3 = MTR (Shell Components)
- H = HSN Elastomers
- V = FKM Elastomers
- X = Export (Hydrostatic test, MTR & 3.1)

Not all selections available on all products listed.
See product pages 05:10.1 - 05:10.3 for available options

APPLICATIONS:





As oil or water valve for emulsion treaters, water knockouts and free water knockouts. Can be used for pressure, atmospheric, or vacuum operation. Ideal for discharging salt water to disposal systems.

FEATURES:

- Single soft seat for tight shut off
- Balanced against upstream pressure
- Balanced against downstream pressure or vacuum
- Standard weight and lever holds approx. 4' liquid head
- Weights may be added to increase liquid head
- Can be manually opened and closed
- Sample tap on inlet connection
- Rotary stuffing box with leakless, low friction TEFLON packing
- All interior parts can be removed without taking valve out of line
- Prevents air from entering salt water disposal system piping

CERTIFICATIONS:

Canadian Registration Number (CRN):
 0C15735.24567890NTY (Ductile)
 0C15811.24567890NTY (Steel)
 Kimray is an ISO 9001- certified manufacturer.

-  Diaphragm Assembly
-  Vessel Gas Pressured
-  Downstream Pressure or Vacuum
-  Gas Pressure plus Liquid Head

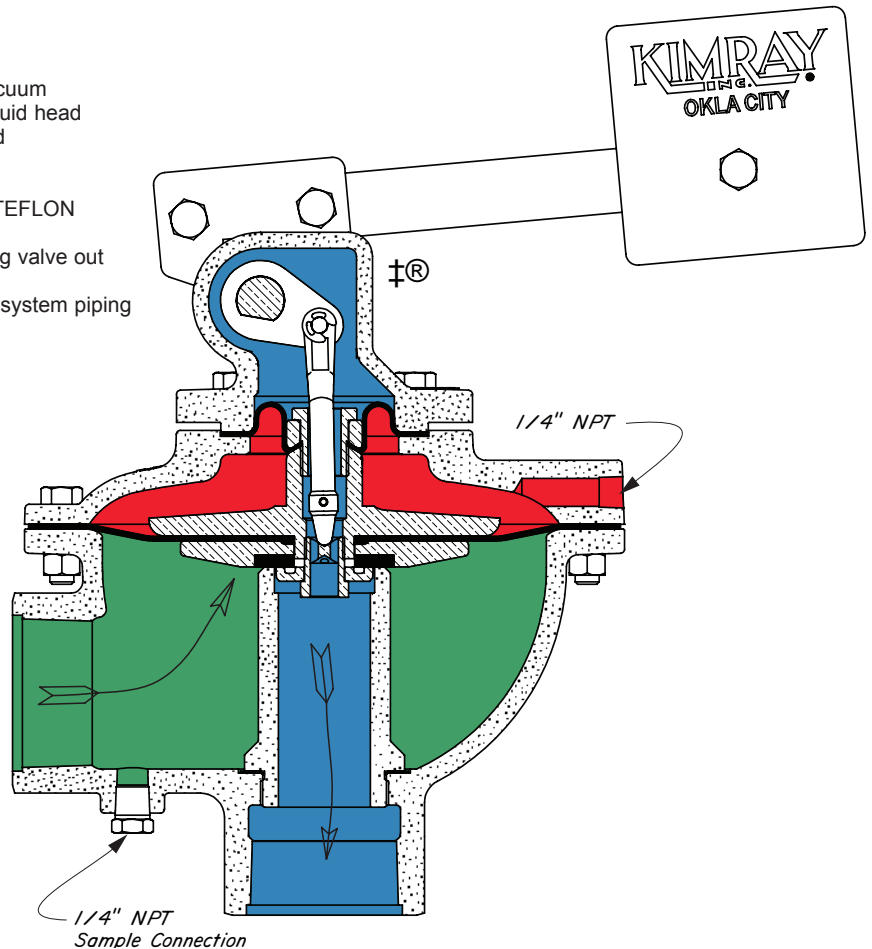

Standard Configuration Code †	Order Code	Line Size	Connection Type	Body Type	Max Δ P psig	Max. W.P. psig ††	Cv	Cf
WLD2SADS	DAA	2"	NPT	Angle	125	125	36.5	0.75
WLD2ARDS	DAB						36.5	
WLD3ARDS	DAC	3"	93.3					
WLD4ARDS	DAD	4"	173					
WLD6ARDS	DAE	6"	371					
					60			

NOTES:

For standard & optional seals, metals, Cf Cv values, material specifications & dimensions see technical data on pages 05:1 - 05:1V
 † For Corrosive service remove last "S" & replace with "C"
 † For KimCoat option remove last "S" & replace with "K"
 † For code builder see page 05:00.2
 †† Max W.P. values based on -20°F to 100°F.

WEIGHT OPERATED DUMP VALVES

TREATER / DUMP VALVE
MODEL LD PARTS DRAWING

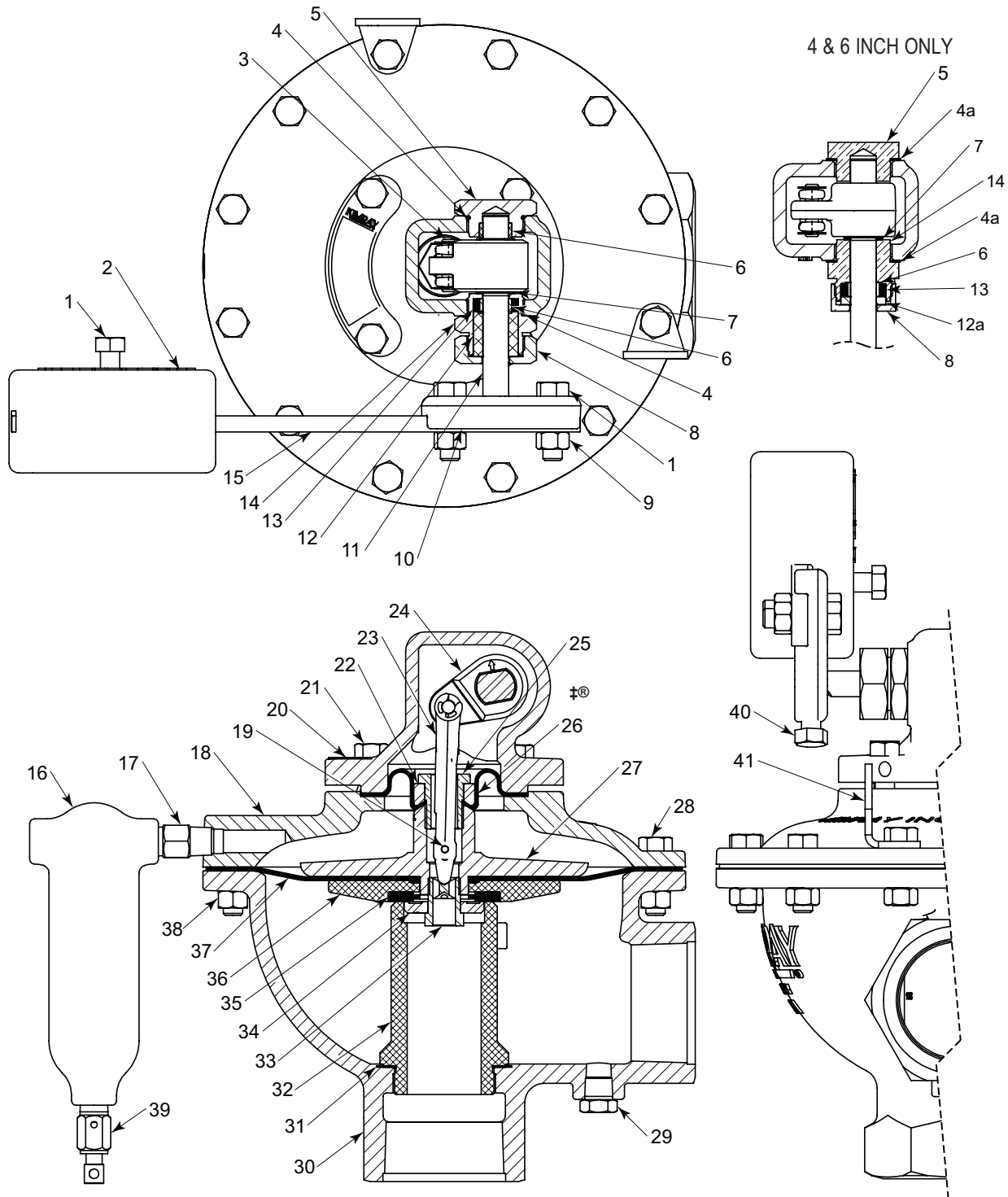

All Pictures shown are for illustration purpose only. Actual product may vary due to product enhancement.
‡ Configuration of Water Valve is a trademark of Kimray, Inc.
www.kimray.com



WEIGHT OPERATED DUMP VALVES

**TREATER / DUMP VALVE
MODEL LD PARTS LIST**

ITEM	QTY.	DESCRIPTION	PART NO.									
			STANDARD				CORROSIVE					
			2 INCH	3 INCH	4 INCH	6 INCH	2 INCH	3 INCH	4 INCH	6 INCH		
1		Bolt	247 (3)		247 (4)		247 (3)		247 (4)			
2	(QTY)	Weight	7 lbs.	424 (1)	----		424 (1)	----	426 (1)	426 (2)		
			9 lbs.	----	425 (1)	----		----	425 (1)	----		
			11 lbs.	----		426 (1)	426 (2)	----		426 (1)	426 (2)	
3	1	Link Pin w/ Snap Ring * (kit includes Snap Rings only)	316	317		1790		316SS6	317SS6	1790SS6		
4	2	O-Ring ◇ *	2131HSN	5226HSN	----		2131HSN		5226HSN	----		
4a	2	Gasket *	----		366	1789		----		366	1789	
5	1	Trunnion Plug	7522	7523	369	1777		7522S6	7523S6	369	1777	
6	(QTY)	Teflon ring ◇ *	7662 (2)	355 (2)	356 (1)	1786 (1)		7662 (2)	355 (2)	356 (1)	1786 (1)	
7	1	Thrust Washer ◇ *	360	361	362	1788		360	361	362	1788	
8	1	Stuffing Box Nut ◇	7917	7919	347	1778		7917	7919	347SS6	1778SS6	
9	2	Nut	241				241					
10	1	Lever Hub	7600	7601	7602	7603		7600	7601	7602	7603	
11	1	Shaft	Old Style	7404	7408	7427	7449		7404S6	7408S6	7427S6	7449S6
			New Style	7609	7610	7611	7612		7609S6	7610S6	7611S6	7612S6
12	1	Bushing ◇ *	7915	7916	----		7915		7916	----		
12a	1	Follower	----	----	350	1785		----	----	350	1785	
13	(QTY)	Packing Ring ◇ *	351 (1)	352 (1)	353 (1)	1787 (2)		351 (1)	352 (1)	353 (1)	1787 (2)	
14	1	Stuffing Box ◇	7918	7920	359	1779		7918S6	7920S6	359SS6	1779SS6	
15	1	Lever Bar	Standard 11"	419	----		419		----			
			Optional 19"	419L	----		419L		----			
			Standard 16"	----	420		----		420			
			Optional 29"	----	420L		----		420L			
16	1	Drip Pot	431				431					
17	1	Nipple	648				648SS6					
18	1	Housing	1499	411	412	1768		1499‡	411‡	412‡	1768‡	
19	1	Dowel Pin	932	428	429SS6	1792SS6		932SS6	1470BSS6	429SS6	1792SS6	
20	1	Bonnet	295	296	297	1767		295‡	296‡	297‡	1767‡	
21	(QTY)	Bolt	380 (4)	247 (6)	247 (8)	1794 (8)		380 (4)	247 (6)	247 (8)	1794 (8)	
22	1	Diaphragm Retainer	401SS6	402SS6	403SS6	1782		401SS6	402SS6	403SS6	1782	
23	1	Stem	398	399	400	1774		398SS6	399SS6	400SS6	1774SS6	
24	1	Trunnion Hub	Old Style	7403	7407	7454	7453		7403S6	7407S6	7454S6	7453S6
			New Style	7613S6	7614S6	7615S6	7616S6		7613S6	7614S6	7615S6	7616S6
25	1	Diaphragm Bolt	407	408	409	1780		407SS6	408SS6	409SS6	1780SS6	
26	1	Diaphragm *	416	417	418	1766		416	417	418	1766	
27	1	Diaphragm Plate	404	405	406	1769		404‡	405‡	406‡	1769‡	
28	(QTY)	Bolt	247 (12)	430 (14)	430 (16)	1795 (24)		247 (12)	430 (14)	430 (16)	1795 (24)	
29	1	Plug	699				699SS6					
30	1	NPT Thru 150RF Angle	381	----	----	----		381‡	----	----	----	
			1492	382	383	1765		1492‡	382‡	383‡	1765‡	
31	1	Gasket *	387	388	389	1797		387	388	389	1797	
32	1	Seat	384DEL	385DEL	386	1771		384DEL	385DEL	386	1771	
33	1	Pivot Bolt	396		397	1781		396SS6		397SS6	1781SS6	
34	1	Ratio Plug	413SS6	414SS6	415SS6	1773		413SS6	414SS6	415SS6	1773SS6	
35	1	Seat *	7502HSN	7503HSN	392	1793P		7502HSN	7503HSN	392	1793	
36	1	Seat Disc	393KC	394KC	395	1770		393KC	394KC	395	1770	
37	1	Diaphragm *	421	422	423	1764		421	422	423	1764	
38	(QTY)	Nut	241 (12)	241 (14)	241 (16)	101 (24)		241 (12)	241 (14)	241 (16)	101 (24)	
39	1	Bleed Valve	YBF1				YBF1-SS6					
40	1	Set Screw	7608				7608					
41	2	Lifting Rings	7559		----		7559		----			

‡ Coated Parts available with "E" shell material

Repair Kits

REL REM REN REP REL REM REN REP

* These parts are recommended spare parts and are stocked as repair kits.

Stuffing Box Replacement Kits

RZL RZM ---- RZL RZM ----

◇ These parts are stocked as Stuffing Box Replacement Kits.

WEIGHT OPERATED DUMP VALVES

REMOVABLE HARD SEAT ASSEMBLY

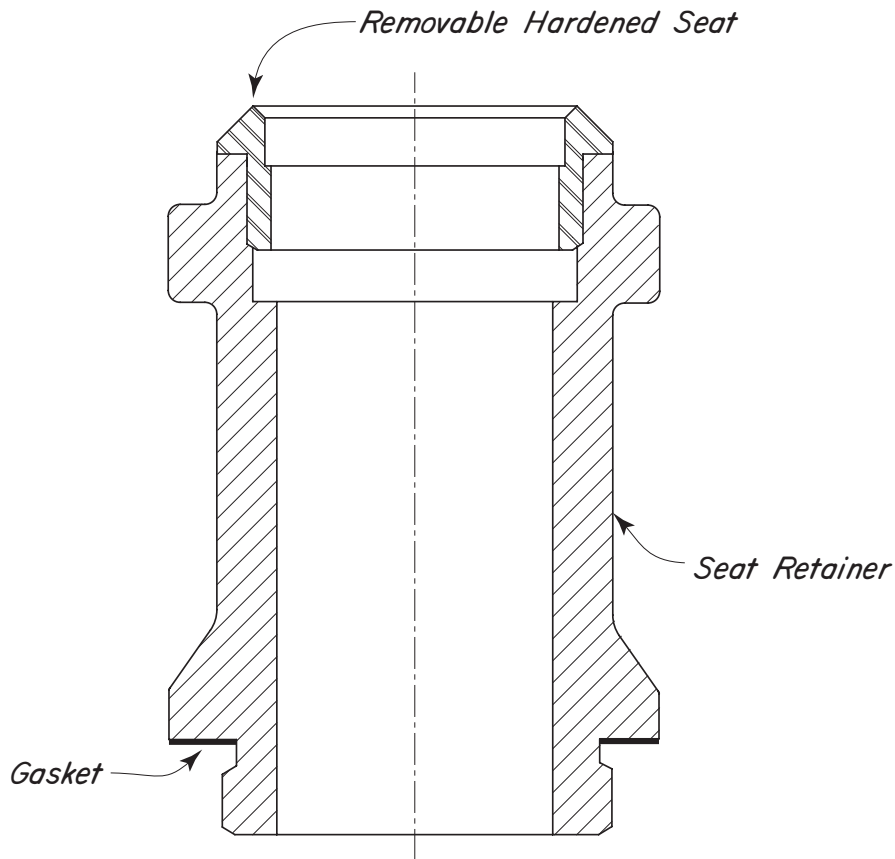

SEATS AVAILABLE:

CODE	LINE SIZE	SEAT	SEAT MATERIAL	RETAINER	GASKET
384H	2"	384HA	17-4	384HB	387
385H	3"	385PH	17-4	385HB	388
	3"	385ASS6	316 SS	385HB	388

All Pictures shown are for illustration purpose only. Actual product may vary due to product enhancement.

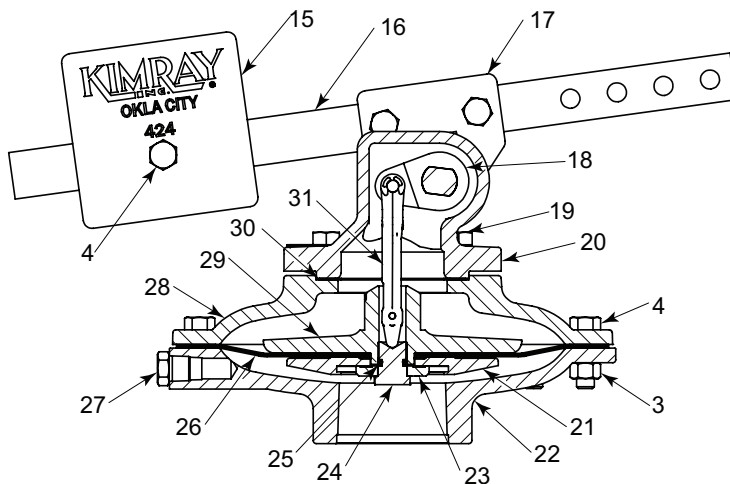
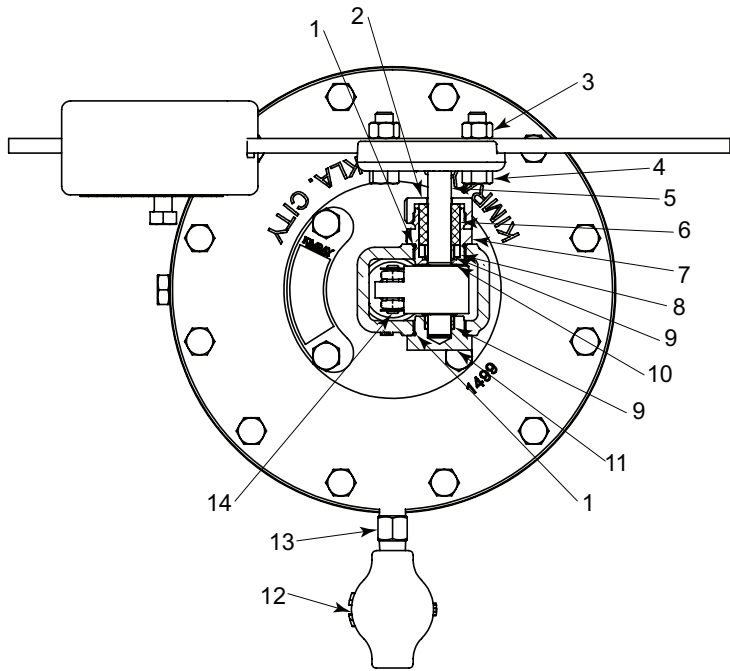

ITEM	QTY.	DESCRIPTION	PART NO.	
			DMA	DMAS6
1	2	O-Ring *	2131HSN	
2	1	Stuffing Box Nut	7917	
3	14	Nut	241	
4	15	Bolt	247	
5	1	Shaft	7609	7609S6
6	1	Bushing *	7915	
7	1	Stuffing Box	7918	7918S6
8	1	Packing Ring *	351	
9	1	Packing *	7662	
10	1	Thrust Washer *	360	
11	1	Trunnion Plug	7522	7522S6
12	1	Drip Pot	YAM	YAMSS6
13	1	Nipple	648SS6	648SS6
14	1	Link Pin w/ Snap Ring * (kit includes Snap Rings only)	316	316SS6
15	1	Weight	424	
16	1	Lever	749	
17	1	Lever Hub	7600	
	1	Set Screw (Not Shown)	7608	
18	1	Trunnion Hub	7613S6	
19	4	Bolt	380	
20	1	Bonnet	295	
21	1	Seat Retaining Disc	393KC	393SS6
22	1	Lower Housing	714	
23	1	Ratio Plug	413SS6	
24	1	Pivot Bolt	747	747SS6
25	1	O-Ring *	530	
26	1	Diaphragm *	421	
27	1	Plug	699	699SS6
28	1	Upper Housing	1499	
29	1	Diaphragm Plate	746	
30	1	Gasket *	750	
31	1	Stem	398	398SS6
Repair Kits			REW	

*These parts are recommended spare parts and are stocked as repair kits.

Standard Order Code	Description	Line Size	Connection Type	Oper. Press. psig	Max. W.P. psig ††
DMA	26 DMV	2"	NPT	0-125	125
DMAS6	26 DMV	2"	NPT	0-125	125

NOTES:

For standard & optional seals, metals, Cf Cv values, material specifications & dimensions see technical data on pages 05:1 - 05:1V

†† Max W.P. values based on -20°F to 100°F.

All Pictures shown are for illustration purpose only. Actual product may vary due to product enhancement.

WEIGHT OPERATED DUMP VALVES



DIAPHRAGM BALANCED TRUNNION TYPICAL INSTALL

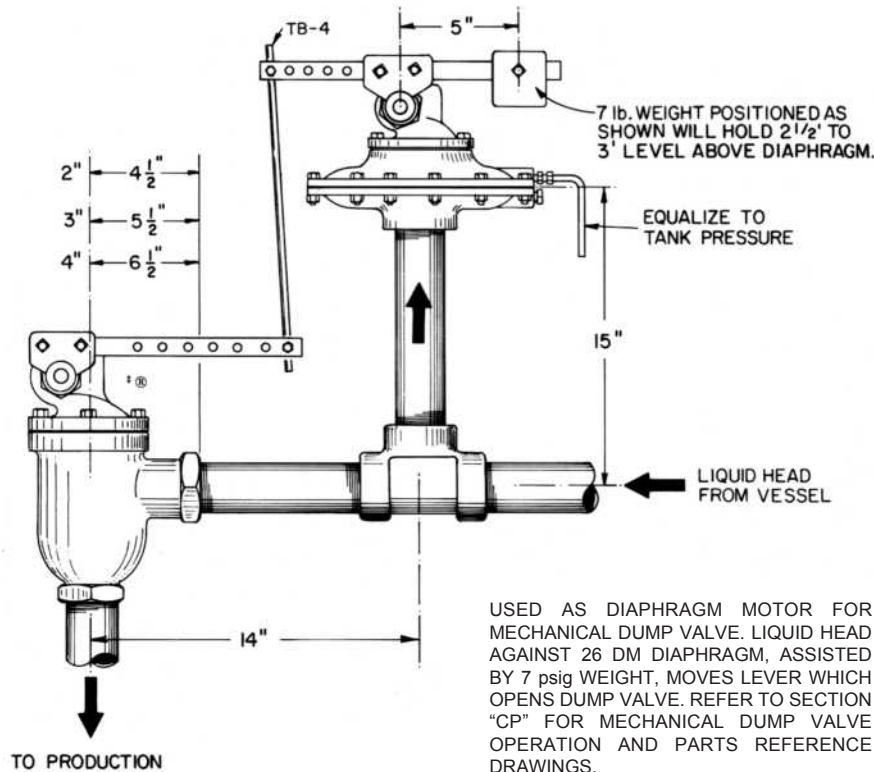
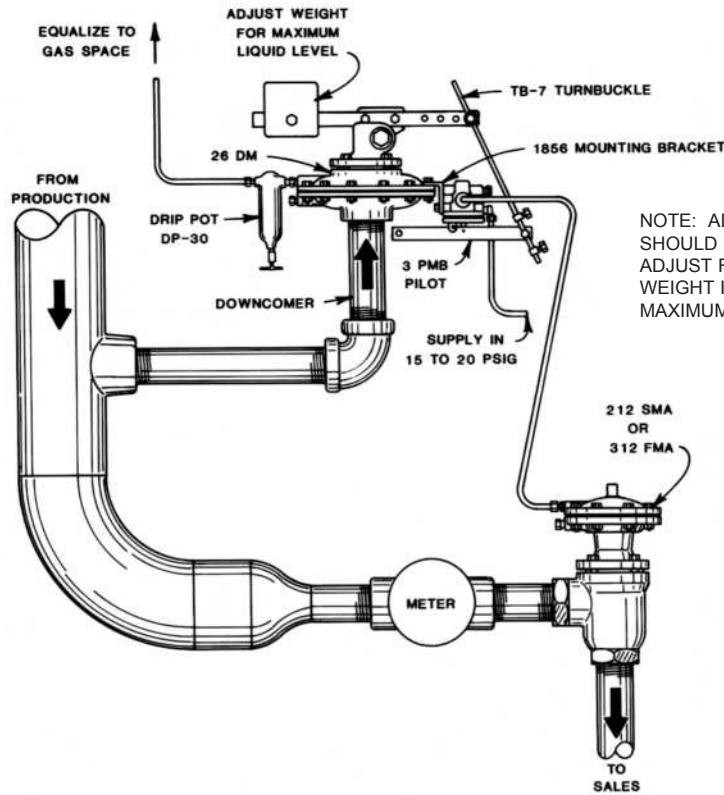

All Pictures shown are for illustration purpose only. Actual product may vary due to product enhancement.

Table 1 - Flow Coefficient(Cv) Weight Operated Dump Valve													
Line Size	Trim Size in. (mm)	Trim Type	Cf	Valve Opening Percentage									
				10	20	30	40	50	60	70	80	90	100
2"	2 in (50 mm)	Linear (Nominal)	0.75	0.6	0.9	4.2	8.9	13.8	18.4	23.4	28.3	33.0	36.5
3"	3 in (76 mm)		0.75	0.7	11.5	21.1	29.1	37.8	48.1	60.0	72.6	84.2	93.3
4"	4 in (100 mm)		0.75	1.4	18.6	38.4	56.6	76.9	98.8	120.5	142.2	159.9	173.5
6"	6 in (152 mm)		0.75	1.5	32.6	68.1	103.8	146.4	195.0	247.0	294.0	337.2	371.9

Kimray flow equations conform to ANSI/ISA - 75.01.01-2002
 Kimray inherent flow characteristics conform to ANSI/ISA 75.11.01 -1985

WEIGHT OPERATED DUMP VALVES



DIMENSIONS
MODEL LD

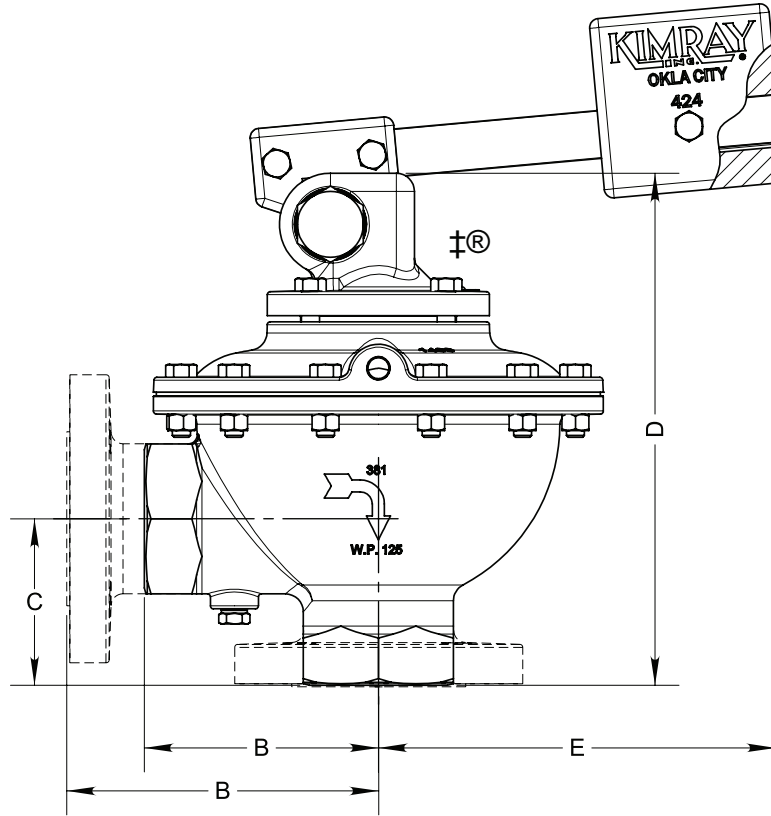

Table 2 - Dimensions

	End Connection	A	B	C	D	E	Approx. Weight
2"	NPT	9 3/8 in. (238 mm)	4 7/8 in. (123 mm)	3 1/2 in. (88 mm)	10 5/8 in. (269 mm)	8 1/2 in. (215 mm)	46 lbs (20.8 kg)
	150RF	9 3/8 in. (238 mm)	6 1/2 in. (165 mm)	3 1/2 in. (88 mm)	10 5/8 in. (269 mm)	8 1/2 in. (215 mm)	
	150RF	11 3/4 in. (298 mm)	8.00 in. (203 mm)	4 1/4 in. (107 mm)	13 1/2 in. (342 mm)	13.00 in. (330 mm)	90 lbs (40.8 kg)
	150RF	13.00 in. (330 mm)	9.00 in. (228 mm)	4 3/4 in. (120 mm)	14 5/8 in. (371 mm)	13.00 in. (330 mm)	132 lbs (59.8 kg)
	150RF	18 5/8 in. (473 mm)	12 1/4 in. (311 mm)	6 3/4 in. (95 mm)	21 1/2 in. (317 mm)	12 1/2 in. (317 mm)	375 lbs (170 kg)

All Pictures shown are for illustration purpose only. Actual product may vary due to product enhancement.
‡ Configuration of Water Valve is a trademark of Kimray, Inc.
www.kimray.com

Table 3 - Seal Options

Part	Standard Material	Optional Material
Diaphragm	Nitrile	FKM
Soft Seat	HSN	FKM
O-Ring	HSN	FKM

Table 4 - Seal Specifications

		NITRILE	HIGHLY SATURATED NITRILE	FKM
Kimray Suffix		-	HSN	V
Resistance	Abrasion	G	G-E	G
	Acid	F	G-E	G-E
	Chemical	F	F	E
	Cold	G	G	P
	Flame	P	P	E
	Heat	G	E	E
	Oil	G-E	E	E
	Ozone	P	G	G-E
	Set	G	G	G-E
	Tear	F	F	F
	Water/Steam	F	E	P
	Weather	F	G	E
	CO2	F-G	G	G
	H2S	P	F	P
	Methanol	F	E	P
Properties	Dynamic	G	G	G
	Electrical	F	F	F
	Impermeability	G	G	G
	Tensile Strength	G	G-E	G
Temp. Range		-20° to +250°F	-20° to +300°F	-15° to +400°F
		-29° to +121°C	-29° to +149°C	-26° to +204°C
RATINGS: P-POOR, F-FAIR, G-GOOD, E-EXCELLENT				

Table 5 - Materials Options		
Part Description	Standard Material	Corrosive Material
Body	Ductile (ASTM A395)	WCB (ASTM A216) + Kimcoat
Bonnet	Ductile (ASTM A395)	WCB (ASTM A216) + Kimcoat
Housing	Ductile (ASTM A395)	WCB (ASTM A216) + Kimcoat
Removable Seat	2" & 3"	Delrin (ASTM D4181)
	4" & 6"	Ductile (ASTM A395)
Packing Box	Brass B-16 C-36000 HO2	316SS (ASTM A479)

Kimray valves conform to ASME B16.34-2009 for working pressure vs working temperature & ASME B16.5-1996 for flanges and flanged fittings.